

BY2-20

Installation and Initial Settings

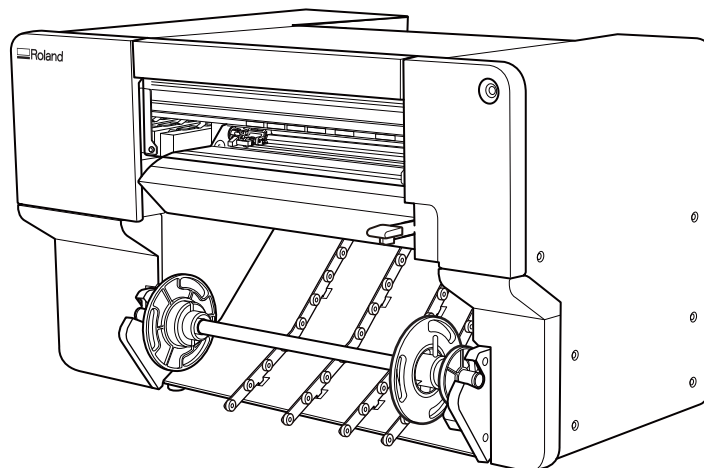

Thank you very much for purchasing this product.

- To ensure correct and safe usage with a full understanding of this product's performance, please be sure to read through this manual completely.
- Unauthorized copying or transferal, in whole or in part, of this manual is prohibited.
- The specifications of this product and the contents of this operation manual are subject to change without notice.
- The operation manual and the product have been prepared and tested as much as possible. If you find any misprints or errors, please inform us.
- Roland DG Corporation assumes no responsibility for any direct or indirect loss or damage that may occur through use of this product, regardless of any failure to perform on the part of this product.
- Roland DG Corporation assumes no responsibility for any direct or indirect loss or damage that may occur with respect to any article made using this product.

Copyright © 2026 Roland DG Corporation

<https://www.rolanddg.com/>

R1-260624

Roland DG Corporation

Contents

| | |
|--|----|
| Introduction | 2 |
| About the Documentation for This Machine | 3 |
| System Requirements/Overview | 4 |
| System Requirements | 4 |
| Software to Be Used | 5 |
| Network Configuration Example | 6 |
| Network Settings | 7 |
| Configuring the Computer's Network Settings | 7 |
| Installing the Software | 10 |
| Software Setup | 11 |
| Step 1: Creating a Roland DG Connect Account | 11 |
| Step 2: Installing Roland DG Connect Hub | 12 |
| Step 3: Signing in to Roland DG Connect Hub | 13 |
| Step 4: Registering the Machine to Roland DG Connect Hub | 14 |
| Step 5: Installing VersaWorks from Roland DG Connect Hub | 15 |
| Step 6: Configuring VersaWorks Settings | 16 |
| Actions to Take When Machine Information Is Not Displayed in Roland DG Connect Hub | 18 |
| Directly Connecting to the Computer | 18 |
| Initial Printer Settings | 23 |
| Media | 24 |
| Loading the Roll Media on the Printer | 25 |
| Installing the Cutting Tool | 29 |
| Step 1: Assemble the Cutting Tool | 29 |
| Step 2: Installing the Cutting Tool | 30 |
| Step 3: Adjusting the Amount of Blade Extension | 31 |
| Ink Filling and Initial Adjustment | 32 |
| Step 1: Filling the Machine with Ink | 32 |
| Step 2: Media Setup | 35 |
| Step 3: Performing a Nozzle Drop-Out Test | 44 |
| Step 4: Performing Automatic Correction | 45 |
| Step 5: Performing Blade Adjustment | 46 |

Introduction

| | |
|---|---|
| About the Documentation for This Machine | 3 |
| System Requirements/Overview | 4 |
| System Requirements..... | 4 |
| Software to Be Used | 5 |
| Network Configuration Example | 6 |
| Network Settings | 7 |
| Configuring the Computer's Network Settings | 7 |

About the Documentation for This Machine

The following instruction manuals are included to ensure proper use of the machine.

- **Safety Precautions**
This manual contains important precautions for using the machine.
- **Quick Access Guide**
This guide contains the setup flow for this machine as well as links to procedures.
- **Regular Maintenance Guidelines**
These guidelines include links to maintenance items listed in the manual. Scan the QR code to open the maintenance instructions directly.
- **Machine Installation**
This guide contains details on how to install the machine.
- **Installing the Software and Configuring Its Initial Settings**
This guide contains information on how to configure the initial settings of the machine.
- **User's Manual**
This manual contains details such as how to use and maintain the machine as well as an FAQ (a set of frequently asked questions).
- **Roland DG Connect Designer User's Manual**
This guide contains basic operating instructions for the design and output software.
- **Videos**
These are the support videos for the manuals. The videos help guide users through explanations that are not easily understood through text and illustrations only.

MEMO

View the manuals and videos from the following URL.

<https://downloadcenter.rolanddg.com/BY2-20>

The illustrations and Utility screens in the manual are for the BN2-20 and the BY-20, so long as the operations and procedures are not affected, while Windows screens are used for Utility.

System Requirements/Overview

System Requirements

Prepare a computer that matches the requirements.

| | Windows | Mac |
|------------------------|---|-------------------------------|
| Operating system (OS) | Windows 11 | macOS 26, 15, 14 |
| CPU | Intel Core i5 4670 or higher | Apple Silicon |
| Memory | 16 GB or more | 8 GB or more |
| Video card and monitor | Full HD (1,920 × 1,080 pixels, 24-bit color) | 1,280 × 1,024 pixels or above |
| Solid state drive | 256 GB or more free space | 128 GB or more |
| Hard disk | 500 GB or more free space | |
| Others | Internet connectivity, web browser, and Ethernet port | |

Software to Be Used

The software to be used is listed below.

In this manual, Roland DG Connect Hub is referred to as "Connect Hub," Roland DG Connect Designer as "Designer," VersaWorks 7 as "VersaWorks," and BY2 Utility as "Utility."

| | | |
|---|--------------|---|
| ① | Connect Hub | System hub software. The major functions are shown below. <ul style="list-style-type: none"> Starting Designer, VersaWorks, and Utility Transferring data between Designer and VersaWorks Transferring printer status and operating information required for the Roland DG Connect service |
| ② | Designer | Design software used on Roland DG Connect. The software makes it easy to create print data, set print settings such as media and quality, and output via VersaWorks. |
| ③ | VersaWorks 7 | Software RIP (Raster Image Processor). For more information on the functions, see the VersaWorks 7 manuals . |
| ④ | Utility | Software that is needed to operate the machine. The major functions are shown below. <ul style="list-style-type: none"> Settings and adjustments Management of ink remaining amount Maintenance Display of messages and error messages |

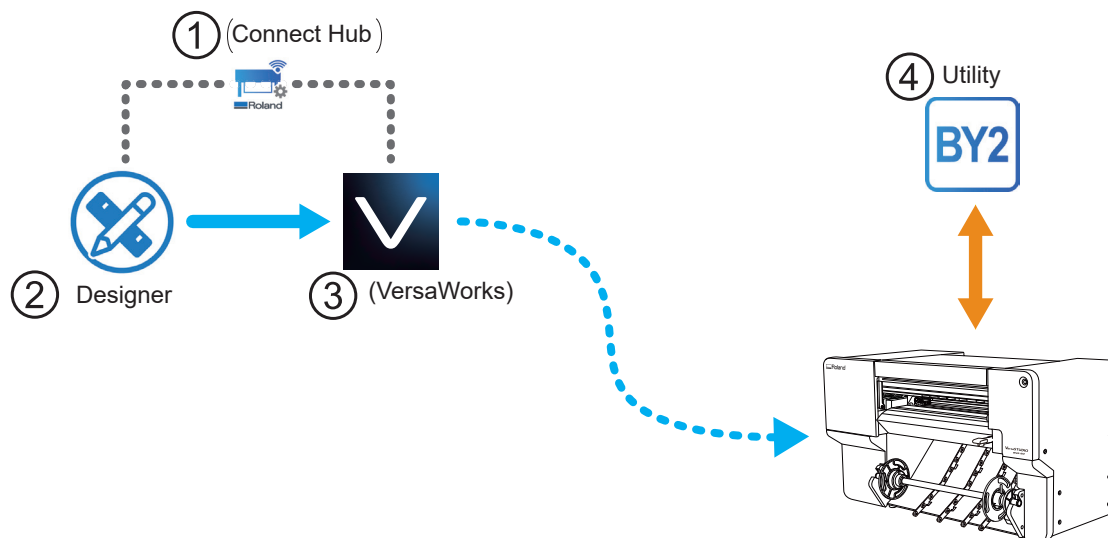

When using commercially available design software such as Adobe Illustrator or CorelDRAW, the created data (.pdf, .ai, etc.) can be imported into Designer for editing. The data can also be directly imported into VersaWorks and output after configuring the print properties.

Network Configuration Example

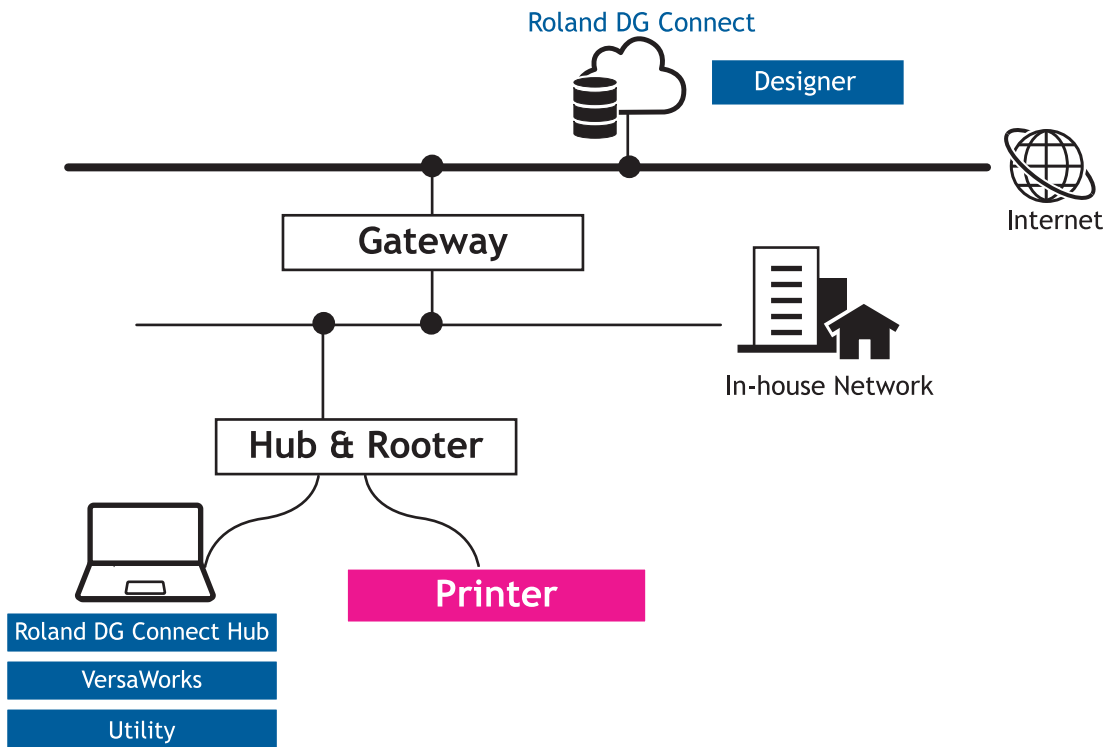

Network Settings

Configuring the Computer's Network Settings

The machine and computer support the automatic assignment of IP addresses via DHCP. If there is a DHCP server on your local network, no configuration of special settings is required.

Check that **[Obtain an IP address automatically]** is set within the network settings for the computer being used.

Windows

This manual contains operation explanations for the following versions. Operations and names may vary depending on the version and build of the OS.

- Windows 11
Version: 24H2

Procedure

1. Log on to Windows as the **[Administrator]** or a member of the **[Administrators]** group.
2. Open Control Panel.
Search for "Control Panel" from the taskbar.
3. Click **[Network and Sharing Center]**.
4. Click **[Ethernet]** or **[Wi-Fi]**.
5. Click **[Properties]**.
If a **[User Account Control]** window appears, click **[Continue]**.
The **[Ethernet Properties]** or **[Wi-Fi Properties]** window appears.
6. Select **[Internet Protocol Version 4 (TCP/IPv4)]**, and then click **[Properties]**.
If the **[Internet Protocol]** check box is clear, select it.

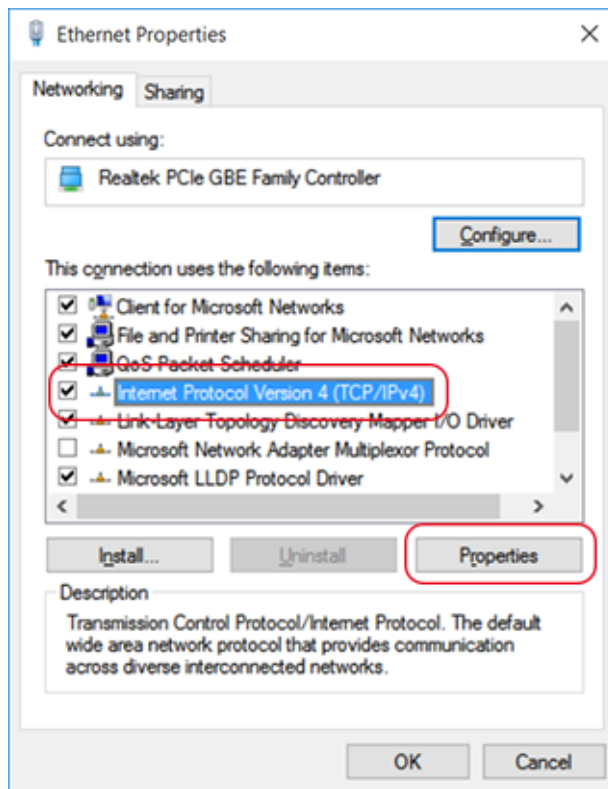

7. Confirm that [Obtain an IP address automatically] is checked.
If it is not checked, click the box to check it.
8. Click [OK].
9. Click [Cancel] in each window.

This completes the configuration of the network settings. Proceed to [Software Setup\(P. 11\)](#).

Mac

This manual contains operation explanations for the following versions. Operations and names may vary depending on the version and build of the OS.

- macOS: 15.1

Procedure

1. Log on to the Mac as the "Administrator."
2. From the Apple menu, click [System Settings...].
3. Click [Network]>[Wi-Fi] or the network name (when using Ethernet).
4. Click [Details...].
5. Click [TCP/IP].
6. Select [Using DHCP] for [Configure IPv4].

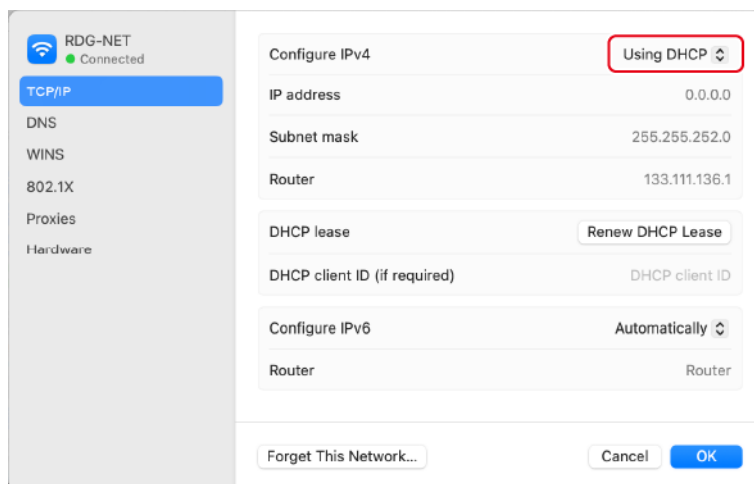

7. Click [OK].

This completes the configuration of the network settings. Proceed to [Software Setup\(P. 11\)](#).

Installing the Software

| | |
|---|----|
| Software Setup..... | 11 |
| Step 1: Creating a Roland DG Connect Account | 11 |
| Step 2: Installing Roland DG Connect Hub..... | 12 |
| Step 3: Signing in to Roland DG Connect Hub..... | 13 |
| Step 4: Registering the Machine to Roland DG Connect Hub | 14 |
| Step 5: Installing VersaWorks from Roland DG Connect Hub..... | 15 |
| Step 6: Configuring VersaWorks Settings..... | 16 |
| Actions to Take When Machine Information Is Not Displayed in Roland DG Connect Hub | 18 |
| Directly Connecting to the Computer | 18 |

Software Setup

Step 1: Creating a Roland DG Connect Account

MEMO

If you already have a Roland DG Connect ID, you do not need to create an account.

Procedure

1. Start the computer.
2. Access the following website.
<https://connect.rolanddg.com/>
3. Click [Sign up], and then create a Roland DG Connect account.
Refer to the Master Initial Setting Guide to create the account.
<https://support.rolanddg.com/hc/articles/43642210630297>

MEMO

You can also use the ID you have acquired to sign in to Roland DG Connect Hub.

Next, download Roland DG Connect Hub from the Roland DG Connect website.

Step 2: Installing Roland DG Connect Hub

Download Roland DG Connect Hub from the Roland DG Connect website and install this software.

Procedure

1. Click  on the sidebar on the Roland DG Connect website.
The Connect Hub download window appears.

MEMO

If you have closed the Roland DG Connect webpage, access the following website and log in.
<https://connect.rolanddg.com/>

2. Download the version of Roland DG Connect Hub that matches the OS of your computer.
3. After downloading Roland DG Connect Hub, install it.
Follow the on-screen instructions to install Roland DG Connect Hub.

Next, sign in to Roland DG Connect Hub.

Step 3: Signing in to Roland DG Connect Hub

MEMO

If you configure the settings to launch Roland DG Connect Hub in the Roland DG Connect Hub setup wizard, Roland DG Connect Hub will start automatically after setup finishes.

Start Connect Hub and sign in.

The method for starting Connect Hub is as follows.

- Windows

Click the [Roland DG Connect Hub] icon () in the notification area.

- Mac

Click the [Roland DG Connect Hub] icon () from the Dock.

To sign in, use the Roland DG Connect ID that you created in [Step 1: Creating a Roland DG Connect Account\(P. 11\)](#).

Next, register the machine in Connect Hub.

Step 4: Registering the Machine to Roland DG Connect Hub

Refer to the procedure below to register the printer to Connect Hub.

<https://support.rolanddg.com/hc/en-us/categories/6469527154585-Roland-DG-Connect>

Step 5: Installing VersaWorks from Roland DG Connect Hub



Use Roland DG Connect Hub to install VersaWorks.

Procedure

1. In the main window of Roland DG Connect Hub, select the machine to use.

MEMO

If you have closed Connect Hub, open it with the following operations.

- Windows
Click the [Roland DG Connect Hub] icon () in the notification area.
- Mac
Click the [Roland DG Connect Hub] icon () from the Dock.

2. Click the VersaWorks icon .

The sidebar is displayed on the right side of the screen.

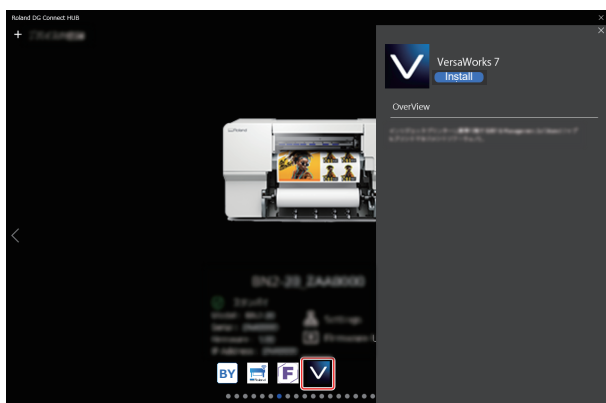

3. Click [Install].

After installation completes, click  to start VersaWorks.

Next, configure VersaWorks (register the machine and create a virtual printer).

Step 6: Configuring VersaWorks Settings

Procedure

1. Make sure the power to the printer is switched on.
2. Click the VersaWorks icon  on the Roland DG Connect Hub home screen.

The sidebar is displayed on the right side of the home screen.

3. Click [Open].

VersaWorks starts.

4. Set the printer to connect.

To register a printer in VersaWorks for the first time, click [Add Printer]. The [Resist Printer] window is displayed, and VersaWorks will search for the connectable printers.

If the search finds zero printers, you will have to register printers manually. If the search finds five or more printers, select the printer to register.

MEMO

If you have used VersaWorks before, the machine information will be displayed on the home screen.

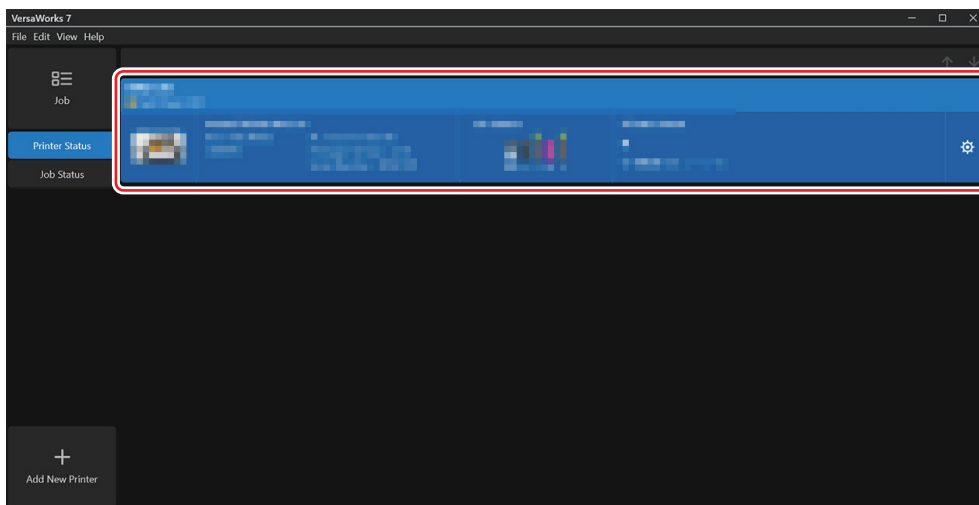

When the detected number of printers is one to four:

- (1) Check the list of detected printers and click [OK] to register all of them.

If there is a printer you do not want to register, click [SKIP]. Register printers manually, referring to the situation in which no printers are detected.

When five or more printers are detected:

- (1) Select the printer to register, and then click [Resister].
The printer details window appears.
- (2) Click [OK].
- (3) Repeat steps (1) and (2) to register printers.

When no printers are detected:

MEMO

If printer search is not possible, check the LAN cable connection status.

- (1) Click [ManualResist].
- (2) Enter the IP address and click [Verify].
Items such as the [Model Name] and [Ink Type] are displayed.
- (3) If there are no problems, click [Resister].

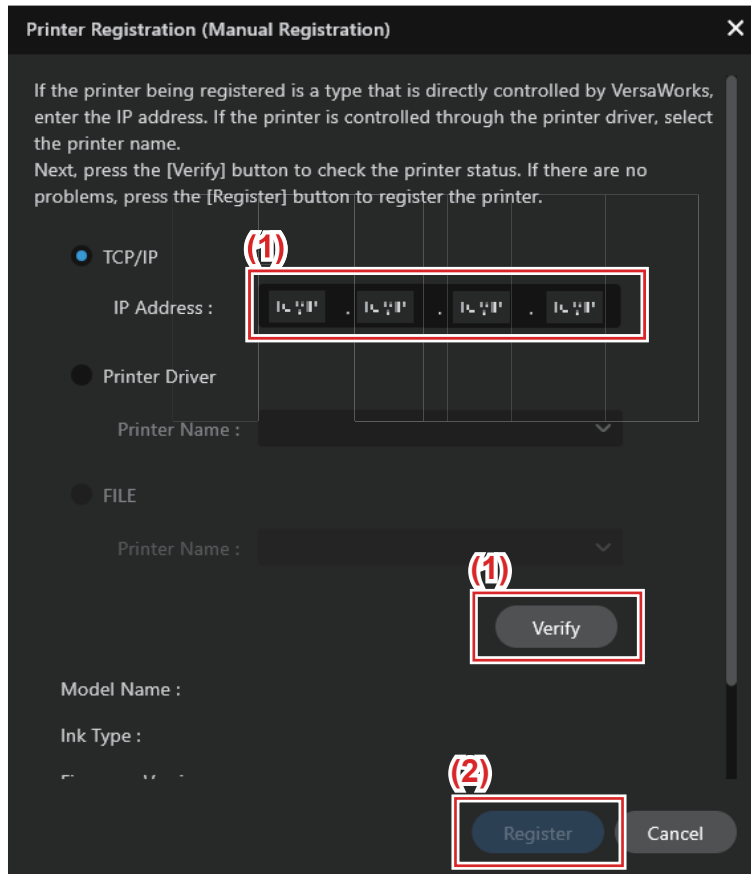

The VersaWorks home screen shows the registered printer(s).

5. Click  to the right of the registered printer, and then click [Create Virtual Printer].
Perform this action on all the registered printers.
6. If you have backed up the VersaWorks settings and job data, restore them.
The previously used VersaWorks settings, etc. are applied to the newly installed computer.

This completes setup.

Actions to Take When Machine Information Is Not Displayed in Roland DG Connect Hub

- If machine information is not displayed in Roland DG Connect Hub, refer to the following and bring the computer and this machine into the same subnet mask.
[P. 6 Network Configuration Example](#)
- If the computer and this machine cannot be brought into the same subnet mask, refer to [Directly Connecting to the Computer\(P. 18\)](#) and connect them directly, and then configure the network settings for the computer and printer.

Directly Connecting to the Computer

This section explains the setting procedure for connecting one computer and one machine directly, not over a network.

IP addresses that start with "192.168." can be used freely by anyone. Use one of these addresses when connecting one computer and one machine in an environment separate from other networks.

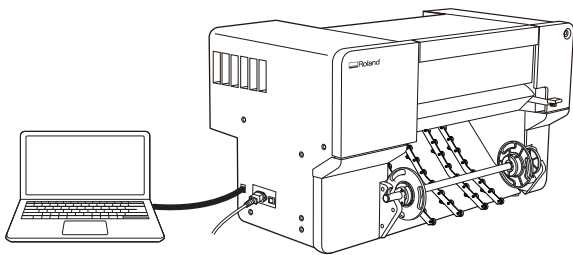

1. Make the Network Settings on the Printer

Procedure

1. On the Utility home screen, click .
2. Click [System Information], and then clear the [Obtain IP Address Automatically] check box under [Network].
3. Enter the [IP Address] and [Subnet Mask].
 - (1) Enter the [IP Address].

| Item | Address to enter |
|-------------|------------------|
| IP address | 192.168.0.XXX |
| Subnet mask | 255.255.255.0 |

Note: Here, "XXX" may be any number you want from 1 to 254.

Here, "192.168.0.3" is entered by way of example.

- (2) Enter the [Subnet Mask].

Enter the same subnet mask as the one used by the computer.

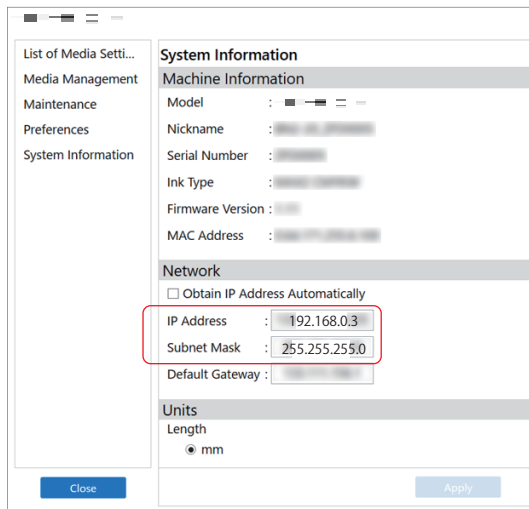

4. Click [Apply].

2. A: Setting the Computer's Network (Windows)

This manual contains operation explanations for the following versions. Operation methods may vary depending on the version and build of the OS.

- Windows 11
Version: 24H2

Procedure

1. Log on to Windows as the [Administrator] or a member of the [Administrators] group.
2. Open Control Panel.
Search for "Control Panel" from the taskbar.
3. Click [Network and Sharing Center].
4. Click [Ethernet].
5. Click [Properties].
If a [User Account Control] window appears, click [Continue].

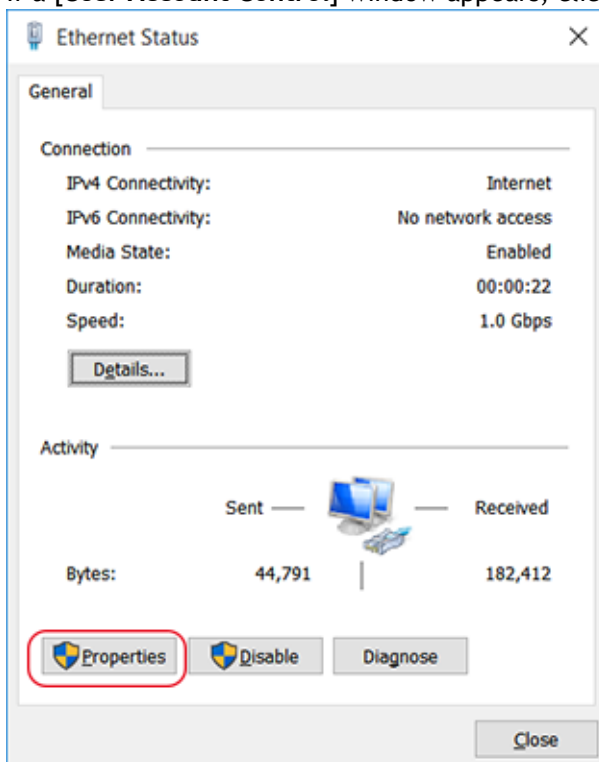

The [Ethernet Properties] screen appears.

6. Select [Internet Protocol Version 4 (TCP/IPv4)], and then click [Properties].
If the [Internet Protocol] check box is clear, select it.

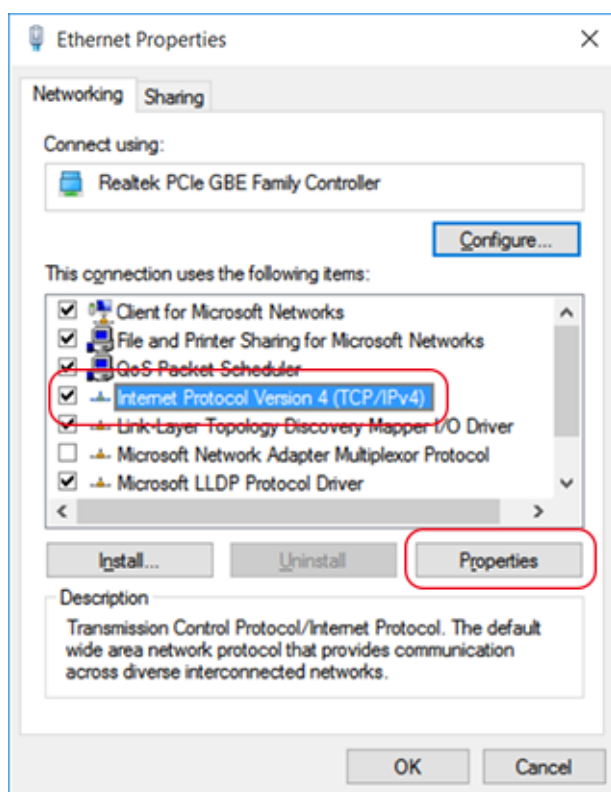

7. Select [Use the following IP address], enter the IP address and subnet mask, and click [OK].

MEMO

The addresses in the following table are examples used for the explanations in this manual. Enter the desired IP address and subnet mask.

| Item | Address to enter |
|-------------|------------------|
| IP address | 192.168.0.XXX |
| Subnet mask | 255.255.255.0 |

"XXX" represents a number from 1 to 254. However, do not use the same number as set in "Make the Network Settings on the Printer."

8. Click the following buttons to return to the original state.
 - a. [Cancel] in the [Ethernet Properties] window
 - b. [Cancel] in the [Ethernet Status] window

2. B: Setting the Computer's Network (Mac)

MEMO

The following operation procedure uses macOS 15.1. Operation methods may vary depending on the version of Mac OS or the build of the OS.

Procedure

1. Log on to the Mac as the "Administrator."
2. From the Apple menu, click [System Settings...].
3. Click [Network]>[Wi-Fi] or the network name (when using Ethernet).
4. Click [Details...].
5. Click [TCP/IP].
6. Select [Manually] for [Configure IPv4].
7. Enter the [IP address] and [Subnet mask].

MEMO

The addresses in the following table are examples used for the explanations in this manual. Enter the desired IP address and subnet mask.

| Item | Address to enter |
|-------------|------------------|
| IP address | 192.168.0.XXX |
| Subnet mask | 255.255.255.0 |

Here, "XXX" can be any number from 1 to 254. Ensure that it is different from the numbers of other equipment.

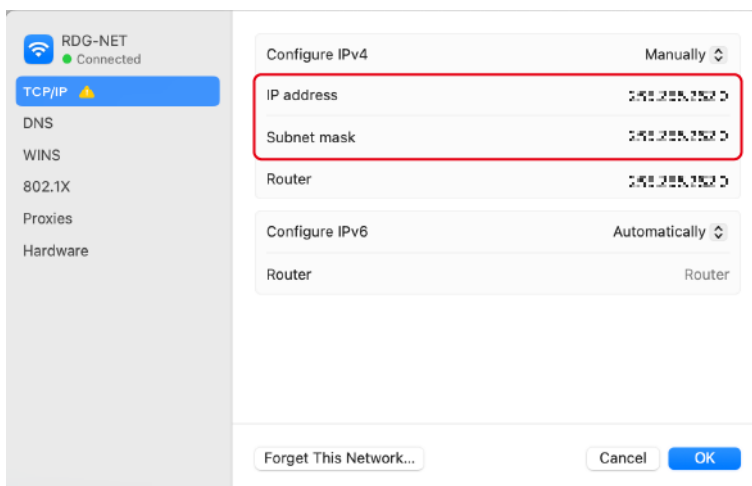

8. Click [OK].

Initial Printer Settings

| | |
|--|----|
| Media | 24 |
| Loading the Roll Media on the Printer | 25 |
| Installing the Cutting Tool..... | 29 |
| Step 1: Assemble the Cutting Tool..... | 29 |
| Step 2: Installing the Cutting Tool | 30 |
| Step 3: Adjusting the Amount of Blade Extension..... | 31 |
| Ink Filling and Initial Adjustment | 32 |
| Step 1: Filling the Machine with Ink | 32 |
| Step 2: Media Setup..... | 35 |
| Step 3: Performing a Nozzle Drop-Out Test | 44 |
| Step 4: Performing Automatic Correction | 45 |
| Step 5: Performing Blade Adjustment..... | 46 |

Media

Media type

In this manual, the paper used for output is called "media." The two main types of media used in this machine are shown below.

- Roll media: Media wound onto a paper tube
- Sheet media: Media not wound onto a paper tube such as standard-size media

Various paper qualities of roll media and sheet media are selectable according to the purpose. For detailed information about each media, contact your media supplier. Media can also be purchased from our website.

<https://www.rolanddg.com/>

Usable media

This machine cannot print on every kind of media. Before selecting media, be sure to perform trial printing to check whether satisfactory output quality is obtained.

Size

| | Usable Media |
|---|---|
| Width *1 | 150 to 515 mm (5.9 to 20.3 inches) |
| Cutable media thickness*1 | Max. 0.22 mm (8.66 mil; depending on the media composition) |
| Maximum media thickness (including backing paper)*1 | When only printing: 1.0 mm (39.37 mil) When performing cutting: 0.4 mm (15.75 mil) |
| Maximum roll outer diameter | 150 mm (5.9 in.) |
| Paper tube (core) inner diameter | 76.2 mm (3 in.) or 50.8 mm (2 in.) |

*1 Applies to both roll and sheet media

Maximum roll weight

6 kg (13.23 lb.)

Other conditions

Media such as the following cannot be used.

- Media whose end is attached to the paper tube (core)
- Media that is severely warped or that has a strong tendency to reroll
- Media that cannot withstand the heat of the media heating system
- Media whose paper tube (core) is bent or crushed
- Media that bends under its own weight when loaded
- Media on a sagging roll
- Media that is rolled unevenly

Loading the Roll Media on the Printer

Load the roll media onto the media flange and then load it in the machine. This procedure is not necessary when using sheet media.

MEMO

Use the following link to view a reference video for this procedure. We recommend that you view this video to understand the overall flow of work.

<https://vimeo.com/1003476467/d0c94b8c81>

The BN2-20/20A is shown in this video, but the work and operation procedures are the same for this machine.

Procedure

1. Remove the media shaft from the machine.
2. Open the lock lever (①) on the left media flange in the direction of the arrow, and remove the flange from the media shaft.

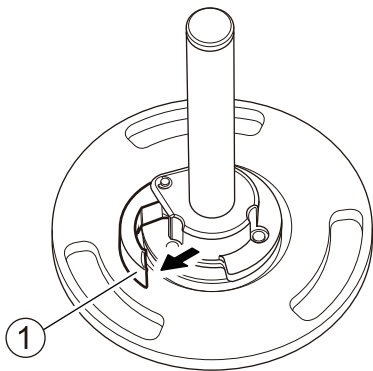

3. Check the orientation of the right media flange (①).

With the factory default settings, the right media flange is installed so that loading of roll media with a 3-inch paper tube inner diameter is possible.

To load roll media with a 2-inch paper tube inner diameter, change the orientation of the right media flange using the following procedure.

- (1) Remove the snap pin (②) and pull out the mounting pin (③).
- (2) Remove the right media flange from the media shaft (④).
- (3) Change the orientation of the right media flange and install it on the media shaft with the 3-inch side (⑤) facing the stopper (⑥).
- (4) Secure the right media flange and media shaft with the mounting pin, and then attach the snap pin.

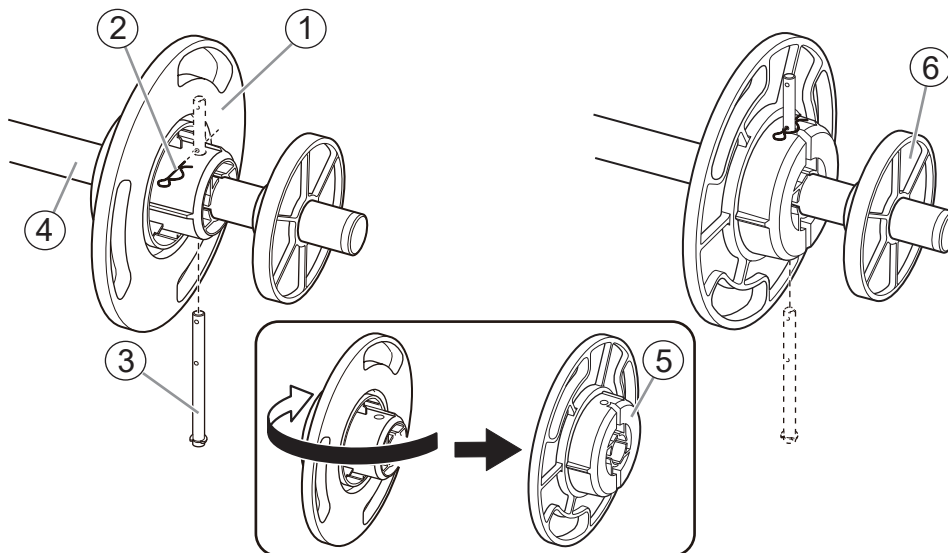

4. Load the roll media onto the media flange.

Place the media shaft flange at the bottom and load the roll media so that the media feeds in the clockwise direction when viewed from above.

MEMO

Media cannot be loaded correctly if the direction of the roll media is incorrect.

Install the roll media so there is no gap between it and the media flange.

To keep the printing result from being negatively affected, prevent contact with the media print surface as much as possible.

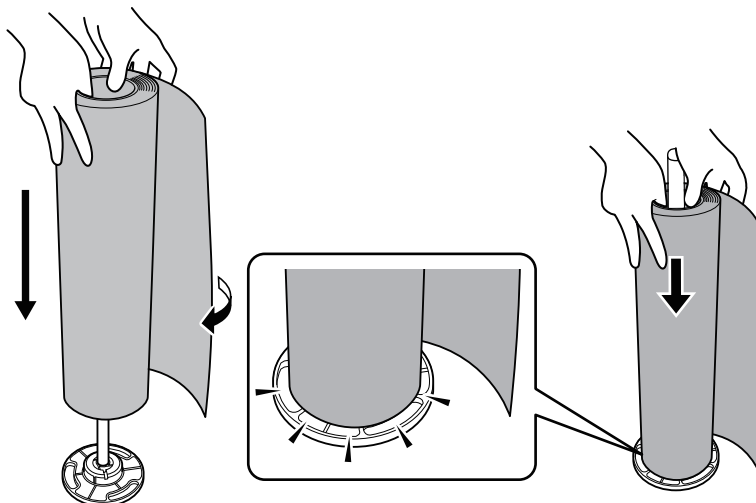

5. Install the left media flange.

Install the media flange so there is no gap between it and the roll media.

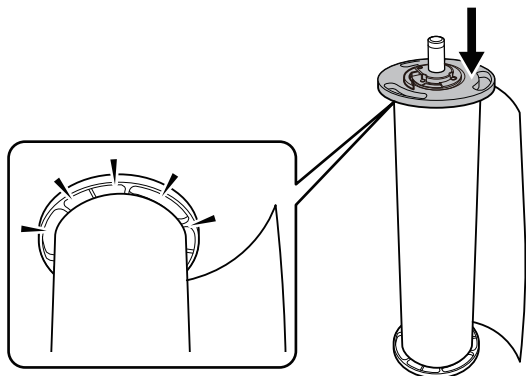

6. Secure the left media flange in place.

Close the lock lever in the direction of the arrow to secure the left media flange in place.

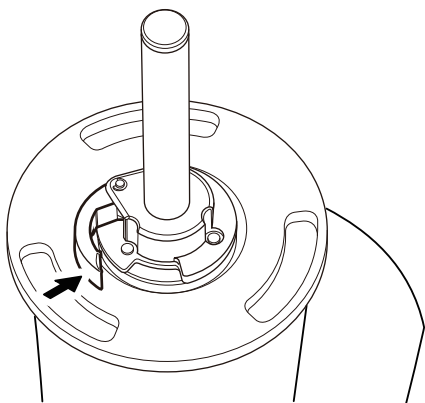

7. Load the roll media on the printer.

IMPORTANT

When loading the media, hold by the media flange to prevent contact with the media print surface.

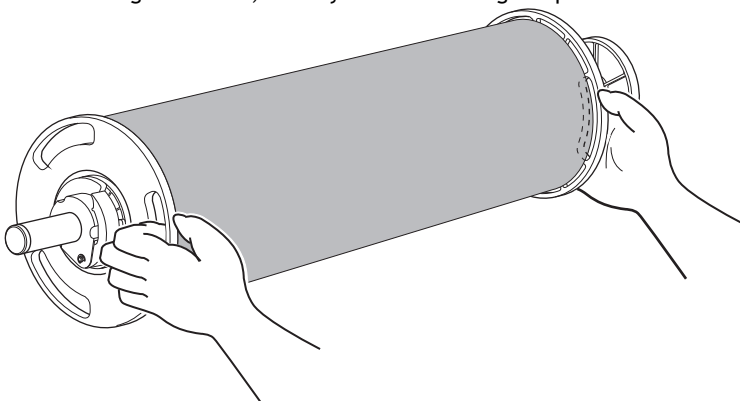

(1) Align the stopper (①) with the guide (②).

(2) Press the left and right ends of the media shaft into the shaft holder until you hear a click.

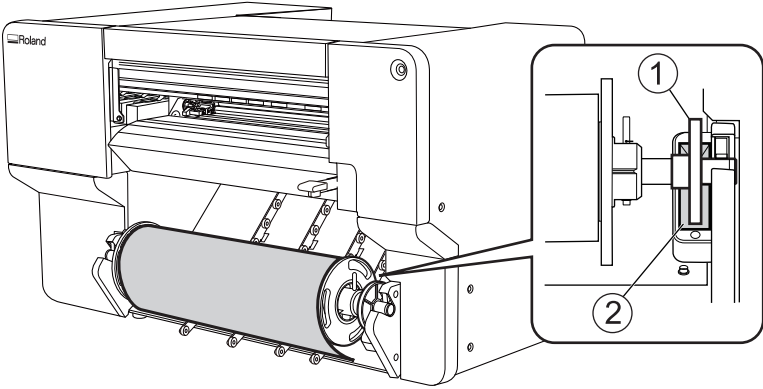

Installing the Cutting Tool

This operation is unnecessary if you will not use the cutting tool.

Tighten the print-head carriage screw lightly when no cutting tool is installed. Keeping the screw firmly tightened causes the cutting tool insertion hole to become gradually smaller, making installation difficult.

⚠ WARNING

Be sure to perform operations as specified by the instructions, and never touch any area not specified in the instructions.

Sudden movement of the machine may cause injury.

⚠ CAUTION

Never touch the tip of the knife.

Doing so may result in injury. The cutting performance of the blade will also be impaired.

Step 1: Assemble the Cutting Tool

Procedure

1. Insert the pin into the blade holder.

Insert the pin until the tip protrudes about 3 to 5 mm (0.12 to 0.19 in.).

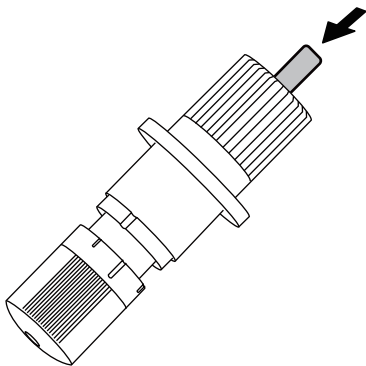

2. Insert the blade into the blade holder.

Insert the blade into the hole so the blade tip is on the outside.

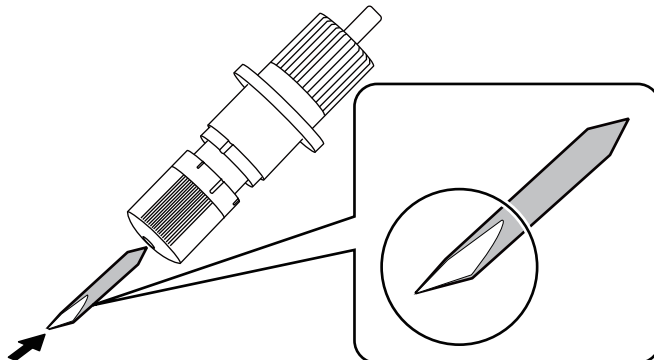

Step 2: Installing the Cutting Tool

Procedure

1. Open the front cover.

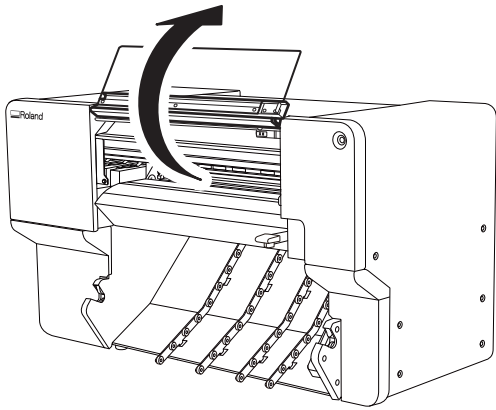

2. Loosen the print-head carriage screw.

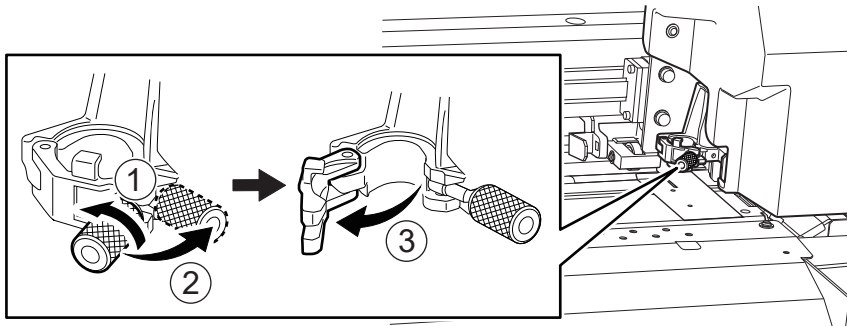

3. Install the cutting tool in the print-head carriage.

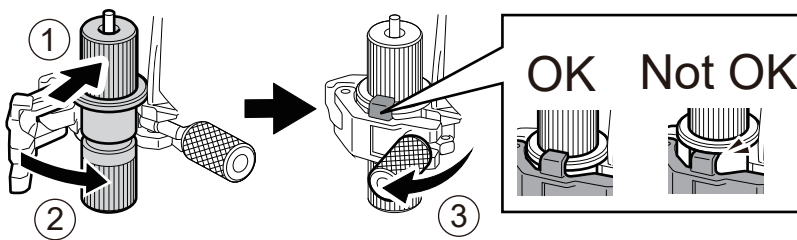

4. Tighten the screw.

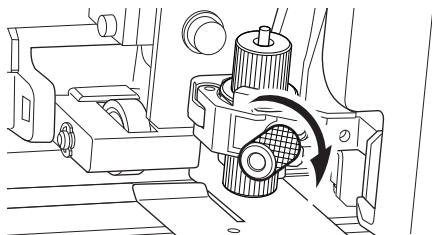

5. Close the front cover.

Step 3: Adjusting the Amount of Blade Extension

When you want to perform accurate and fine adjustment of the cutting-in amount, such as when cutting media with thin backing paper, you can obtain good results by adjusting the amount of blade extension (③). Turn the cap portion of the blade holder to adjust the amount of blade extension. Each indicator tick corresponds to 0.1 millimeters, and adjustment for 0.5 millimeters can be made by rotating the cap one full turn.

Note that making the amount of blade extension too small may cause the tip of the blade holder cap to touch the printed surface, soiling and damaging it. It is important to be especially careful about this when you are using media that has poor ink-adhesion properties.

The amount of blade extension (③) is 0 mm (①) at minimum and 2.5 mm (98.42 mil) (②) at maximum.

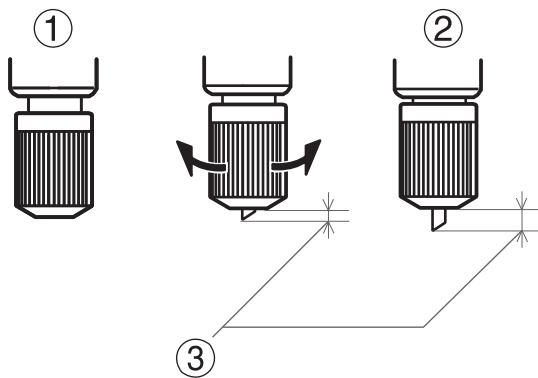

Rough Estimate for the Amount of Blade Extension

Set the amount of blade extension to an amount that is the sum (①) of the thickness of the material portion (②) and half (④) the thickness of the backing paper (③).

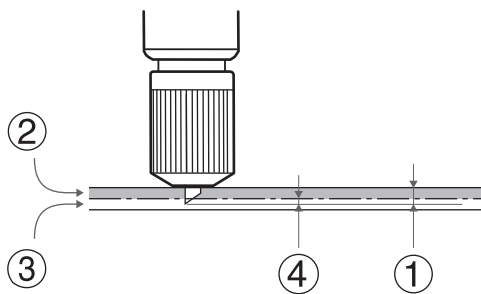

Ink Filling and Initial Adjustment

Fill the machine with ink and perform initial adjustment.

Initial adjustment of the printer will be completed in [Step 4: Performing Automatic Correction\(P. 45\)](#) if no cutting tool is used.

Refer to the user's manual and videos for more detailed usage information.

<https://downloadcenter.rolanddg.com/BY2-20>

Step 1: Filling the Machine with Ink

Use Utility to operate the machine.

Procedure

1. Close the front cover.
2. Turn on the main power switch.

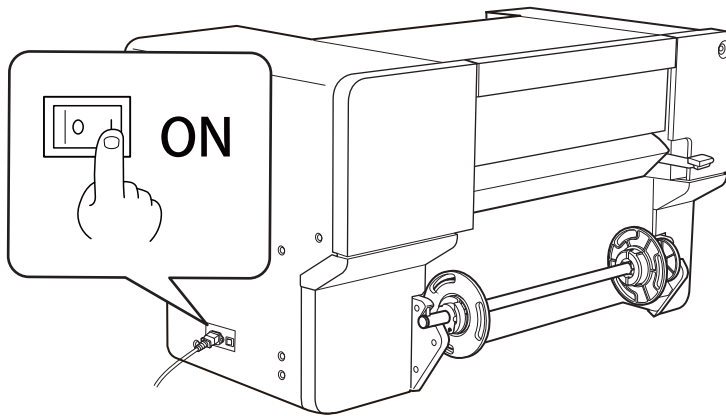

3. Press the sub power button.

When the sub power button indicator changes from flashing to steady, startup is finished.

MEMO

After turning on the main power, wait some time before pressing the sub power button.

Firmware initialization starts when the main power is turned on, and there will be no response when pressing the sub power button until initialization is complete.

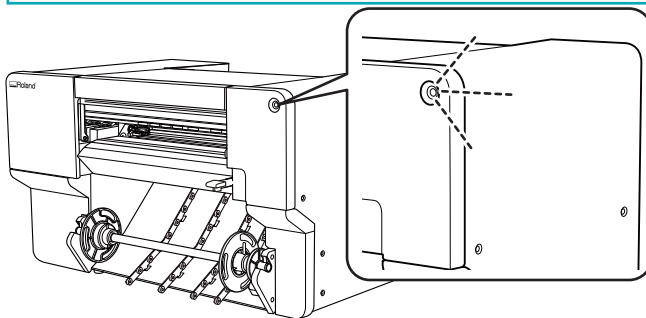

4. Start Utility from the Roland DG Connect Hub home screen.
 - (1) Click the Utility icon.
 - (2) Click [Open].

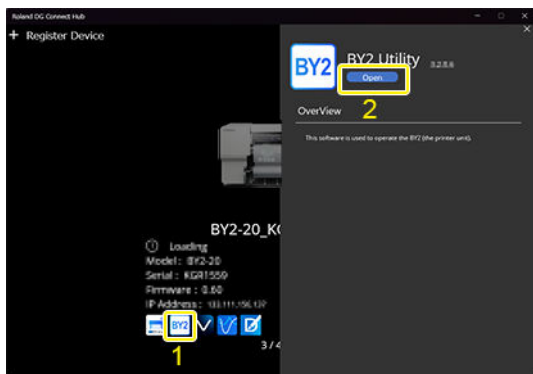

5. When the Operation Guide window appears, click [Next].

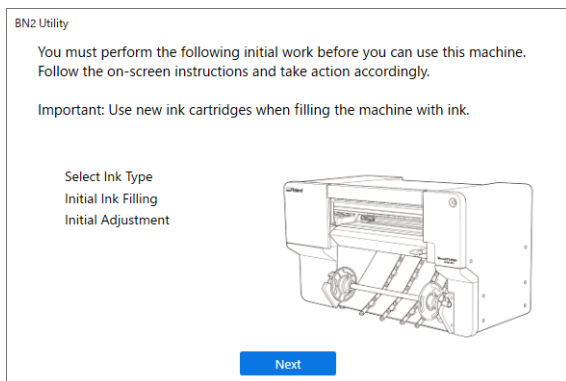

6. Select the type of ink being used for filling, and then click [Next].

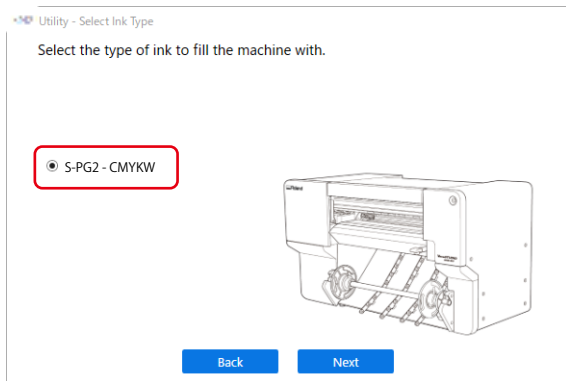

7. When the ink type confirmation window appears, click [Next] if everything looks OK.

8. When the window for starting ink filling appears, click [Next].

9. Follow the on-screen instructions to shake the ink cartridge, and then click [Next].

10. Insert all of the ink cartridges into the ink slots until a beep is heard.
Be sure to insert the ink cartridges into the ink slots with the same colors as the ink labels.

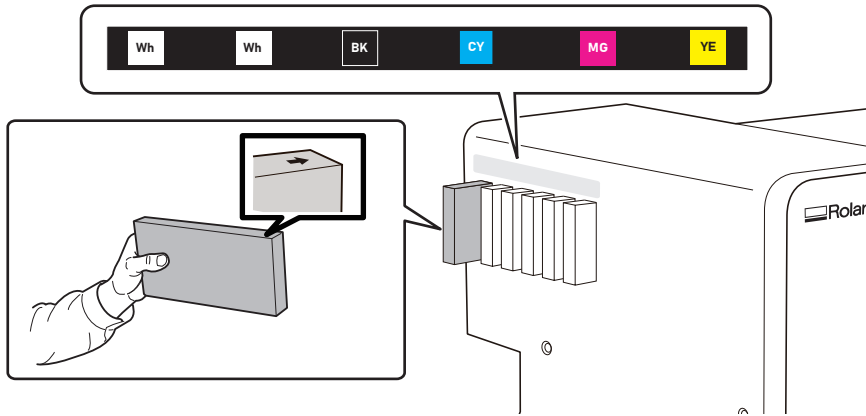

11. When the [The ink tanks have been filled. Click [Next].] window appears, click [Next].

Next, set the media and perform initial adjustment. Proceed with the work by following the on-screen instructions.

Step 2: Media Setup

Loading media onto the machine and preparing it for printing is called "media setup."

When [Load the media, and then make sure that the loading lever is lowered. Start setup.] is displayed, load the media onto the machine while referring to the setup instructions for the media being used. After that, load media that is at least 400 mm (15.75 in.) wide and 600 mm (23.63 in.) long to perform test printing and various adjustments.

- When using roll media: [Setting Up Roll Media\(P. 35\)](#)
- When using sheet media: [Setting Up Sheet Media\(P. 40\)](#)

Setting Up Roll Media

MEMO

Use the following link to view a reference video for this procedure. We recommend that you view this video to understand the overall flow of work.

<https://vimeo.com/1003476339/5eb7f8a611>

The BN2-20/20A is shown in this video, but the work and operation procedures are the same for this machine.

Procedure

1. Open the front cover.

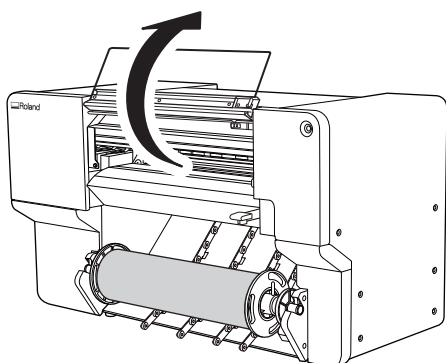

2. Move the right pinch roller (①) and the right media clamp (②) to the right end.

Press the part indicated by the arrow on the right pinch roller to move the roller and the right media clamp together.

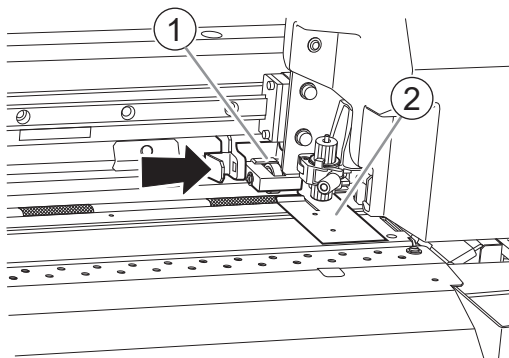

3. Move the left pinch roller (①) and the left media clamp (②) to the left end.

Press the part indicated by the arrow on the left pinch roller to move the roller and the left media clamp together.

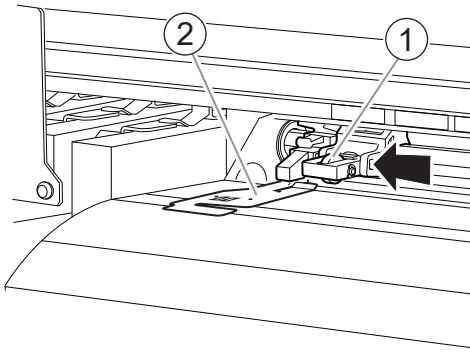

4. Use the following procedure to load the media.

- (1) Pull out the media and load it from above the plate in front with the arrow stickers.

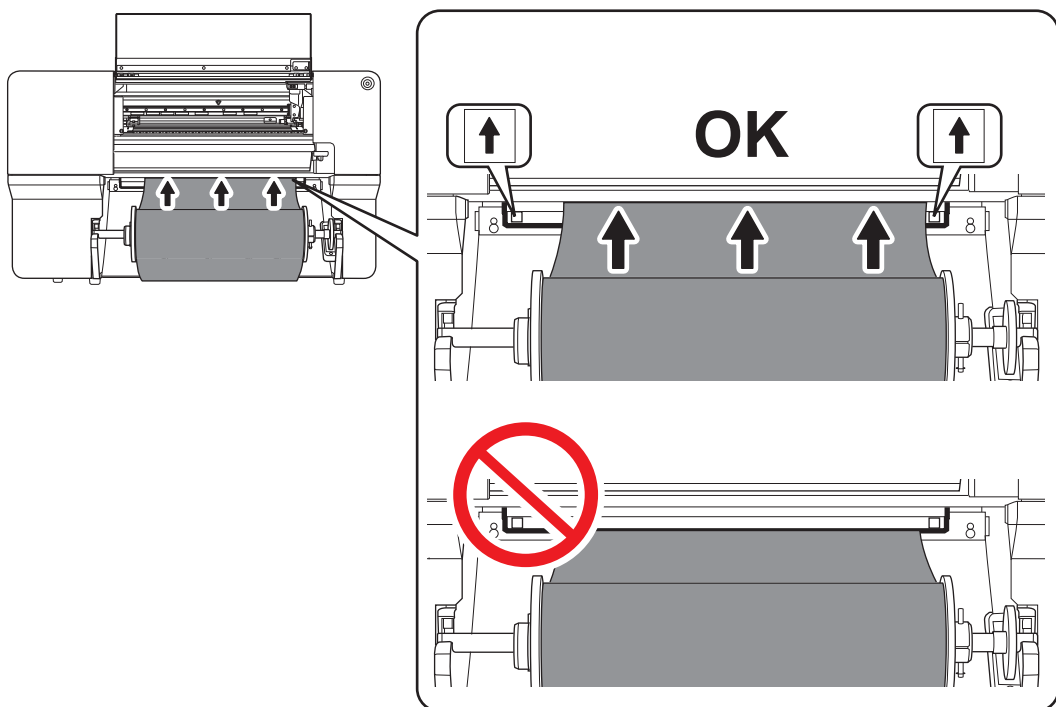

- (2) Pass the media (①) between the right grit roller (②) and right pinch roller (③).

MEMO

If the left edge of the media is left of the left pinch roller, pass the media between the left grit roller and left pinch roller as well.

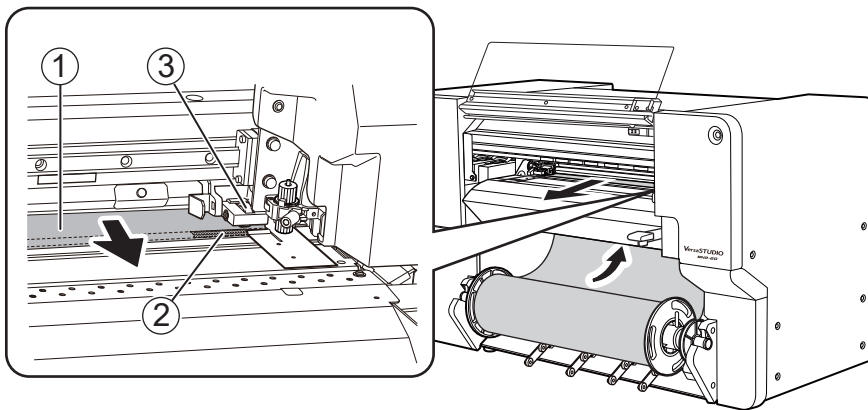

- (3) Pass the media (①) under the right media clamp (②), and pull it out about 20 cm (7.87 in.) from the edge of the apron (③).

MEMO

If the left edge of the media hits the left media clamp, pass the media under the left media clamp.

MEMO

You will hear a beep. Approximately 2 seconds later, you will hear two beeps, and then the suction fan will activate. While this fan is operating, the position of the media will be maintained even if you remove your hands from it.

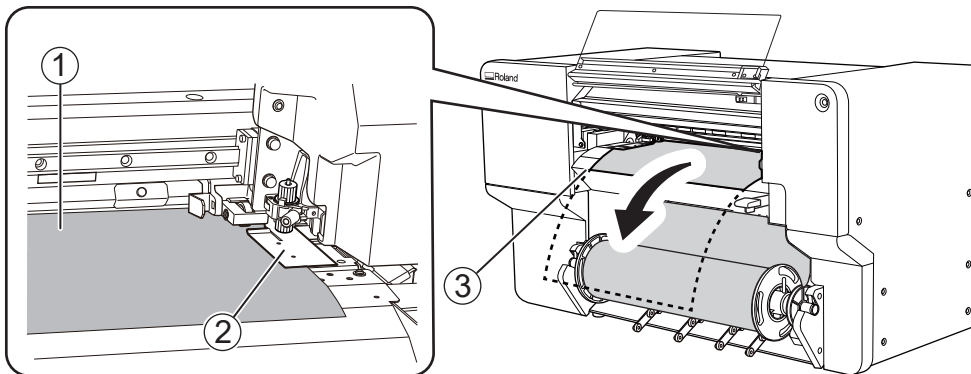

- (4) Hold the media holder flange and take up about 20 cm (7.87 in.) of media.

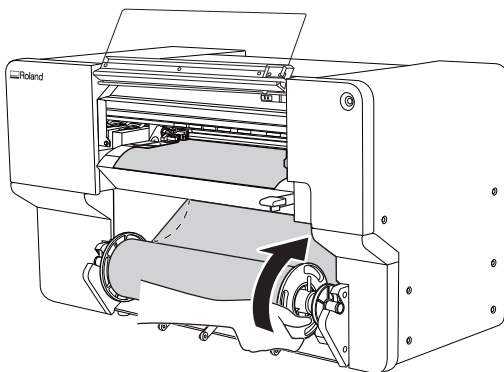

MEMO

Do not take up so much media (①) that the sensor (②) becomes visible.

If you take up too much media, you will hear two short beeps and the suction fan will stop. If the media comes off or is not straight, take up the media and redo the procedure from step 4.

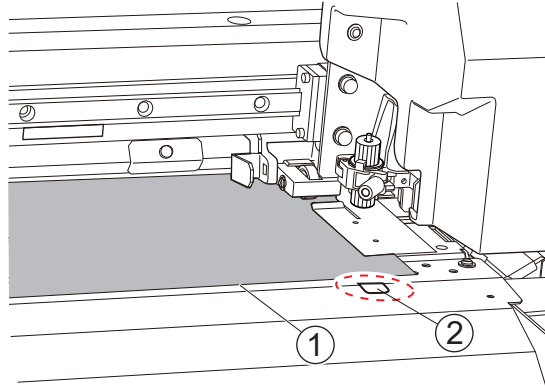

5. Place the left media clamp and the left pinch roller.

Place the left pinch roller (2) within the grit pattern (1).

Ensure that margin A from the left edge of the media to the left pinch roller is about 10 mm (0.39 in.).

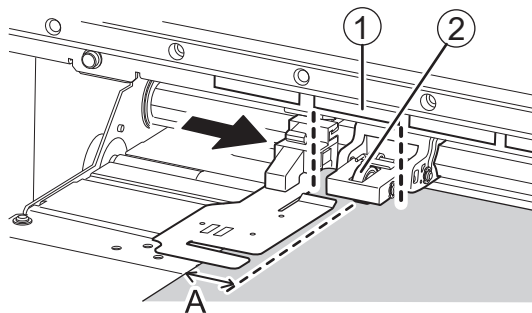

6. Lower the loading lever.

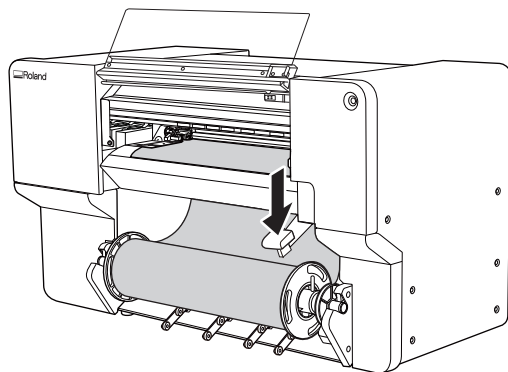

7. Line up the edges of the media with the centers of the holes of the left media clamp.

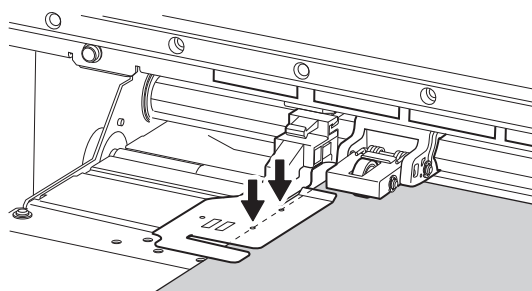

8. Close the front cover.

9. Click [OK].

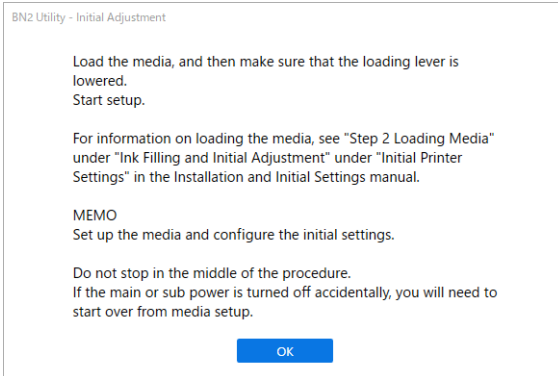

Setting Up Sheet Media

When setting up sheet media in the machine, use the right edge of the media as a reference. This is because the range of movement of the right pinch roller is fixed.

Place the media in a position where the following conditions are met and where media waste will be minimized.

- Position of right edge of media

Within the right pinch roller movable range and where about 10 mm (0.39 in.) between the right roller edge of the right pinch roller and the right edge of the media can be secured.

- Position of left edge of media

Where about 10 mm (0.39 in.) between the left edge of the roller and the left edge of the media can be secured when placing the left pinch roller within the range of the grit pattern.

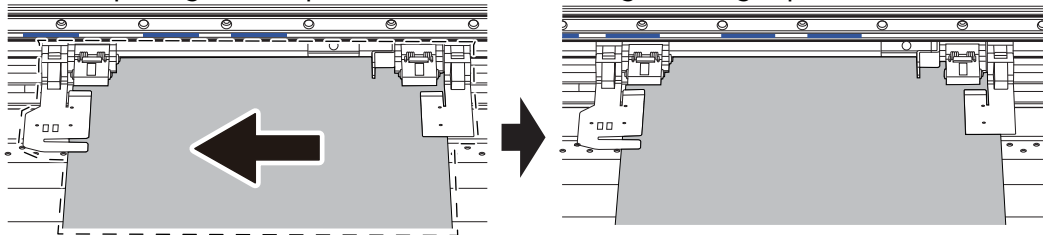

MEMO

Use the following link to view a reference video for this procedure. We recommend that you view this video to understand the overall flow of work.

<https://vimeo.com/1003475093/b41e56efdf>

The BN2-20/20A is shown in this video, but the work and operation procedures are the same for this machine.

Procedure

1. Open the front cover.

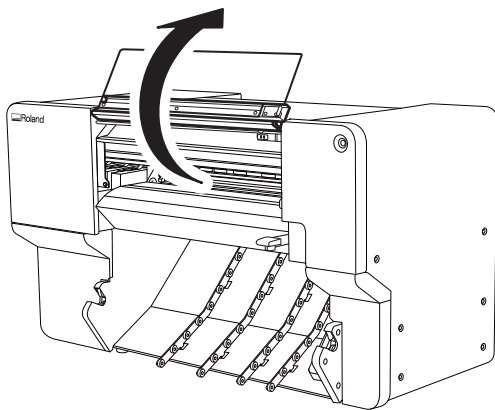

2. Move the right pinch roller (①) and the right media clamp (②) to the right end.

Press the part indicated by the arrow on the right pinch roller to move the roller and the right media clamp together.

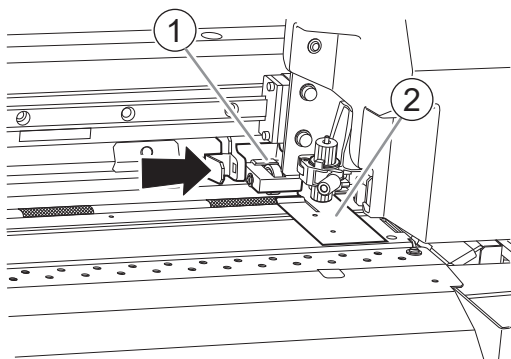

3. Move the left pinch roller (①) and the left media clamp (②) to the left end.

Press the part indicated by the arrow on the left pinch roller to move the roller and the left media clamp together.

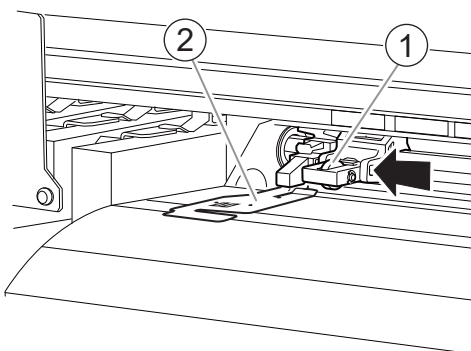

4. Use the following procedure to load the media.

- (1) Pass the media (①) under the right media clamp (②).

MEMO

If the left edge of the media hits the left media clamp, pass the media under the left media clamp.

MEMO

Lifting the tip of the media clamp to pass the media through may cause the blade to come into contact with the media. Be careful not to allow contact with the blade.

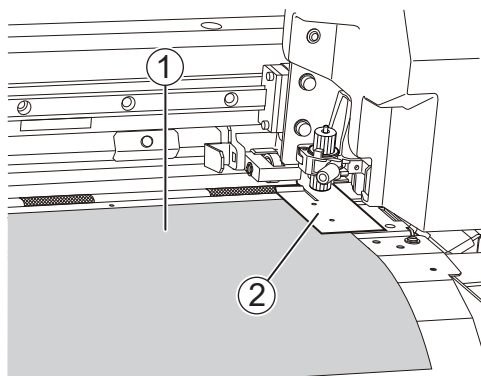

- (2) Pass the media (①) between the right grit roller (②) and right pinch roller (③) to the back.
Feed the media and line up the edge of the media with the edge of the apron (④).

MEMO

If the left edge of the media is left of the left pinch roller, pass the media between the left grit roller and left pinch roller as well.

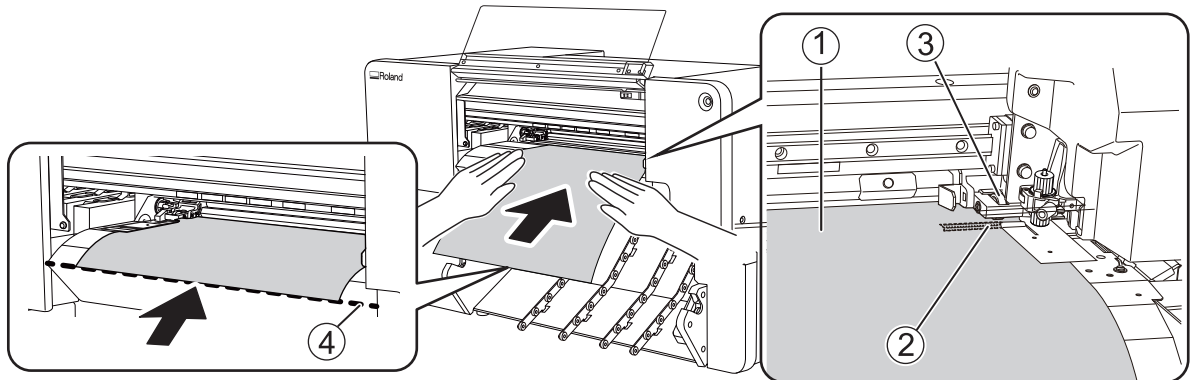

5. Straighten the media.

OK

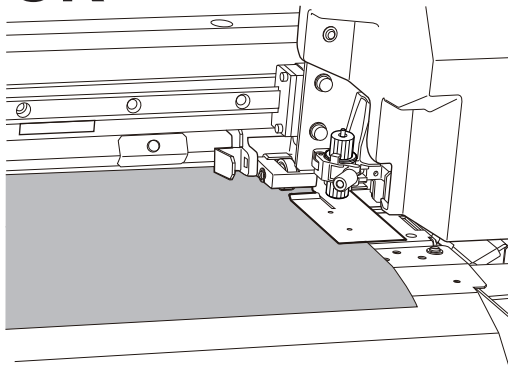

Not OK

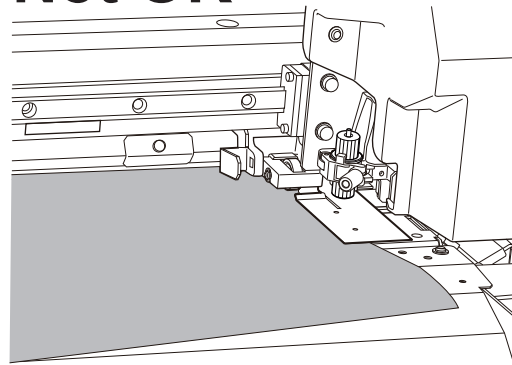

6. Press lightly on the media, and place the left media clamp and left pinch roller on the media. Place the left pinch roller (2) within the grit pattern (1).

Ensure that margin A from the left edge of the media to the left pinch roller is about 10 mm (0.39 in.).

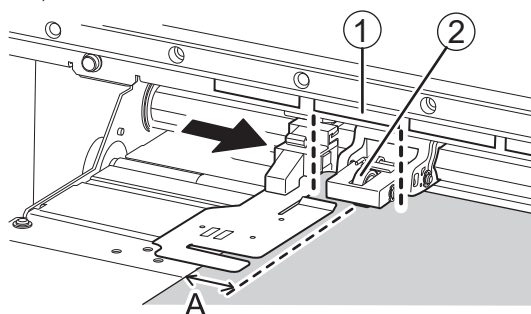

MEMO

If 10 mm (0.39 in.) cannot be ensured for margin A from the left edge of the media to the left pinch roller, move the right pinch roller and the media to the left to provide the margin. The range of motion of the right pinch roller is fixed. Place the right pinch roller within the movable range in a position that ensures margin A from the right edge of the media to the right pinch roller is about 10 mm (0.39 in.).

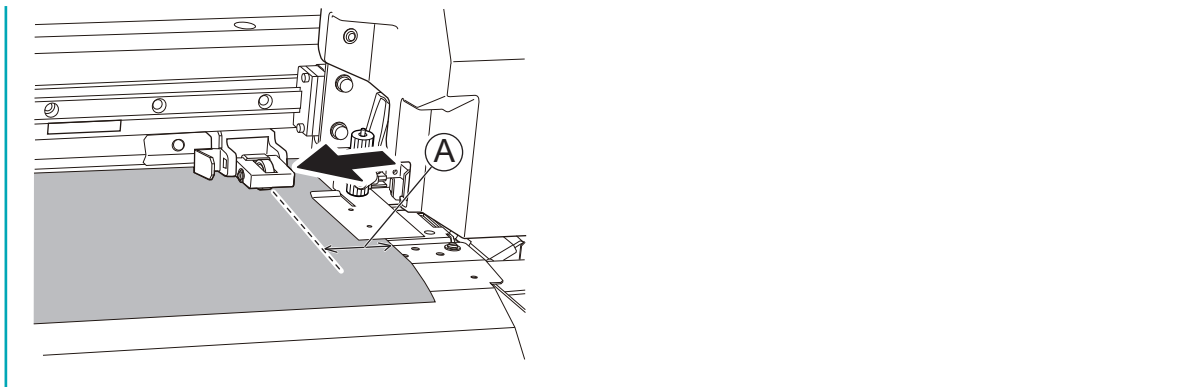

7. Lower the loading lever.

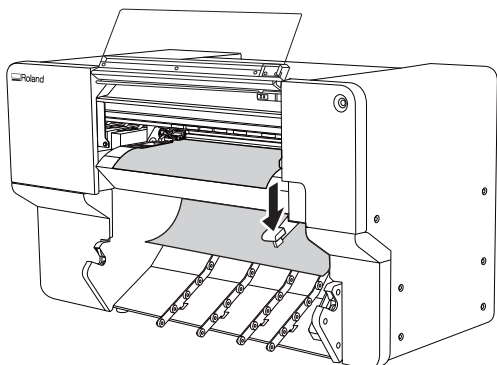

8. Line up the edges of the media with the centers of the holes of the left media clamp.

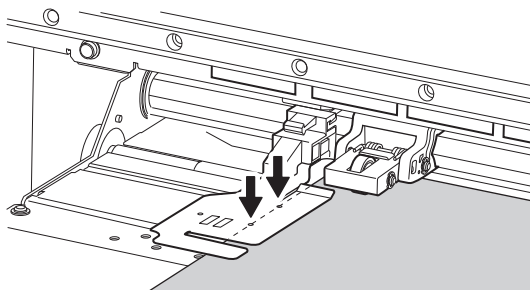

9. Close the front cover.

10. Click [OK].

BN2 Utility - Initial Adjustment

Load the media, and then make sure that the loading lever is lowered.
Start setup.

For information on loading the media, see "Step 2 Loading Media" under "Ink Filling and Initial Adjustment" under "Initial Printer Settings" in the Installation and Initial Settings manual.

MEMO
Set up the media and configure the initial settings.

Do not stop in the middle of the procedure.
If the main or sub power is turned off accidentally, you will need to start over from media setup.

Step 3: Performing a Nozzle Drop-Out Test

Check the print head ink discharge conditions.

MEMO

Use the following link to view a reference video for this procedure. We recommend that you view this video to understand the overall flow of work.

<https://vimeo.com/1003475749/6df9f81a6c>

The BN2-20/20A is shown in this video, but the work and operation procedures are the same for this machine.

Procedure

1. Click [Output].

Printing of the test pattern starts.

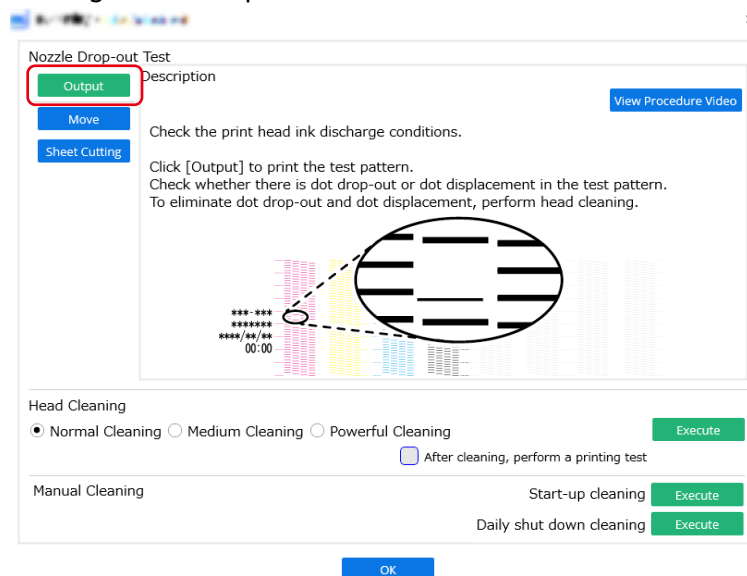

2. Check whether there is dot drop-out or dot displacement in the test pattern.



Missing blocks indicate dot drop-out. Collapsed or inclined blocks indicate dot displacement.

- If there is no dot drop-out or dot displacement, click [OK].
- If dot drop-out or dot displacement is present, perform cleaning.

MEMO

Even if nozzle drop-out does not appear to be improved by cleaning, it may be possible to ignore the effect on products if drop-out occurs in just a few locations. Try printing. If you can judge that the product is not affected, use the printer without any further cleaning.

Step 4: Performing Automatic Correction

Automatically correct the media feed amount and ink landing position.

Procedure

1. Click [OK].

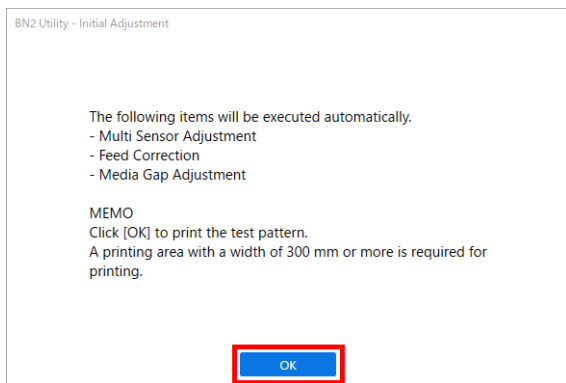

A test pattern will be printed for automatic correction.

MEMO

Automatic correction may not finish depending on the characteristics of media such as transparent media and silver media with high light reflectance. In these situations, click [Skip]. Clicking [Skip] applies the standard value.



When correction is complete, the blade adjustment window will be displayed.

If you are not using the blade, this completes the initial adjustment. Start operation according to the user's manual.

RELATED LINKS

- [BY2-20 User's Manual](#)

Step 5: Performing Blade Adjustment

Set up the media to cut and adjust the cutting quality of the blade.

If you are not using the blade, complete the initial adjustment by clicking [OK] without adjusting the blade. Then, start operation.

MEMO

Use the following link to view a reference video for this procedure. We recommend that you view this video to understand the overall flow of work.

<https://vimeo.com/1003474895/208e3298e2>

The BN2-20/20A is shown in this video, but the work and operation procedures are the same for this machine.

Procedure

1. Make sure the cutting tool is installed, and then click [Next].

If no cutting tool has been installed, install one.

[Installing the Cutting Tool](#)

2. Click [Output].

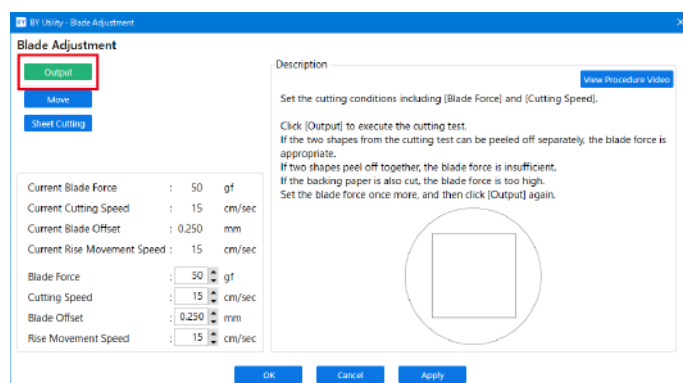

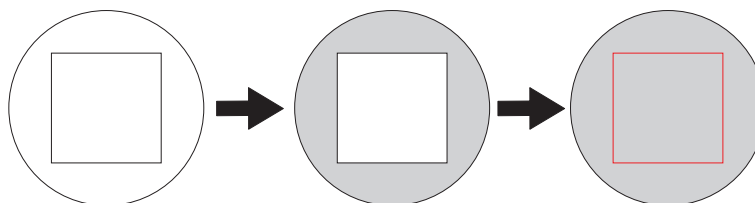

A cutting test will be performed.

3. Check the cutting results.



| Check item | Result | Setting item | Adjustment |
|----------------------|--|-----------------|------------|
| Check the shape. | The cut shape is distorted. | [Cutting Speed] | Reduce |
| Peel off the circle. | The square also peels off. | [Blade Force] | Increase |
| | Some uncut areas remain. | [Cutting Speed] | Reduce |
| Peel off the square. | The blade leaves faint traces on the backing paper. | [Cutting Speed] | No change |
| | The blade trace is indistinct. | | Increase |
| | The blade trace is too deep and cuts into the backing paper. | | Reduce |

| Check item | Result | Setting item | Adjustment |
|--|---|--|-----------------------------|
| Check the shape of the square you have peeled off. |  | The corners are not rounded and do not have "horns." | [Blade Offset] No change |
| |  | The corners are rounded. | Increase |
| |  | The corners have "horns." | Reduce |

4. Enter the value for the area to be changed.

For information on adjusting the amount of blade extension, refer to "Adjusting the Amount of Blade Extension."

[P. 31 Adjusting the Amount of Blade Extension](#)

| Cutting condition | Setting details | Default setting |
|-----------------------|--|----------------------|
| [Blade Force] | Set the force (pressure) of the blade. | 50 gf (0.11 lbf) |
| [Cutting Speed] | Set the speed of cutting. | 15 cm/s (5.91 in./s) |
| [Blade Offset] | Set the blade offset. Enter the listed offset value for the blade. The offset value for the included blade is 0.250 mm (9.8 mil). | 0.250 mm (9.84 mil) |
| [Rise Movement Speed] | Set the blade's up speed during cutting (the speed at which the blade travels when it moves to the next cutting line after cutting one cutting line). If the media comes loose during no-load feed and the blade damages the surface of the media, reduce the speed. | 15 cm/s (5.91 in./s) |

5. Click [Apply].

6. Continue adjusting the cutting conditions until the settings are optimized.

Repeat Steps 2 to 5 to adjust the conditions.

Once adjustment is complete, click [OK].

This completes the initial adjustment. Start operation according to the user's manual.

RELATED LINKS

- [BY2-20 User's Manual](#)

