

BY2-20

Machine Installation

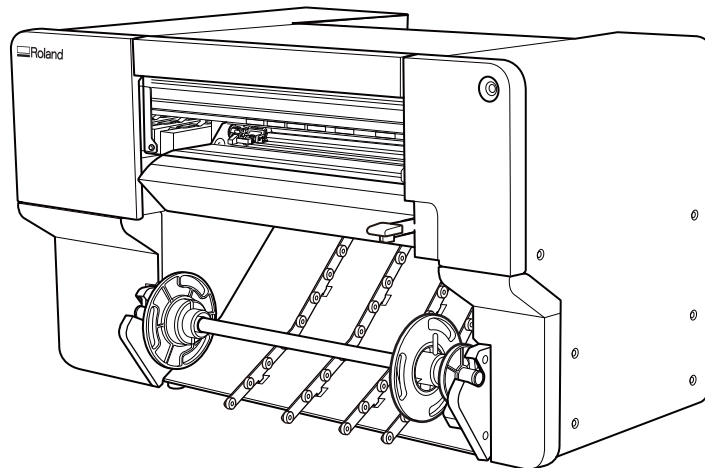

Thank you very much for purchasing this product.

- To ensure correct and safe usage with a full understanding of this product's performance, please be sure to read through this guide completely.
- The specifications of this product and the contents of this guide are subject to change without notice.
- The guide and the product have been prepared and tested as much as possible. If you find any misprints or errors, please inform us.
- Roland DG Corporation assumes no responsibility for any direct or indirect loss or damage that may occur through use of this product, regardless of any failure to perform on the part of this product.
- Roland DG Corporation assumes no responsibility for any direct or indirect loss or damage that may occur with respect to any article made using this product.

Copyright © 2026 Roland DG Corporation

<https://www.rolanddg.com/>

R1-260624

Contents

- Before Installation 2
 - Removing the Machine from the Box 3
 - Checking the Included Items 4
 - Temperature and Humidity 5
 - Emplacement and Installation 6

- Installing the Machine 8
 - Installation Space 9
 - Removing the Retainer 10
 - Connecting the Cables 12
 - Location of the Power Rating and Serial Number Label 13
 - Installing the Media Shaft 14
 - Proceeding to Software Installation 16

Before Installation

Removing the Machine from the Box	3
Checking the Included Items.....	4
Temperature and Humidity	5
Emplacement and Installation.....	6

Removing the Machine from the Box

Packaging diagram

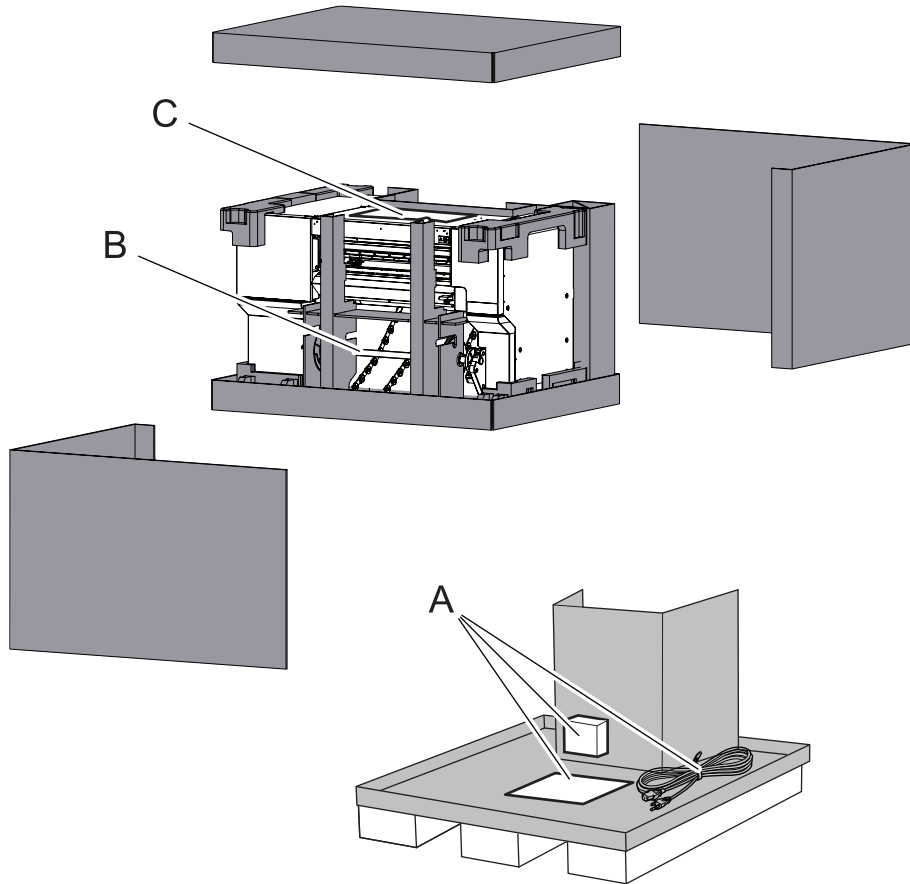

A	Included items (Power cord, blade holder, cleaning liquid, cleaning sticks, etc.)
B	Media shaft
C	Manuals

MEMO



Use the following link to view a reference video for this procedure. We recommend that you view this video to understand the overall flow of work.

<https://vimeo.com/1003476698/0a3b905829>

The BN2-20/20A is shown in this video, but the work and operation procedures are the same for this machine.

Checking the Included Items

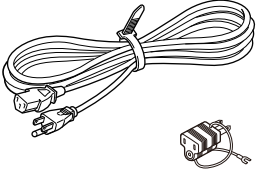
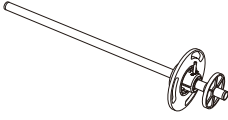
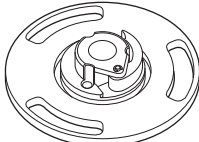
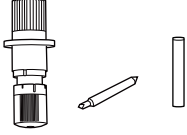
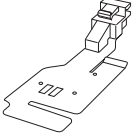
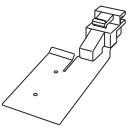
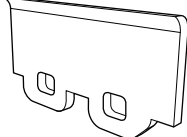
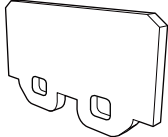
The following items are included with the machine. Make sure they are all present and accounted for.

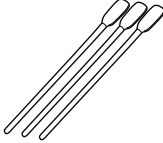
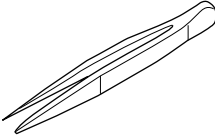
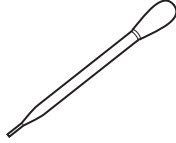
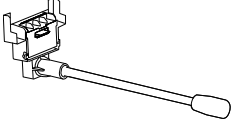
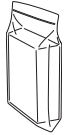
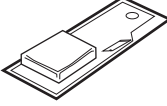
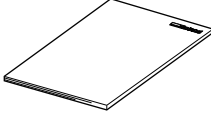
 <p>Power cord/power plug adapter*1 (1 each)</p>	 <p>Media shaft (1)</p>	 <p>Left media flange (1)</p>	 <p>Blade holder/Blade/Pin (1 each)</p>
 <p>Left media clamp *2 (1)</p>	 <p>Right media clamp*2 (1)</p>	 <p>Wiper (1)</p>	 <p>Felt wiper (1)</p>
 <p>S-PG2-CL cleaning liquid (1)</p>	 <p>Cleaning sticks</p>	 <p>Tweezers (1)</p>	 <p>Dropper (1)</p>
 <p>Head nozzle refresher (1)</p>	 <p>Cleaning sheets</p>	 <p>Replacement blades for separating knife</p>	 <p>Manuals</p>

*1 Included only with 100 V specifications

*2 Installed on the machine.

Temperature and Humidity

Maintain the specified temperature and humidity even when the machine is not in use. Failure to do so may result in malfunction.



Temperature

20°C to 28°C (68°F to 82.4°F)

(During non-operation: 5°C to 40°C [41°F to 104°F])



Humidity

40%RH to 60%RH

(During non-operation: 20%RH to 80%RH)

* No condensation

Emplacement and Installation

Install the machine in a level, stable location offering good operating conditions. An unsuitable location can cause accidents, fire, faulty operation, or breakdown.

CAUTION

Install in a level and stable location.

Failure to do so may result in falling of the machine, leading to injury.

Environments or locations where installation is not possible

- Locations subject to large fluctuations in temperature or humidity
- Locations subject to shaking or vibration
- Locations where the floor is tilted, not level, or unstable
- Dusty locations
- Locations exposed to direct sunlight
- Locations near air-conditioning or heating equipment
- Locations exposed to water or moving air
- Locations exposed to considerable electrical or magnetic noise or other forms of electromagnetic energy

CAUTION

Unloading and emplacement are operations that must be performed by 2 persons or more.

Tasks that require undue effort when performed by a small number of persons may result in physical injury. Also, if dropped, such items may cause injury.

WARNING

Install the machine in a location that is level, stable, and able to bear the weight of the machine.

The total weight of the machine may reach 78 kg (172 lb.) or more. Installation in an unsuitable location may cause a major accident, including tip over, fall, or collapse.

WARNING

Never install this machine outside or in any location where exposure to water or high humidity may occur.

Current leakage may cause electrical shock or fire.

WARNING

Never install the machine close to any flammable object or in a gas-filled location.

Combustion or explosion could occur.

WARNING

Position the machine so that the power plug is within immediate reach at all times.

This is to enable quick disconnection of the power plug in the event of an emergency. Install the machine next to an electrical outlet. Also, provide enough empty space to allow immediate access to the electrical outlet.

⚠ CAUTION

Ensure adequate ventilation for the work area.

Failing to perform ventilation may result in a health hazard or danger of combustion due to ink fumes.

⚠ CAUTION

When lifting the machine, hold the locations shown in the figure.

Holding the circled locations, lift the machine and remove it from the box.

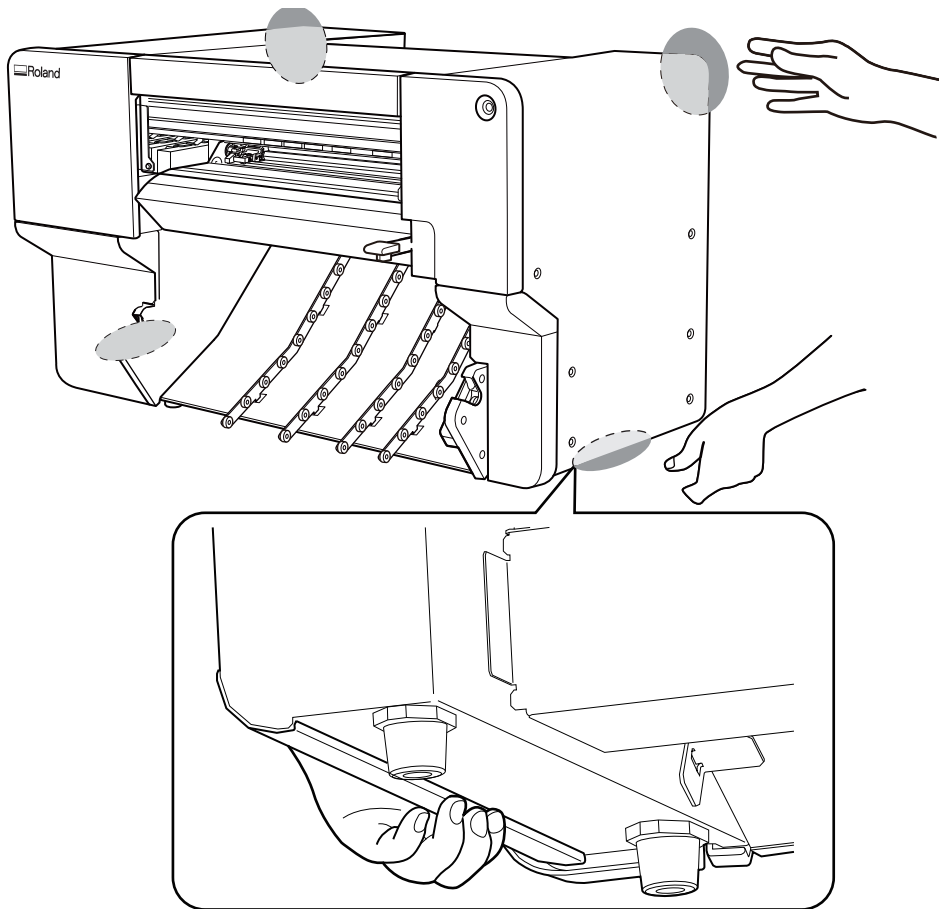

Holding the circled locations, place the machine on the table.

IMPORTANT

- Do not hold the cover on the front of the machine. Doing so may result in faulty operation or breakdown.
- There is a difference in level on the bottom of the machine. Hold the machine by covering this difference in level on the bottom with your finger.

Installing the Machine

Installation Space.....	9
Removing the Retainer.....	10
Connecting the Cables.....	12
Location of the Power Rating and Serial Number Label	13
Installing the Media Shaft	14
Proceeding to Software Installation	16

Installation Space

The space shown in the figure is required in order to use this machine.

IMPORTANT

- This machine is designed to be installed on a desktop. Install the machine so that it is at least 0.6 m (23.6 in.) above the work floor.
- Install the machine in a location that allows easy access to areas such as the power switch and other controls during operation.

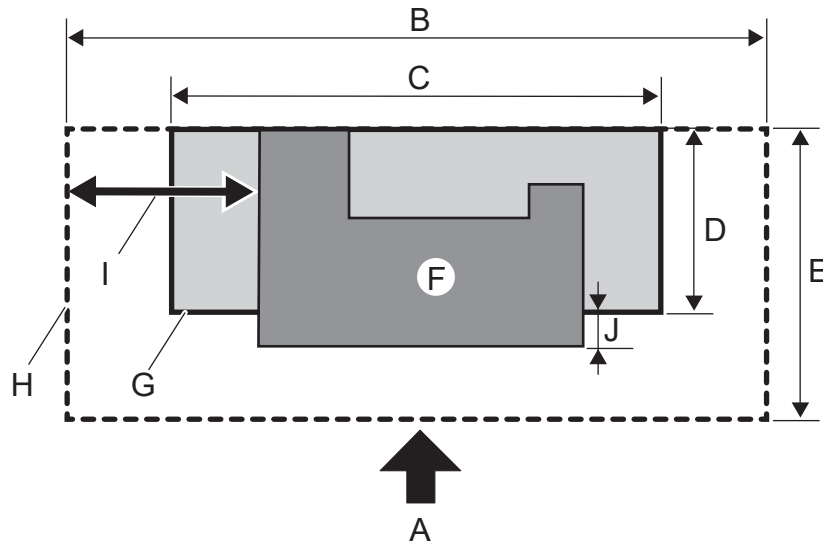

A	Front of machine
B	1,290 mm (50.79 in.)
C	1,085 mm (42.72 in.)
D	670 mm (26.38 in.)
E	1,055 mm (41.5 in.)
F	Unit
G	Recommended table size
H	Work space
I* ¹	220 ml cartridge: 300 mm (11.81 in.) 500 ml cartridge: 600 mm (23.62 in.)
J* ²	120 mm (4.72 in.)

*1 This space is for inserting and removing ink cartridges.

*2 When printing something with a length of 500 mm (19.69 in.) or more, this position prevents the media from contacting the floor of the table.

Removing the Retainer

⚠ WARNING

This work must be performed before connecting the power cord.

The power turning on inadvertently during these operations may result in pinched hands or other injury.

IMPORTANT

Be sure to remove the retainer and screw.

Any that remain may cause faulty operation or breakdown when the power is switched on.

The retainers and screws are needed when transporting the machine. Store them carefully so that you do not lose them.

Open the front cover, remove the tape fixing the media clamp in place, and then remove the retainer and screw.

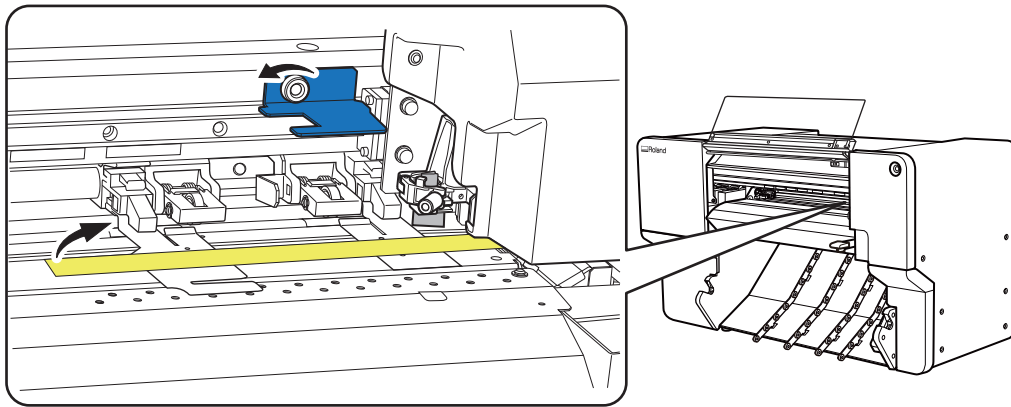

Remove the retainer from the print-head carriage cutting tool attachment part.

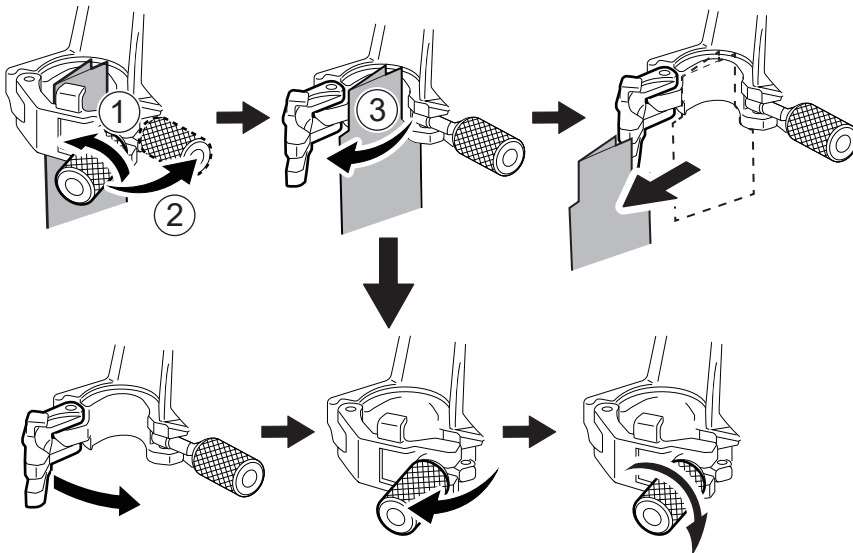

Open the lower-left cover to store the removed retainer and screw.

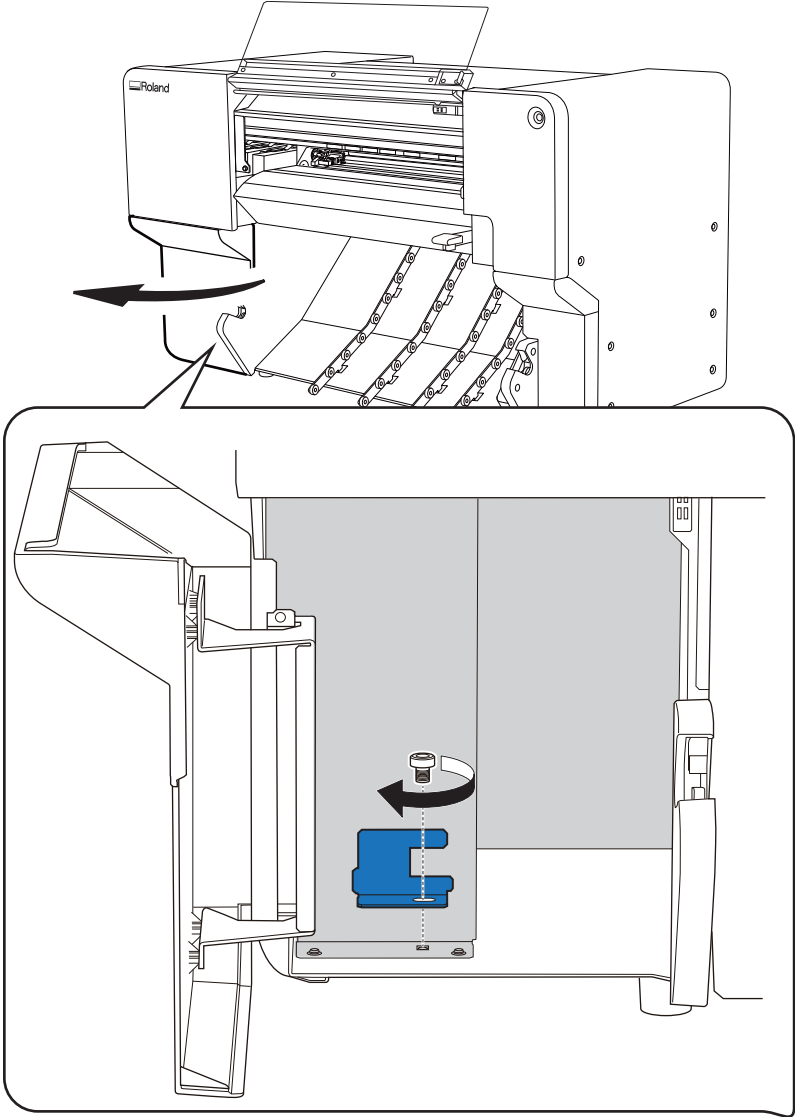

Connecting the Cables

⚠ WARNING

Perform this task with all power switches left switched off.
Otherwise sudden movement of the machine may cause injury.

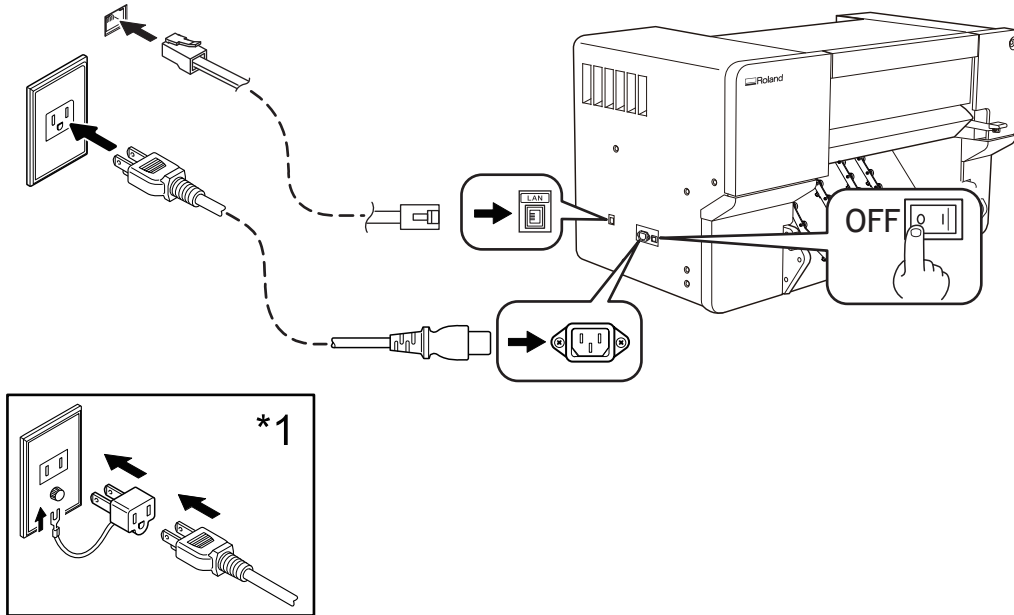

*1: Included only with 100 V specifications

Location of the Power Rating and Serial Number Label

Rear

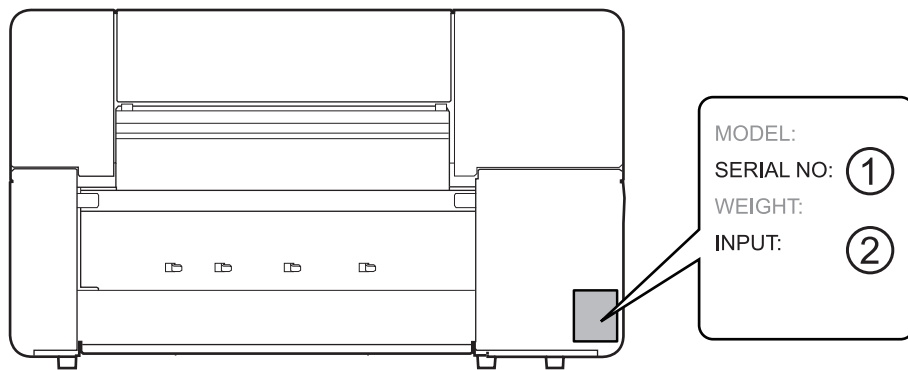

①	Serial number This number is required when you seek maintenance, servicing, or support. Never peel off the label.
②	Power rating Use an electrical outlet that meets the requirements for voltage, frequency, and amperage given here.

Installing the Media Shaft

Procedure

1. Open the lock lever (①) on the left media flange in the direction of the arrow to release the lock.

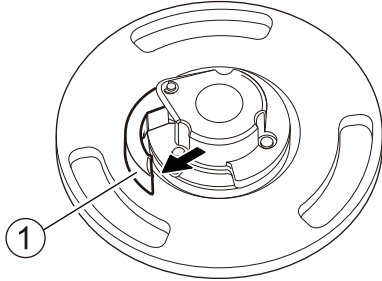

2. Attach the left media flange to the media shaft.

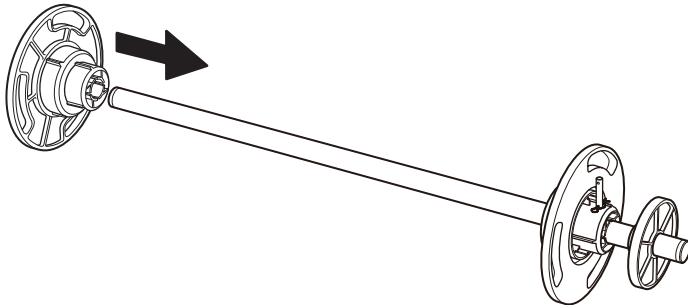

3. Secure the left media flange in place.

Close the lock lever in the direction of the arrow to secure the left media flange in place.

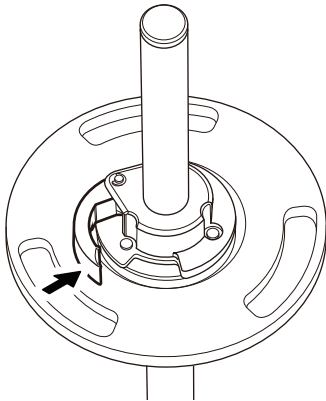

4. Load the media shaft on the printer.
 - a. Align the stopper (①) with the guide (②).
 - b. Press the left and right ends of the media shaft into the shaft holder until you hear a click.

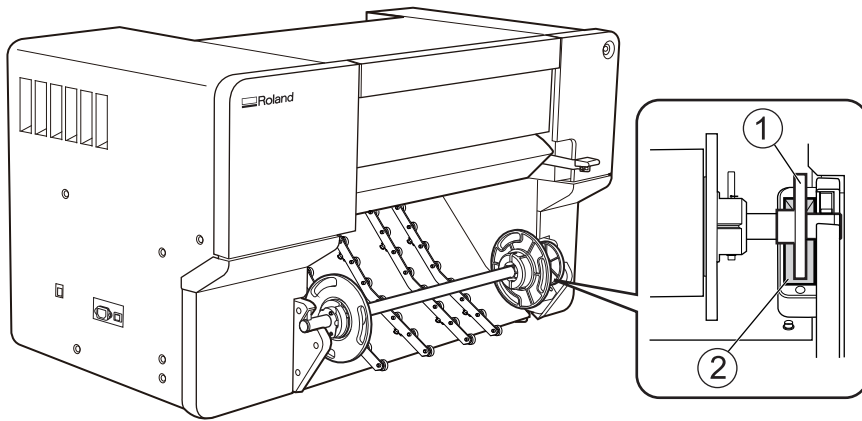

Proceeding to Software Installation

After installing this machine, install the software.

MEMO

The software installation must be performed on a computer.

If you are viewing this manual on your computer

- Click the following URL to check the software installation method.
https://downloadcenter.rolanddg.com/contents/manuals/BY2-20_INS2_EN/index.html

If you are viewing this manual on your mobile device

Use one of the following methods to view the manual on your computer.

- Enter the following URL in your computer's web browser.
https://downloadcenter.rolanddg.com/contents/manuals/BY2-20_INS2_EN/index.html
- If you are viewing this manual in HTML format, click the  icon to start your email software.

Send the URL in an email to an address you can check from your computer.

