

TrueVIS VG4-640/VG4-540

User's Manual

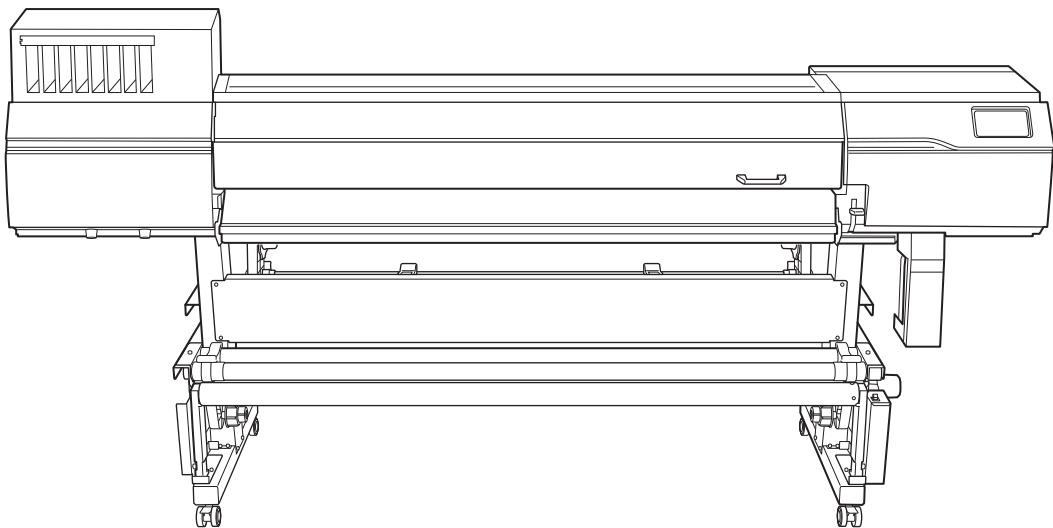

Thank you very much for purchasing this product.

- To ensure correct and safe usage with a full understanding of this product's performance, please be sure to read through this guide completely.
- Unauthorized copying or transferal, in whole or in part, of this guide is prohibited.
- The specifications of this product and the contents of this guide are subject to change without notice.
- The guide and the product have been prepared and tested as much as possible. If you find any misprints or errors, please inform us.
- Roland DG Corporation assumes no responsibility for any direct or indirect loss or damage that may occur through use of this product, regardless of any failure to perform on the part of this product.
- Roland DG Corporation assumes no responsibility for any direct or indirect loss or damage that may occur with respect to any article made using this product.

Contents

Basic Handling Methods	9
Basic Information	10
Part Names and Functions	11
Printer Unit	11
Operation Panel	16
Take-up Unit	23
About the Media Used	24
Types of Media	24
Conditions for Usable Media	25
Take-up Unit	26
Take-up Unit Use Conditions	26
About the Paper Tube	26
Drain Bottle	27
Precautions for Disposing of Discharged Fluid	27
Basic Operations	28
Power Supply Operations	29
Turning the Power On	29
Turning the Power Off	30
Precautions When Operating the Power Supply	31
Sleep Mode (Power-saving Feature)	32
Setup of New Media	33
Setup of Roll Media	33
Setup of Sheet Media	60
Setup of Registered Media	77
Setup of Roll Media	77
Setup of Sheet Media	103
Checking before Output	119
LAN (Local Area Network) Settings	119
Pausing and Canceling Output	120
Pausing and Resuming Output	120
Canceling Output	121
Separating the Media	122
Removing Media from the Take-up Unit	125
Replacing Ink Cartridges	128
Out-of-ink Warnings	128
Preventing Sedimentation in Inks	129
Cleaning Liquid Pouch Replacement	130
Out-of-cleaning-liquid Warnings	130
Cleaning Liquid Pouch Replacement	130
Output Method	133
Printing Method	134
Preparations for Printing Output	135
Step 1: Performing a Printing Test	135
Step 2: Performing Normal Cleaning	137
Starting Output	138
Cutting Method	140
Preparations for Cutting Output	141
Step 1: Switching Off the Print Heater and Dryer	141
Step 2: Preventing Pulling of the Media with Undue Force	142
Step 3: Adjusting Cutting	143

Starting Output.....	145
Printing and Cutting Method.....	147
Preparations before Printing and Cutting Output.....	148
Step 1: Performing a Printing Test	148
Step 2: Performing Normal Cleaning.....	150
Step 3: Adjusting Cutting.....	151
Step 4: Correcting the Misalignment of Printing and Cutting	153
Starting Output.....	155
How to Cut with Crop Marks.....	157
Preparations before Cutting with Crop Marks	158
Step 1: Performing a Printing Test	158
Step 2: Performing Normal Cleaning.....	160
Step 3: Adjusting Cutting.....	161
Step 4: Correct the misalignment of printing and cutting with crop marks at the same time.	163
Starting Printing Output with Crop Marks	165
Preparations for Cutting Output.....	168
Step 1: Setting Up Media with Crop Marks.....	168
Step 2: Switching Off the Print Heater and Dryer	169
Step 3: Preventing Pulling of the Media with Undue Force	170
Starting Cutting Output.....	171
Optimizing Quality and Efficiency	173
Optimizing the Output Quality	174
Using the Correction Functions	175
Automatically Making Required Adjustments	175
Manual Adjustment: Reducing Horizontal Bands (Feed Correction)	176
Manual Adjustment: Adjusting the Misalignment of the Ink Landing Position (Media Gap Adjustment)	178
Configuring Settings to Match the Properties of the Media	180
Changing the Print Head Height.....	180
Using Hard-to-Dry Media	182
Using Media That Wrinkles Easily/Does Not Move Smoothly	183
Using Sticky Media.....	184
Take-up Unit Settings	185
Setting the Take-up Unit	185
Preventing Misaligned Media	187
Use Middle Pinch Rollers When Pulling Back or Feeding Media.....	187
Adjusting the Ink-drying Method	188
What Is the Media Heating System?.....	188
Setting the Print Heater Temperature	190
Setting the Dryer Temperature.....	192
Hints and Tips for Temperature Control	194
Setting the Temperature during Standby	195
Drying the Trailing Edge of the Printing Area on the Dryer	196
Switching Off the Print Heater and Dryer Together	197
Using an Auxiliary Drying Unit (DU3)	199
Accurately Adjusting the Cutting Settings	200
Fine-tuning the Cutting Conditions	200
Adjusting the Amount of Blade Extension	202
Performing Distance Correction during Cutting.....	204
Cutting to Make It Possible to Cut Corners Attractively (Over Cut)	205
Prioritizing the Cutting Settings of This Machine over the RIP Software Settings	206
Accurately Adjusting the Settings for Printing and Cutting	207
Correcting the Misalignment of Printing and Cutting	207
Correcting the Misalignment of the Printing and Cutting Positions during Cutting.....	210
Accurately Adjusting the Settings for Cutting with Crop Marks	212

Correcting the Misalignment of Printing and Cutting with Crop Marks (Concurrent Test for Printing and Cutting with Crop Marks)	212
Correcting the Misalignment of Printing and Cutting with Crop Marks (Separate Test for Printing and Cutting with Crop Marks)	215
Correcting the Reading Sensor	220
Optimizing Work Efficiency	221
Batch Settings for Output	222
Step 1: Configuring [Batch Media Settings]	222
Step 2: Setting the Heater Temperature	223
Step 3: Changing the Print Head Height	224
Step 4: Setting the Media Suction Force	226
Step 5: Configuring Media Sticking Prevention Settings	227
Step 6: Use Middle Pinch Rollers When Pulling Back or Feeding Media	228
Step 7: Adjusting the Output-start Location	229
Step 8: Performing a Printing Test	231
Step 9: Performing Feed Correction (Reducing Horizontal Stripes)	233
Step 10: Adjusting the Misalignment of the Ink Landing Position	235
Step 11: Configuring the Settings to Dry the Trailing Edge of the Printing Area	237
Step 12: Setting the Ink Drying Time	238
Step 13: Fine-tuning the Cutting Conditions	239
Step 14: Correcting the Reading Sensor	241
Step 15: Correcting the Misalignment of Printing and Cutting	242
Step 16: Correcting the Misalignment of Printing and Cutting with Crop Marks (Concurrent Test for Printing and Cutting with Crop Marks)	244
Step 17: Correcting the Misalignment of Printing and Cutting with Crop Marks (Separate Test for Printing and Cutting with Crop Marks)	246
Step 18: Cutting to Make It Possible to Cut Corners Attractively (Over Cut)	250
Step 19: Setting the Printing Movement Range	251
Managing the Media Settings	252
Changing the Media Settings	252
Checking the Registered Media Settings	254
Changing the Media Name	256
Duplicating Media Settings	257
Duplicating Media Settings for Cutting	258
Deleting Media Settings	259
Adjusting the Output-start Location	260
Setting the Base Point	260
Reducing Output Time	262
Speeding Up Output for Narrow Media	262
Printing with Crop Marks	263
Managing VersaWorks Jobs	264
Outputting a Job	264
Displaying the [Printing Log]	265
Other Useful Functions	266
Performing Printing Tests Arranged Horizontally	266
Changing the Operation Panel Color Theme	267
Displaying the 2D Code for Viewing the Manual on the Operation Panel	268
Displaying the Roland DG Connect 2D Code on the Operation Panel	269
Optimizing Operation Management	270
Managing the Operations Appropriately and Efficiently	271
Sounding a Buzzer to Notify the User of the End of Printing	271
Setting the Current Date/Time and Using It for Maintenance	272
Checking the Remaining Media	273
Printing the Amount of Remaining Media	274
Showing/Hiding Notifications	275
Determining What Happens When Ink Runs Out	276
Setting the Activation Interval for Sleep Mode (Power-saving Feature)	277

Setting the Duration of the Warning Beep	278
Managing the Basic Settings of the Printer	279
Set the display language	279
Changing the Units of Measurement	280
Viewing Printer Information	281
Viewing Network Information	282
Adjusting the Brightness of the Operation Panel	283
Turning Off Operation Panel Sounds	284
Returning All Settings to Factory Defaults	285

Maintenance286

Introduction	287
Important Notes on Handling and Use	288
Printer	288
Ink Cartridges	288
Basic Maintenance Knowledge	290
Types and Timing of Maintenance	290
Automatic Maintenance Feature and Notes	292
Measures When the Printer Is Not in Use for a Prolonged Period	294
Regular Maintenance	295
Print Head Check before Printing	296
Performing a Printing Test	296
Cleaning the Machine	298
Cleaning the Media Path	298
Cleaning the Cutting Carriage Roller	299
Cleaning around the Print Heads	300
Manual Cleaning Method	301
Consumable Products and Parts Related to Manual Cleaning	312
Disposing of Discharged Fluid	313
Precautions for Disposing of Discharged Fluid	314
If the Discharged Fluid Disposal Message Appears	315
Advanced Maintenance	317
When Dot Drop-out or Dot Displacement Occurs	318
Normal Cleaning Method	318
When Normal Cleaning Is Not Effective	320
Medium Cleaning Method	320
Powerful Cleaning Method	322
If Colors Are Uneven	324
Light Choke Cleaning Method	324
Ink Circulating Method	326
Handling Severe Dot Drop-out and Dot Displacement	327
Ink Renewal Method	327
Partially Restricting the Print Heads Used for Printing	330
Emergency Measure) Cleaning the Print Head Surface	332
When the Operation Panel Is Dirty	335
Operation Panel Cleaning Method	335
Replacing Consumable Parts	336
Replacing Parts for Maintenance	337
Replacing the Wiper	337
Replacing the Wiper Cleaner	340
Replacing the Print Head Caps	342
Replacing the Flushing Sponges	344
Replacing the Blade/Separating Knife	346

Replacing the Blade	346
Replacing the Separating Knife.....	352
Inquiries for Consumable Parts and Products.....	354
Items That You Can Purchase or Perform by Yourself	354
Items That Require Inquiries before Replacement	354

Troubleshooting Methods.....355

Output Quality Problems.....356

Printed results are coarse or contain horizontal stripes	357
Do the print heads cause dot drop-out?.....	357
Is the print head height appropriate?	357
Have you carried out [Feed Correction]?	357
Have you carried out [Media Gap Adjustment] (ink landing position correction)?	357
Is the printer installed in a level and stable location?.....	358
Is the printer installed in a location that is not exposed to direct sunlight?.....	358
Is the media heating system at a suitable temperature?.....	358
Is the temperature of the room too low?	358
Is the Print Mode Suitable?.....	358
Is the media loaded correctly?	358
Are the [Media Settings] appropriate?.....	358

The media becomes soiled when printed	360
Do the print heads come into contact with the media?	360
Are the print heads dirty?	360
Are the pinch rollers or the media clamps dirty?.....	360
Is the humidity of the room too low?.....	360

Colors are unstable or uneven	361
Did You Shake the Ink Cartridges before Installing Them?	361
Are colors still uneven after mixing the ink by shaking the ink cartridges?	361
Is the media wrinkled?.....	362
Was printing paused partway through?.....	362
Is the printer installed in a level and stable location?.....	362
Is the media loaded correctly?	362
Are the Operating Parameters Set to Appropriate Values?.....	362
Are the [Media Settings] appropriate?.....	363
Is the printer being used in a location subject to severe changes in the operating environment?	363

Cutting Is Misaligned or Skewed	364
Is the media loaded correctly?	364
Are the settings for the cutting conditions appropriate?.....	364
Is the Cutting Speed in the [Take-up during Cutting] Setting Appropriate?	364
Is the length of output too long?.....	364
Are you using media that exhibits large expansion and contraction?	364
Is the setting for the [Cutting Distance Correction] menu item (under [Cutting Settings]) correct?	364
Are the pinch rollers placed on the proper locations?.....	365
Have you corrected the misalignment of printing and cutting?	365
Is the blade holder installed appropriately?.....	365
Is the blade worn?	365
Is There Any Buildup of Pieces of Material or Dust Inside the Blade Holder?	365

Problems in Cutting with Crop Marks367

Automatic Detection of Crop Marks Fails	368
Are the margins from the pinch rollers to the crop marks too small?.....	368
Is the media wrinkled or warped?	368
Is the media size too large?	368
Are you using media that is likely to reflect light or has deep colors?.....	368
Are you using transparent media?	368
Printing and Cutting Are Misaligned.....	369
Have you corrected the misalignment of printing and cutting with crop marks?	369

Media Feed Problems	370
Media Wrinkles or Shrinks	371
Is the media loaded and set up straight and securely?	371
Was loaded media allowed to stand for some time?	371
Was the media loaded while the print heater and dryer were hot?	371
Is the temperature of the room too low?	371
Is the humidity of the room too high?	371
Is the media sagging?	371
Are the media heating system temperatures too high?	371
Media Feeding Is Not Straight	372
Is the media loaded and set up straight and securely?	372
Media Feeding Is Not Smooth	373
Is some other object coming into contact with the media?	373
Is the media too thick?	373
Are the grit rollers dirty?	373
A Media Jam Occurs!	374
Is an error message displayed?	374
Is the media warped or wrinkled?	374
Is the height of the print heads too low?	374
Are the grit rollers dirty?	374
Are the media clamps installed?	374
Is the media loaded and set up straight and securely?	374
Is some other object coming into contact with the media?	375
Is the media too thick?	375
Machine Problems	376
The Printer Cannot Be Started Due to Low Temperature	377
Setting the Print Heater Temperature at Startup	377
Why Has the Print-Head Carriage Stopped Moving?	378
What to Do First	378
If the Print Heads Still Do Not Move	378
The printer unit does not run	380
Is the power switched on?	380
Is [Output possible.] displayed?	380
Are any covers open?	380
Is a message displayed on the screen?	380
Are the cables connected?	380
Is the LAN routing appropriate?	380
Are the LAN settings correct?	381
Did the RIP Software End Abnormally?	381
Is an [Ink Cartridge Error] displayed?	381
Is the message [Output is currently paused.] displayed on the screen?	382
The Media Heating System Doesn't Warm Up	383
Has the media been set up?	383
Is [Heater Power] turned on?	383
Is the temperature of the room too low?	383
Cannot Separate the Media	384
Is the separating knife installed?	384
Messages on the Operation Panel	385
Messages	387
[When output, cleaning, and other operations are completed, discard the]	387
[The time for manual cleaning has arrived.]	387
[Maintenance must be performed.Perform manual cleaning.]	387
[The time for wiper replacement has arrived.]	387
[The time for wiper cleaner replacement has arrived.]	388
[The time for cap replacement has arrived.]	388
[The time for flushing sponge replacement has arrived.]	388

[Print head protection mode has activated.]	388
[Replace the cleaning liquid pouch.]	388
[Install the cleaning liquid pouch.]	389
[The extended dryer is not connected.]	389
[The time for ink mixing has arrived.]	389
[Operation of the take-up unit stopped.]	389
[Place the middle pinch rollers over all the grit rollers.]	390
[Install the media clamps correctly.]	390
[Media clamps could not be detected.]	390
[The LAN cable is not connected.]	391
[The media could not be detected automatically.Manually set the printing]	391
[Turn on the power. Cleaning will start.]	391
Error Messages.....	392
[Ink Cartridge Error]	392
[Cover Open Error]	392
[Media End Error]	392
[Take-up Unit Setup Error]	392
[Pinch Lever Error]	393
[Media Loading Error]	393
[Drain Bottle Error]	393
[Crop Mark Detection Error]	393
[Unable to Fill Wiper Cleaning Liquid]	394
[Pinch Roller Error]	394
[Maintenance Cleaning]	394
[Print Head Height Mismatch]	395
[Insufficient Media Width]	395
[Printing Size Error]	395
[Motor Error]	395
[Print Head Dry-out Error]	396
[Low Temperature Error]	396
[High Temperature Error].....	396
[Pump Stop Error]	396
[Cleaning Error (Ink Cartridge)]	397
[ConnectHub Communication Error].....	397
[Barcode scanning error]	397
[Take-up Unit Communication Error]	397
[Service Call]	398
[Cleaning Error (Drain Bottle)].....	398
[Print Head Error]	398
[Software error]	398
[Communication with Roland DG Connect Hub was not possible.]	398
[Failed to connect to VersaWorks.]	399
[Printing could not start.]	399

Appendix.....400

Operations When Moving the Unit	401
Preparing to Move the Machine	402
Step 1: Removing Media and the Blade Holder.....	402
Step 2: Circulating the Ink (Only When Using White Ink).....	404
Step 3: Discarding the Discharged Fluid	405
Step 4: Securing the Print-head Carriage in Place Using the Retainer	407
Step 5: Reinstalling the Machine	409
Main Specifications	411
Printing/Cutting Area	412
Maximum Area	412
Maximum Printing Area When Using Crop Marks.....	413
Media Separation Location during Continuous Printing.....	414

Contents

About the Blade 415
Specifications..... 416
Memo.....417
Software..... 418

Basic Handling Methods

Basic Information

Part Names and Functions.....	11
Printer Unit.....	11
Operation Panel	16
Take-up Unit	23
About the Media Used	24
Types of Media	24
Conditions for Usable Media	25
Take-up Unit.....	26
Take-up Unit Use Conditions.....	26
About the Paper Tube.....	26
Drain Bottle	27
Precautions for Disposing of Discharged Fluid	27

Part Names and Functions

Printer Unit

Front

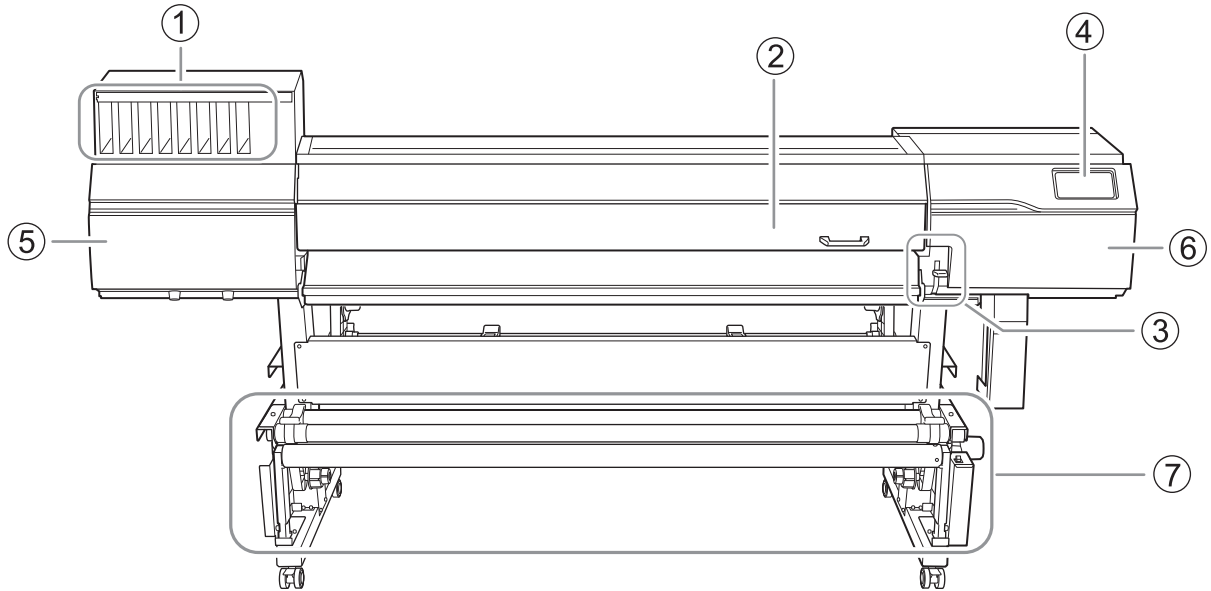

No.	Name	Function overview
①	Cartridge slots	The location where ink cartridges are installed.
②	Front cover	Open this when necessary, such as when loading media. Keep this cover closed when not loading media or performing maintenance.
③	Loading lever (front)	Secures the media in place and releases it. Use this lever when working at the front of the machine. Lowering the lever secures the media in place.
④	Operation panel	The panel containing the buttons used to operate the machine. P. 16 Operation Panel
⑤	Left cover	Open this when you perform maintenance.
⑥	Right cover	Open this when you perform maintenance.
⑦	Take-up Unit	Takes up the media after printing. This prevents the printed media from touching the floor.

Rear

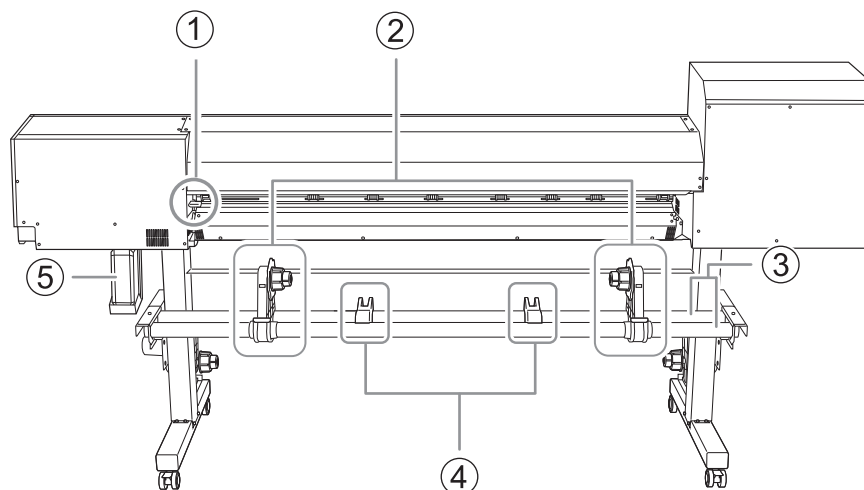

No.	Name	Function overview
①	Loading lever (rear)	Secures the media in place and releases it. Use this when working behind the machine. Lowering the lever secures the media in place.
②	Media holders	Use these when you load media.
③	Shafts	
④	Media stays	
⑤	Drain bottle	Discharged fluid is stored in this bottle. When discharged fluid is nearly overflowing from the bottle, an error is displayed and printing is not possible.

Side

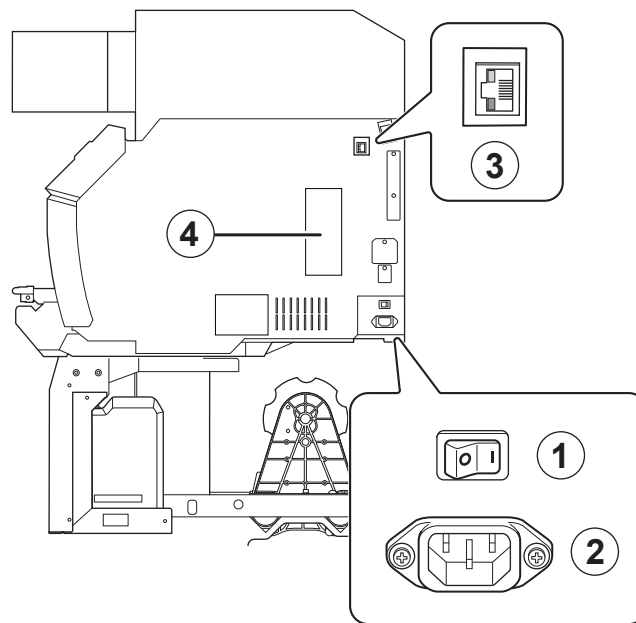

No.	Name	Function overview
①	Main power switch	Switches the main power of the machine on/off.
②	Power-cord connector	Used to connect the power cable from which power is supplied to the machine.
③	Ethernet connector	Connects an Ethernet cable.
④	Cleaning cartridge slot	This is the location where the cleaning cartridge is installed.

Front Cover Interior/Print Head Carriage Area

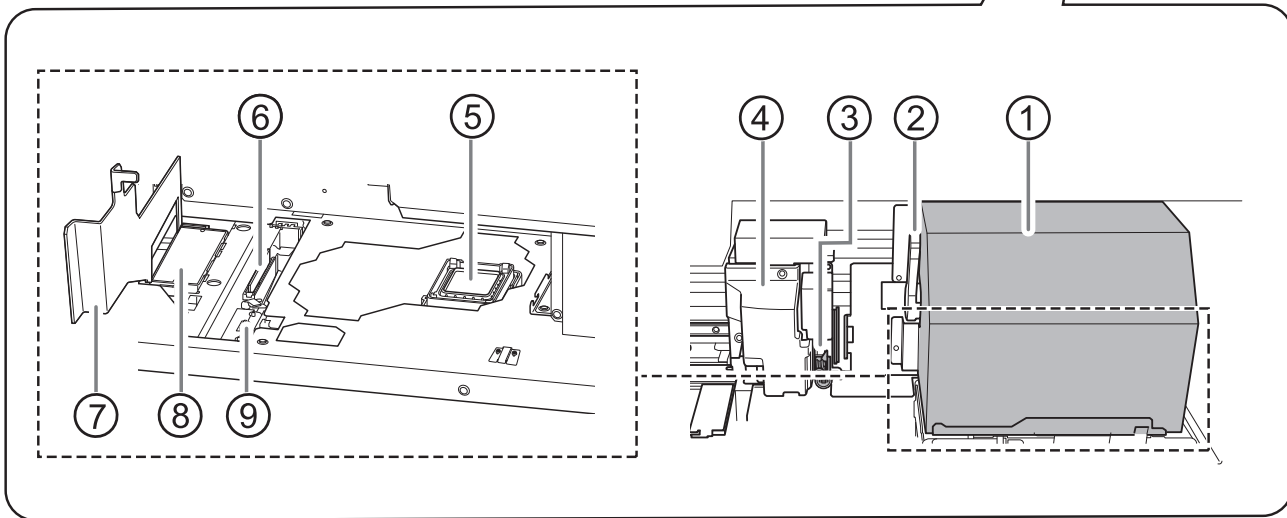
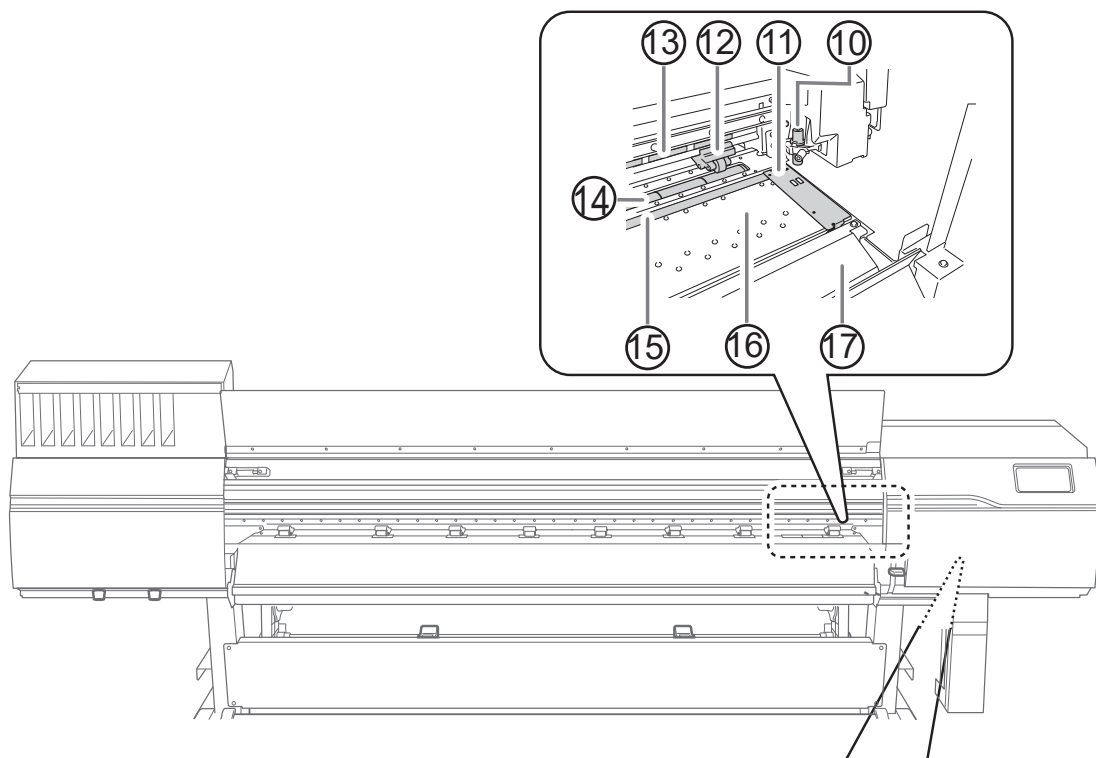

No.	Name	Function overview
①	Print-head carriage	Transports the built-in print heads.
②	Height-adjustment lever	You can adjust the print-head height.
③	Separating knife	This separates the media.
④	Cutting carriage	The blade and the separating knife are inside here.
⑤	Print head cap	Prevent the print heads from drying out. Seals to the print heads to protect the ink emission surface when the print heads are at the right side of the machine, such as when waiting for printing.
⑥	Wiper	Cleans the print heads. Removes dirt and excess ink that have adhered to these heads.

No.	Name	Function overview
⑦	Flushing cover	Prevents the flushing sponge from coming off. Open the flushing cover when performing the following work. Keep the flushing cover closed except when performing this operation. <ul style="list-style-type: none"> • Cleaning around the print heads • Replacing the flushing sponges • Replacing the wiper cleaner
⑧	Flushing sponge	Absorbs the ink being discharged (flushed) to prevent clogging.
⑨	Wiper cleaner	Removes ink and dirt that have adhered to the wiper.
⑩	Blade holder	Houses the blade used during cutting.
⑪	Media clamp	Clamps the left and right edges of the media. Each clamp holds down the left or right edge of the media, keeping the media from coming loose and preventing fuzz on the cut edge of the media from touching the print heads.
⑫	Pinch roller	Clamps the media together with the grit roller for transporting. The roller can be raised or lowered by moving the loading lever up or down.
⑬	Grit pattern	Indicates the location of a grit roller. When loading media, be sure to place the pinch rollers within the ranges indicated by these patterns.
⑭	Grit roller	Transports the media.
⑮	Blade protector	Protects the cutter blade as it penetrates the media during cutout.
⑯	Platen	This is the path over which the media passes. The platen has a built-in suction fan and heater (print heater) that keep the media from coming loose.
⑰	Apron	This is the path over which the media passes. The apron contains a heater (dryer) to accelerate ink drying.

If a Cover Opens during Operation

IMPORTANT

Even if the front cover, left cover, or right cover (hereinafter these items are all referred to as the "cover") opens during an output operation, the print-head carriage may still move slowly. Exercise caution.

Operation Panel

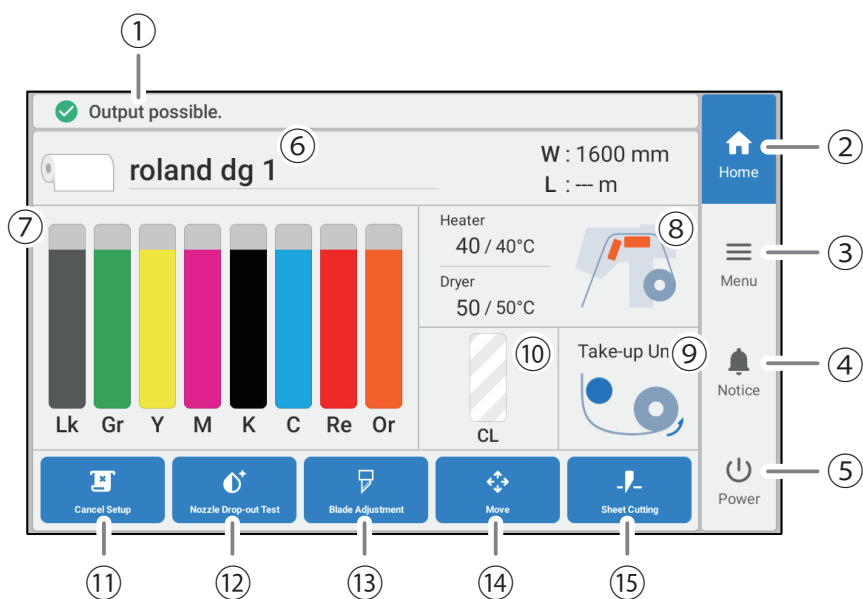

No.	Name	Details
①	Status bar	Displays the printer status and indicates the next operation.
②	Home	Displays the home screen.
③	Menu	Displays various setting menus.
④	Notifications	Displays important information. When there are notifications, their number is displayed next to the icon.
⑤	Sub power	Switches the sub power of the machine on/off.
⑥	Media information	Displays the media name and media width (W) for media that has been set up. If the remaining media setting has been configured, the remaining media (L) is also displayed. Tap the media width (W) or the remaining media (L) to display the [Remaining Media Management] screen on which you can set the remaining media. P. 273 Checking the Remaining Media
⑦	Amount of ink remaining	Displays the amount of ink remaining in each ink cartridge. If it is time to replace an ink cartridge, is displayed next to the corresponding cartridge. Tap this icon to display the detailed information for the ink.
⑧	Heater Temperature	The print heater and dryer temperatures are displayed as current temperature/set temperature. Tapping one of these items displays a screen for the following settings. <ul style="list-style-type: none"> When media is set up <ul style="list-style-type: none"> Turning [Heater Power] on/off. Turning [Print Heater] on/off and setting its temperature. Turning [Dryer] on/off and setting its temperature. When no media is set up <ul style="list-style-type: none"> Turning [Standby Heater Temperature] on/off and setting its temperature.
⑨	Take-up Unit	Displays the status of the take-up unit. Tap this icon to display the [Take-up] screen and set [Take-up during Cutting], [Take-up Method], and [Take-up Direction].
⑩	Amount of cleaning liquid remaining	Displays the amount of cleaning liquid remaining. When the time for replacement arrives, is displayed.

No.	Name	Details
⑪	[Setup]/[Cancel Setup]	Starts/cancels the setting up of the media. P. 33 Setup of New Media P. 77 Setup of Registered Media
⑫	[Cleaning]/[Nozzle Drop-out Test]	Displays the menu related to the printing test and cleaning for the nozzle drop-out check.
⑬	[Blade Adjustment]	Sets cutting conditions. This is only enabled when media has been set up.
⑭	[Move]	The media can be fed and the cutting carriage can be moved. You can also set the position moved to as the right edge of the printing area (the base point). P. 260 Adjusting the Output-start Location
⑮	[Sheet Cutting]	Activates the separating knife to separate the media. You can also perforate the media to take it up and separate it at a later time. This is only enabled when media has been set up. Media margins can also be adjusted after separating the media and cutting perforated lines. P. 122 Separating the Media

MEMO

The following are displayed during printing.

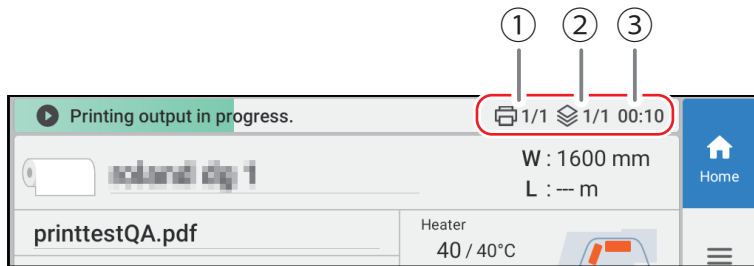

No.	Name	Details
①	Copies to Print	*/* is displayed. The left side indicates the number of the copy currently being printed. The right side indicates the total number of copies.
②	Number of Layers	*/* is displayed. The left side indicates which number layer is currently being printed. The right side indicates the total number of layers.
③	Print Time	Displays the remaining print time (approximate).

Menu List

Tap  to display the list of operations.

MEMO

[Media Settings] only appears when media has been set up. When [Menu operation in progress: Press [Home] to enable output.] is displayed in the status bar, the display will automatically return to the home screen after 5 minutes.

Level 1	Level 2	Level 3	Level 4	Details	
[Job Management]	[Direct Printing]			Perform [VersaWorks] and [Queue Folder] via Roland DG Connect Hub, and then output the job.	
	[Printing Log]			Displays the job [Printing Log]. The [Job Properties] and for each job, and the [Total Time] and [Total Area] for all jobs, can be checked.	
[Media Settings] ^{*1}	[List of Media Settings]			Lists the settings of the media that has been set up. Tap a setting to move to a screen for changing this setting.	
	[Printing Settings]	[Print Head Height]			Checks/changes the print head height.
		[Batch Automatic Correction]			Adjustments are performed in the following order: [Multi Sensor Adjustment], [Feed Correction], then [Media Gap Adjustment].
		[Feed Correction]	[Simple Correction (Auto)]		Adjusts the media feed amount during printing. With [Simple Correction (Auto)], a printed test pattern is read with a sensor to automatically set correction values.
			[Detailed Correction (Manual)]		Adjusts the media feed amount during printing. With [Detailed Correction (Manual)], the printed test pattern must be checked visually and the correction values entered manually.
		[Media Gap Adjustment]	[Simple Correction (Auto)]		Corrects the ink landing position. With [Simple Correction (Auto)], a printed test pattern is read with a sensor to automatically set correction values.
			[Detailed Correction (Manual)]		Corrects the ink landing position. With [Detailed Correction (Manual)], the printed test pattern must be checked visually and the correction values entered manually.
	[Cutting Settings]	[Blade Adjustment]			Sets cutting conditions such as [Blade Force] and [Cutting Speed].
		[Print & Cut Position Adjustment]			Corrects misalignment in the printing position and the cutting position during printing and cutting.
		[Crop Cut Position Adjustment]			Corrects misalignment in the crop mark positions and the cutting position when cutting with crop marks.
		[Cutting Distance Correction]			Corrects misalignment in the cutting line length due to changes in the media movement distance.
		[Over Cut]			Cutting the corners of the border of the cutting line slightly longer makes it possible to cut the corners attractively.
	[Heater Settings]	[Heater Temperature]	[Heater Power]		Switches the print heater and dryer on/off together. Switch these off in situations such as cutting that does not require the media heating system.
			[Print Heater]		Switches the print heater on/off and changes the set temperature.
			[Dryer]		Switches the dryer on/off and changes the set temperature.
[Dry After Printing]			Sets whether to send printed media to the dryer and what drying settings to use. The drying time can also be set.		

Level 1	Level 2	Level 3	Level 4	Details
	[Other Media Settings]	[Multi Sensor Adjustment]		Optimizes the status of the multi sensor used when reading the media width and with the automatic correction function.
		[Drying Time Per Scan]		Sets the drying time per scan operation of the print-head carriage.
		[Media Suction Force]		Adjusts the media suction force to prevent the media from coming loose or sticking.
		[Printing Movement Range]		Sets the print head carriage movement range during printing.
		[Media Sticking Prevention]		Performs media peel-off before printing.
	[Middle Pinch Auto Raise/Lower]		The middle pinch rollers go up automatically during pull-back printing or printing and cutting.	
	[Batch Media Settings]			The minimum settings required for media setup can be configured by following the on-screen instructions on the operation panel.
[Media Management]				<p>Displays a list of registered media. Up to 50 media names can be saved, and the following operations on media settings are possible.</p> <ul style="list-style-type: none"> • Checking setting details in a list • Changing media names • Copying media settings • Duplicate as Media for Cutting • Deleting media settings
[Cleaning]	[Printing Test]			Before printing, use [Nozzle Drop-out Test] to check whether ink is discharged from the print heads correctly. If dot drop-out is present, perform cleaning appropriate for the severity of the drop-out. If faulty ink discharge cannot be improved, the problematic nozzle can be identified with [Nozzle Mask Test], making it possible to stop using this nozzle.
	[Normal Cleaning]			If dot drop-out or dot displacement occurs, clean the print heads. If the problem cannot be fixed, perform more powerful cleaning.
	[Medium Cleaning]			
	[Powerful Cleaning]			If the media has already been set up, the [After cleaning, perform a printing test.] menu appears. When this is turned on, a printing test is performed after cleaning.
[Manual Cleaning]			Use cleaning liquid and a cleaning stick to clean the area around the print heads.	

Part Names and Functions

Level 1	Level 2	Level 3	Level 4	Details
[Maintenance]	[Wiper Replacement]			Replace the wipers.
	[Blade Replacement]			Replaces the blade used in cutting.
	[Separating Knife Replacement]			Replaces the separating knife used in media separation.
	[Cap Replacement]			Replaces the print head caps, which are used to protect the print heads from drying out and from dust.
	[Wiper Cleaner Replacement]			Replaces the wiper cleaner used to wipe away dirt from the wiper.
	[Flushing Sponge Replacement]			Replaces the flushing sponge used to absorb the ink discharged (flushed) to prevent clogging.
	[Ink Renewal]			<p>Perform this operation when ink discharge issues are not resolved after performing the work below.</p> <ul style="list-style-type: none"> • [Normal Cleaning] • [Medium Cleaning] • [Powerful Cleaning] • [Manual Cleaning] <p>Perform this operation when uneven color issues (except for white ink) are not resolved after performing the work below.</p> <ul style="list-style-type: none"> • Ink mixing • [Light Choke Cleaning] <p>Perform this operation when uneven color issues (white ink) are not resolved after performing the work below.</p> <ul style="list-style-type: none"> • Ink mixing • [Ink Circulation] • [Light Choke Cleaning] <p>However, this operation consumes a large amount of ink and may damage the print heads, so do not perform it more than necessary.</p>
	[Ink Circulation] ²			<p>If white ink uneven color is not resolved even after mixing the ink, circulate the ink.</p> <p>If the media has already been set up, the [After cleaning, perform a printing test.] menu appears. When this is turned on, a printing test is performed after [Ink Circulation].</p>
	[Light Choke Cleaning]			<p>Perform this operation when uneven color issues (except for white ink) are not resolved after performing the work below.</p> <ul style="list-style-type: none"> • Ink mixing <p>Perform this operation when uneven color issues (white ink) are not resolved after performing the work below.</p> <ul style="list-style-type: none"> • Ink mixing • [Ink Circulation] <p>However, this operation consumes a large amount of ink and may damage the print heads, so do not perform it more than necessary.</p>
[Drain Bottle]			Use this menu to discard discharged fluid at any desired time, regardless of any notifications or errors.	
[Automatic Maintenance]			Set the maintenance items that are performed automatically and the [Type] and [Frequency] according to the printer service environment, types of products that are frequently output, and other factors. A maximum of five settings for automatic maintenance can be saved.	

Level 1	Level 2	Level 3	Level 4	Details
[Preferences]	[Media Edge Detection]			Sets whether to detect the leading and trailing edges of the media. When using transparent media, whose edges cannot be detected, the media can be set up without detecting the edges by selecting [Disable].
	[Take-up]			Sets the [Take-up during Cutting], [Take-up Method], and [Take-up Direction] for the take-up unit.
	[Remaining Media Management]			Sets the amount of remaining media that has been set up and displays this amount. This amount can also be printed on the media.
	[Extended Dryer]			These settings are required when using an auxiliary drying unit. Set them individually to [Enable] and [Disable].
	[Blower Fan]			
	[Skewing Correction Support at Setup]			Sets whether to use sound and suction fans to assist in the setup process so that the media is not installed at an angle to the feed direction. When using transparent media or other media that the sensor does not work on, set to [Disable].
	[Printing Test Position]			Sets the direction for test pattern printing: [Feed] or [Scan].
	[Perforated Sheet Cutting]			Sets the perforated sheet cutting conditions.
	[Standby Heater Temperature]	[Standby Heater Temperature]		Sets the heater temperature when media has not been set up.
		[Startup Heater Temperature]		Sets the warmup heater temperature if the temperature is low at startup.
	[Prefeeding at Output]			Determines whether to advance the media before output so that when the printer pulls out the media such as for cutting, the media will not be pulled forcibly, causing misalignment or distortion of the cut position.
	[Priority for Cutting Settings]			Sets whether to prioritize the cutting settings of the machine or the RIP software.
	[Ink Empty Mode]			Sets whether printing should continue or stop if the ink runs out during printing.
	[Notifications On/Off]			When this is set to on, notifications are displayed at the appropriate times. <ul style="list-style-type: none"> • [Ink Mixing Notification]² • [Middle Pinch Roller Placement Notification] • [Media Clamp Placement Notification]
	[Sound at End of Printing]			Selects whether to play a sound at the end of printing.
	[Sleep Time]			Sets the time until sleep mode (the state in which the power-saving features operate) activates.
	[Stopping the Warning Beep]			Sets the duration of the warning beep that sounds when, for example, an error occurs.
[Reset to Factory Defaults]			Returns all settings other than [Language] and [Units], including registered media, to their factory default values.	

Part Names and Functions

Level 1	Level 2	Level 3	Level 4	Details
[System Information]	[Machine Information]			Displays the [Model], [Serial Number], [Ink Type], [Firmware Version], and [MAC Address].
	[Network]			Sets the [Obtain IP Address Automatically], [IP Address], [Subnet Mask], and [Default Gateway] to connect the machine to a computer.
	[Units]			Sets the length and temperature units.
	[Language]			Sets the language.
	[Date/Time]			Sets the current year, month, day, hour, minute, and second.
	[Appearance]			Selects the color scheme of the operation panel's screen.
	[Screen Brightness]			Sets the brightness of the operation panel's screen.
	[Screen Operation Sound]			Turns the operation sound of the operation panel on/off.
	[2D Codes]	[User's Manual]		Displays the 2D code for viewing the manual using a smartphone or other mobile terminal.
		[Roland DG Connect]		Displays the 2D code for accessing [Roland DG Connect] using a smartphone or other mobile terminal.
[License]			Displays the software license information.	

*1 This setting only appears when media has been set up.

*2 This menu item is only displayed on machines when the ink type includes white ink.

Take-up Unit

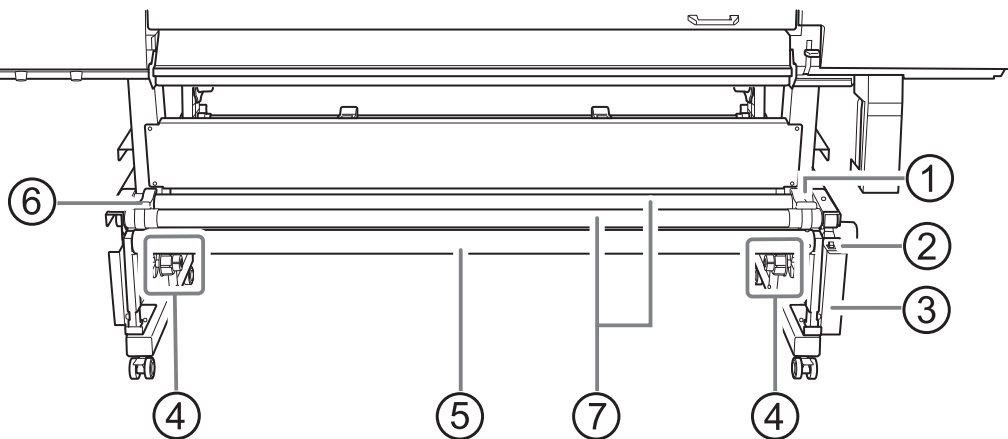

No.	Name	Function overview
①	Motorized media holder	Holds the right side of the paper tube for take-up. Move this part to the right or left to match the width of the paper tube and insert this tube to the appropriate positions on the end caps. The media holder's built-in motor rotates the end caps to take up the media.
②	MANUAL switch	Use this switch when manually taking up the media.
③	Control box	This controls the media take-up.
④	End caps	Hold the paper tube for take-up. Insert this tube to the appropriate positions on the end caps.
⑤	Dancer roller	Adjusts the tension applied to the media to ensure there is no slack in the media and that it is not too tight. Lower this roller to the rear when not using the take-up unit.
⑥	Left media holder	Holds the left side of the paper tube for take-up. Move this part to the right or left to match the width of the paper tube and insert this tube to the appropriate positions on the end caps.
⑦	Shafts	Adjust the position of the media holders. The media holders are moved to the left or right along these shafts to match the width of the media.

About the Media Used

Types of Media

In this manual, the paper used for output is called "media." The two main types of media used in this machine are shown below.

- Roll media: Media wound onto a paper tube
- Sheet media: Media not wound onto a paper tube such as standard-size media

Various paper types of roll media and sheet media are selectable according to your purpose. For detailed information about each media, contact your media supplier.

Conditions for Usable Media

This machine cannot print on every kind of media. When selecting media, be sure to carry out testing in advance to make sure that satisfactory printing results are obtained.

Size

	VG4-640	VG4-540
Width *1	335 to 1,625 mm (13.2 to 64 in.)	295 to 1,371 mm (11.7 to 54 in.)
Thickness*1	Maximum 1.0 mm (39.3 mil) with liner, for printing Maximum 0.4 mm (15.7 mil) with liner and 0.22 mm (8.6 mil) without liner, for cutting	
Maximum roll outer diameter	250 mm (9.84 in.)	
Paper tube (core) inner diameter	76.2 mm (3 in.) or 50.8 mm (2 in.)	

*1 Applies to both roll and sheet media

Maximum Roll Weight

- 64-inch model: 45 kg (99 lb.)
- 54-inch model: 35 kg (77 lb.)

MEMO

If using the take-up unit, this specification depends on the conditions of the take-up unit.

Other Conditions

Media such as the following cannot be used.

- Media whose end is attached to the paper tube (core)
- Media that is severely warped or that has a strong tendency to reroll
- Media whose paper tube (core) is bent or crushed
- Media that bends under its own weight when loaded
- Media on a sagging roll
- Media that is rolled unevenly
- Media that cannot withstand the heat of the media heating system

Take-up Unit

Take-up Unit Use Conditions

Never pull the media with excessive force.

If the media is pulled with excessive force, the protection function will activate and cause an error. Make sure to observe the following to prevent the media from being pulled with excessive force.

- Do not operate the manual switch on the take-up unit while leaving media secured with the loading lever.

It may cause an error because the media is pulled with excessive force.

Never use the automatic separation function for media.

If automatic separation of media is set in the RIP software, the media will be separated after each page is printed. When continually printing and taking up multiple pages, disable the automatic separation function in the RIP software. If the media is separated, take-up will be interrupted at that point.

MEMO

Depending on the RIP software you are using, you can set the perforated sheet cutting in the RIP software. With this type of cutting, the media is not separated, so the take-up unit can be used.

About the Paper Tube

Paper tubes are consumable items.

Paper tubes are components that wear out. Although replacement timing will vary depending on use, watch the condition of the paper tube and replace at an appropriate time so that the media can be taken up in good working order.

Use the paper tube of the media you are using. To purchase the included paper tube, contact your authorized Roland DG Corporation dealer or visit our website (<https://www.rolanddg.co.jp/>).

Drain Bottle

Precautions for Disposing of Discharged Fluid

WARNING

Never place discharged fluid or ink near an open flame.
Doing so may cause a fire.

CAUTION

To store discharged fluid temporarily, place it in the included drain bottle or in a durable sealed container such as a metal can or polyethylene tank, and cap the container tightly.
Any spillage or vapor leakage may cause fire, odor, or physical distress.

IMPORTANT

Dispose of discharged fluid properly, in accordance with the laws in effect in your locale.
Discharged fluid is flammable and contains toxic ingredients. Never attempt to incinerate discharged fluid or discard it with ordinary trash. Also, do not dispose of it in sewer systems, rivers, or streams. Doing so may have an adverse impact on the environment.

IMPORTANT

Do not store discharged fluid in a location where it is exposed to direct sunlight.
When temporarily storing discharged fluid in the included drain bottle, do not store it in a location that is exposed to direct sunlight. The discharged fluid may harden, making the drain bottle unusable. The drain bottle may also deteriorate, leading to discharged fluid leaks.

Basic Operations

Power Supply Operations	29
Turning the Power On	29
Turning the Power Off	30
Precautions When Operating the Power Supply	31
Sleep Mode (Power-saving Feature)	32
Setup of New Media	33
Setup of Roll Media	33
Setup of Sheet Media	60
Setup of Registered Media	77
Setup of Roll Media	77
Setup of Sheet Media	103
Checking before Output	119
LAN (Local Area Network) Settings	119
Pausing and Canceling Output	120
Pausing and Resuming Output	120
Canceling Output	121
Separating the Media	122
Removing Media from the Take-up Unit	125
Replacing Ink Cartridges	128
Out-of-ink Warnings	128
Preventing Sedimentation in Inks	129
Cleaning Liquid Pouch Replacement	130
Out-of-cleaning-liquid Warnings	130
Cleaning Liquid Pouch Replacement	130

Power Supply Operations

Turning the Power On

WARNING

Remove any loaded media or switch off the sub power when printing is not being performed. The continued application of heat at a single location may cause the release of toxic gases from the media or pose a fire hazard.

Procedure

1. Close the front cover.
2. Turn on the main power switch.

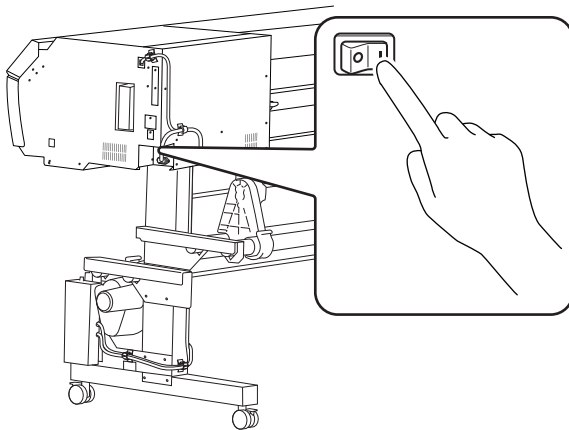

3. Tap the operation panel.

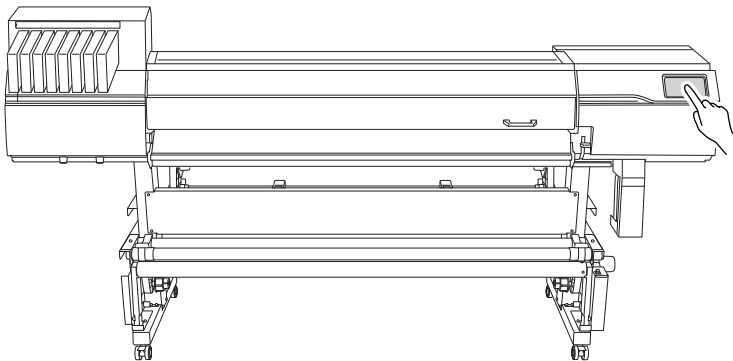

4. When instructions appear on the screen, tap the operation panel again. The machine sub power is switched on.

Turning the Power Off

⚠ WARNING

Remove any loaded media or switch off the sub power when printing is not being performed. The continued application of heat at a single location may cause the release of toxic gases from the media or pose a fire hazard.

Procedure

1. When printing is complete, tap  on the operation panel.
The confirmation screen appears.
2. Tap [Yes].
The machine sub power is switched off.
3. Raise the loading lever and remove the media.
 - When not using the machine, raise the loading lever even if the sub power is on.

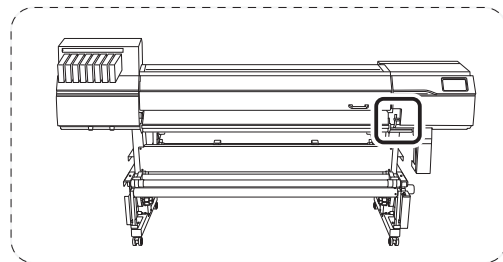
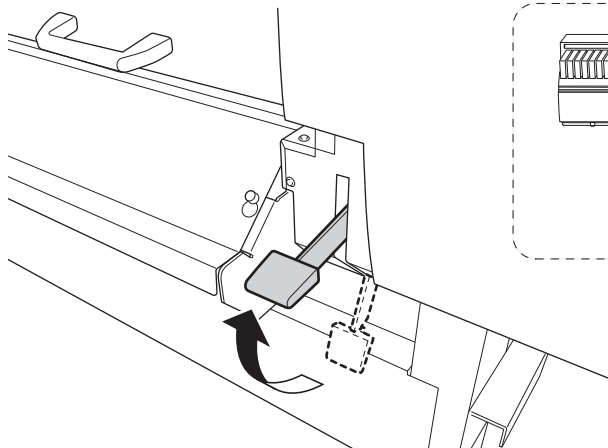

- Lower the dancer roller toward the rear.

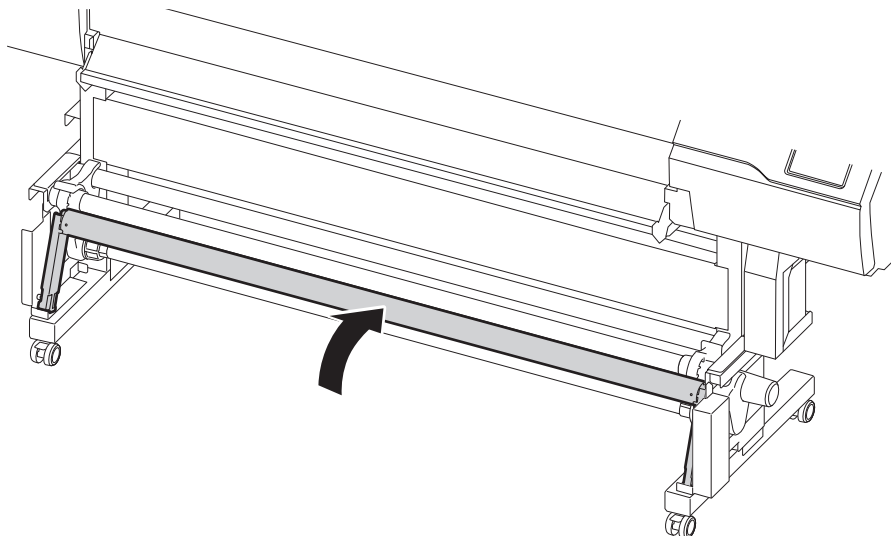

Precautions When Operating the Power Supply

IMPORTANT

Always keep the main power switched on.

Never switch off the main power. Leaving the main power enables automatic maintenance to be carried out periodically. If the automatic maintenance is not carried out, it may result in the breakdown of this machine, such as the breakdown of the print heads.

Never switch off the main power or unplug the power cord suddenly while operation is in progress.

Switching off the main power or unplugging the power cord suddenly while operation is in progress may damage the print heads. Be sure to first switch off the sub power. If the main power is accidentally switched off, immediately turn the main power and sub power back on.

Sleep Mode (Power-saving Feature)

This machine is provided with a power-saving feature that switches to a low-power "sleep mode" when a fixed interval passes with no operation. The factory default for the time after which the machine switches to sleep mode is 30 minutes. Using the operation panel or performing operations such as sending print data from the computer restores the machine to its normal mode.

This sleep mode setting can be changed. However, we recommend setting the activation time for sleep mode to 30 minutes or less to reduce power consumption and prevent problems such as overheating.

RELATED LINKS

- [P. 277 Setting the Activation Interval for Sleep Mode \(Power-saving Feature\)](#)

Setup of New Media

CAUTION

Do not touch the dancer roller needlessly.

The media take-up unit and feeder may move suddenly, which may result in injury.

Setup of Roll Media

Load the roll media on the printer. When the loading is finished, [Output possible.] is displayed as the status. This work is referred to as "Setup of Media."

CAUTION

Load the roll media correctly.

Otherwise the media may fall and cause injury.

CAUTION

The roll media is approximately 45 kg (99 lb.) (54-inch model: 35 kg [77 lb.]).

To avoid injury, handle the roll media with care.

CAUTION

Never load media that weighs over 45 kg (99 lb.) (54-inch model: 35 kg [77 lb.]).

The machine may fail to withstand the weight and tip over or cause the media to fall.

1. Installing the Media on the Media Holders

⚠ WARNING

Handling roll media is an operation that must be performed by 2 persons or more, and care must be taken to prevent falls.

Attempting to lift heavy media in a manner that taxes your strength may cause physical injury. Also, if dropped, such items may cause injury.

MEMO

The media holders of this machine are designed to be used with a paper tube (core) with an inner diameter of 2 inches or 3 inches.

Perform a printing test for adjustment in [5. Configure settings to match the media. \(P. 57\)](#). Load media which can secure the printing area for the printing test. The printing test width is the following.

- [Simple Correction (Auto)]: Approx. 290 mm (11.42 in.)
- [Detailed Correction (Manual)]: Approx. 375 mm (14.76 in.)

Procedure

1. Tap the operation panel.

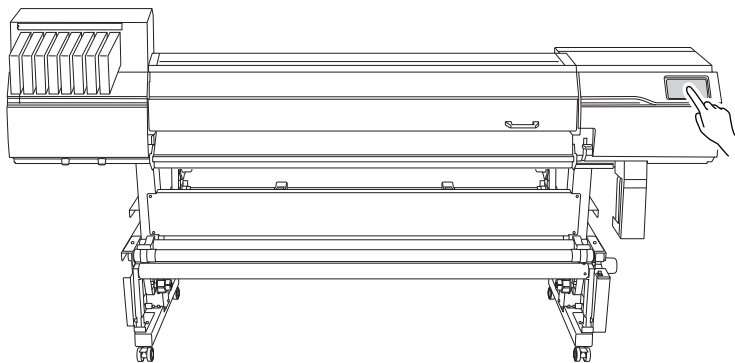

2. When instructions appear on the screen, tap the operation panel again.

The machine sub power is switched on.

3. When using a take-up unit, use the following procedure to set it.

Make sure the following settings match the loading method and output method of the actual media.

The settings will have to be changed from the defaults when:

- When using weak media.
- Taking-up the media with inward curl.
- Taking up the media during cutting process in the Print & Cut mode

- (1) Tap .
- (2) Tap [Preferences]>[Take-up].
- (3) Tap [Take-up during Cutting].
- (4) Select [Enabled] or [Disabled].

[Enabled]	The media is taken up during cutting while slack is being created. This prevents the media from sticking to the floor. Make sure the media is taken up at least halfway around the paper tube beforehand.
[Disabled]	The media is taken up after all cutting finishes.

MEMO

- Default setting: [Disabled]
- [Enabled] cannot be performed in the following situations:
 - [Blade Adjustment]>[Printing Test]
 - [Print & Cut Position Adjustment]>[Printing Test 1(Misalignment Check)]/[Printing Test 2(Correction Values)]
 - [Crop Cut Position Adjustment]>[Printing Test 1(Misalignment Check)]/[Printing Test 2(Correction Values)]

IMPORTANT

When [Preferences]>[Take-up]>[Enabled] is set, to preserve cut quality, the speed may be limited to the optimum speed for [Cutting Speed] and [Rise Movement Speed] depending on the set media.

[P. 200 Fine-tuning the Cutting Conditions](#)

- (5) Tap [Save].
- (6) Tap [Take-up Method].
- (7) Select [Loose Winding] or [Tension Winding].

[Loose Winding]	The media is taken up with some slack. This is suited to PVC and other such stiff or slippery media.
[Tension Winding]	The media is stretched and taken up. This is suited to tarpaulin and other such weak media and media that does not slip easily. Even if [Tension Winding] is set, if [Enabled] is enabled, the media is taken up while slack is being created.

MEMO

- Default setting: [Loose Winding]

- (8) Tap [Save].
- (9) Tap [Take-up Direction].
- (10) Select [Backward] or [Forward].

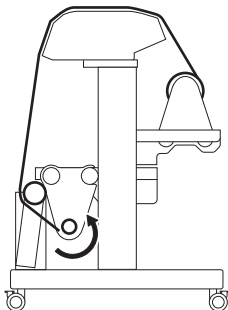
[Forward]	<p>The media is taken up onto the paper tube with the printed surface on the outside.</p> 
-----------	---

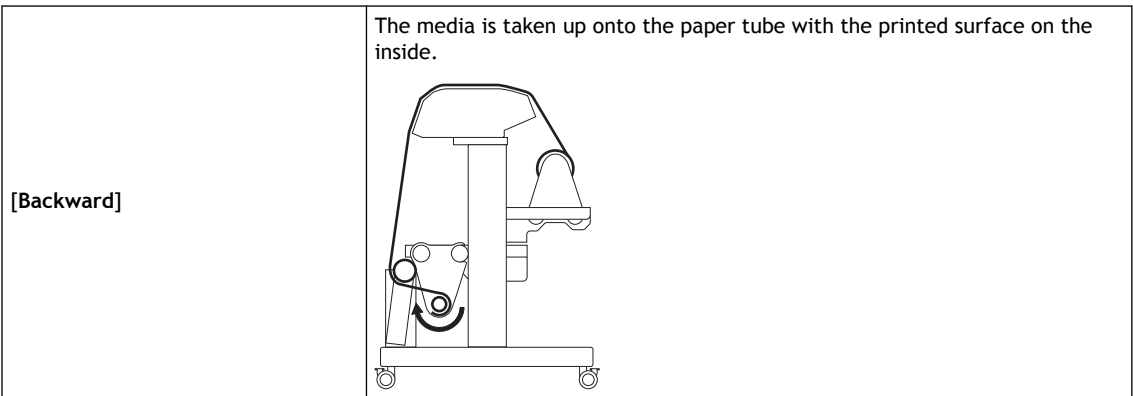

MEMO

- Default setting: [Forward]

(11) Tap [Save].

(12) Tap  to return to the home screen.

4. Check that the dancer roller has lowered toward the rear.

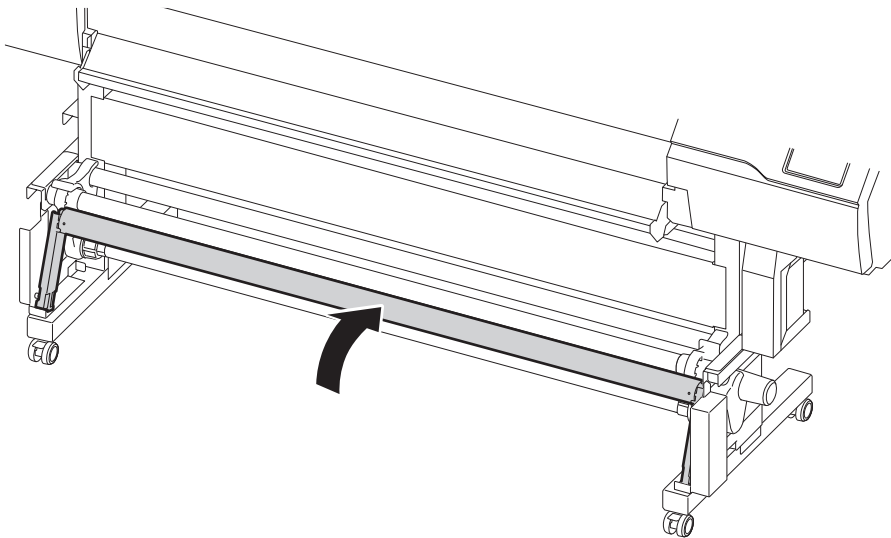

5. Open the front cover.

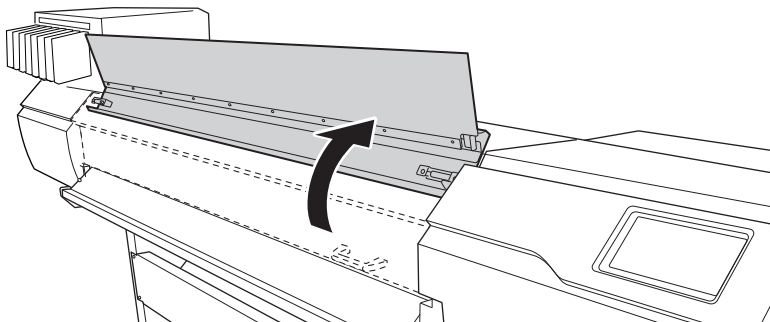

6. Move the media clamps to the outside of the grit rollers on the left and right edges respectively.

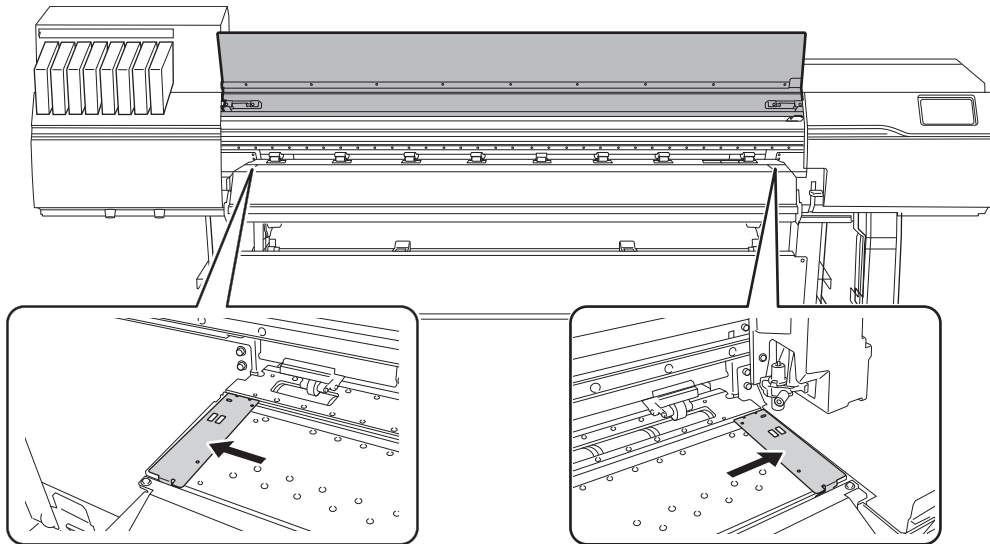

7. Release the locking mechanisms of the media holders, and then draw them to the left and right ends respectively.

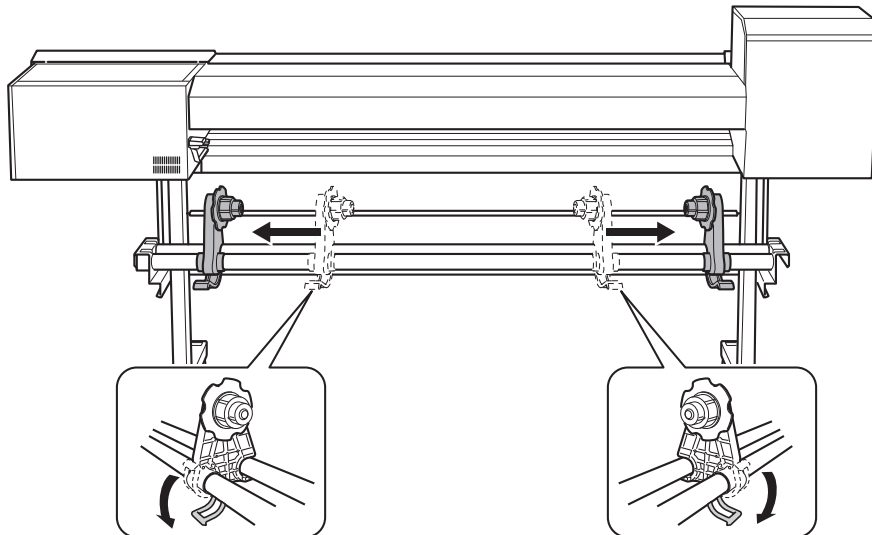

8. Place the media on the machine.

IMPORTANT

Do not leave media on the media stays or the shafts for a long period of time. The media may become deformed. Exercise caution.

- Roll media with an outer diameter of 220 mm (8.66 in.) or less

Place the media stays at positions that are 1/4 the length of the media from each end of the media, and then load the media.

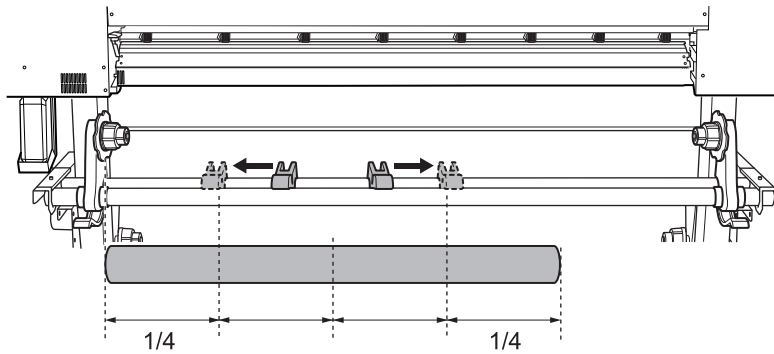

- Roll media with an outer diameter exceeding 220 mm (8.67 in.)
 - a. Rotate the media stays to draw them to the media holders.

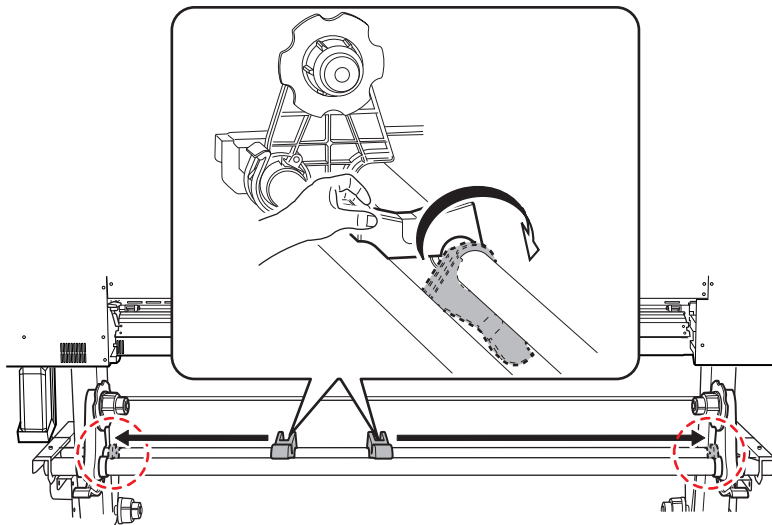

- b. Place the media directly between the two shafts.

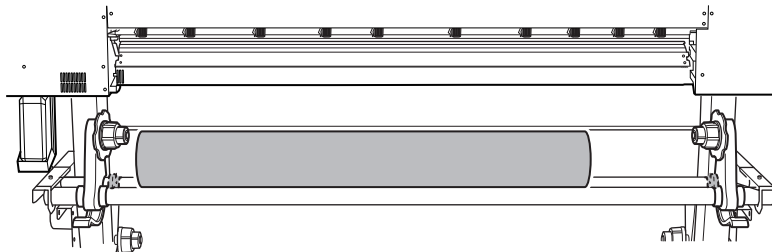

9. Fit the paper tube (core) of the media onto the end cap of the left media holder.

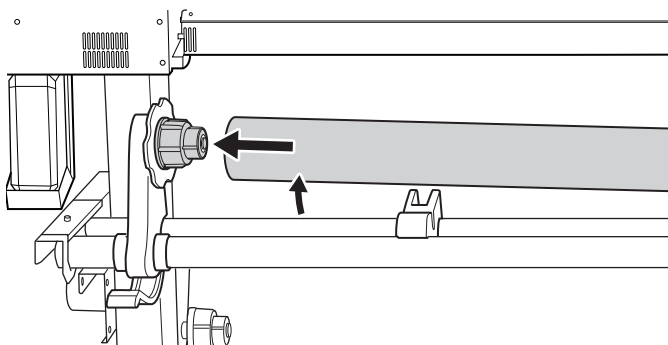

10. Move the right media holder to fit its end cap onto the paper tube (core) of the media.
Fit the paper tube onto the media holders securely to prevent the media from moving easily.

IMPORTANT

Do not secure the media holders in place just yet.

In the following procedure, you will adjust the positions of the media holders before securing them in place. Do not secure them in place just yet.

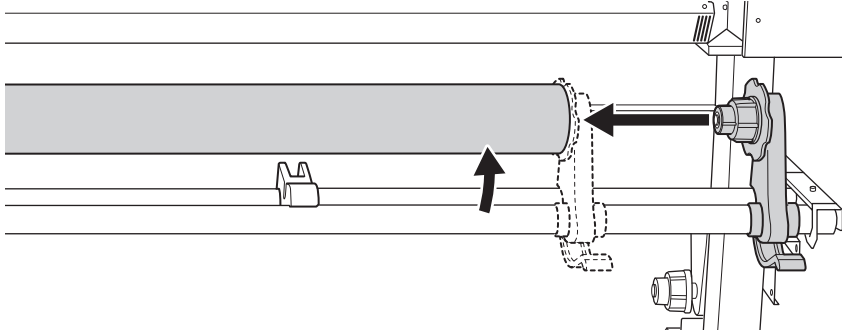

The next operation to perform varies depending on the media type and the Preferences. Proceed as shown below.

- For general media: [2. A: Determine the positions of the media.](#) (P. 40)
- For transparent media or if [Preferences]>[Media Edge Detection] is set to [Disable]: [2. B: Determining the Positions of Media \(If \[Media Edge Detection\]: \[Disable\]\)](#) (P. 45)

2. A: Determine the positions of the media.



This section describes how to use the suction fan to prevent media skewing.

Because the suction fan does not operate, the following procedure cannot be used to load media when using transparent media or media with high reflectance whose edges cannot be detected, or when [Disable] is set for [Preferences]>[Media Edge Detection]. In these cases, refer to [2. B: Determining the Positions of Media \(If \[Media Edge Detection\]: \[Disable\]\)\(P. 45\)](#).

By default, [Skewing Correction Support at Setup] is set to [Enable].

Procedure

1. Set the [Skewing Correction Support at Setup].

- (1) Tap .
- (2) Tap [Preferences]>[Skewing Correction Support at Setup].
- (3) Select [Enable] and tap [Save].
- (4) Press  to return to the home screen.

2. Determine the left and right positions of the media with the grit patterns used as the reference.

Note the following points when determining the positions.

- Hold the media holders from the outside and move them.
- Ensure that the left edge of the media is positioned so that it is within the range of the grit pattern of the left edge.
- Ensure that the right edge of the media is positioned so that it is within the range of one of the grit patterns.

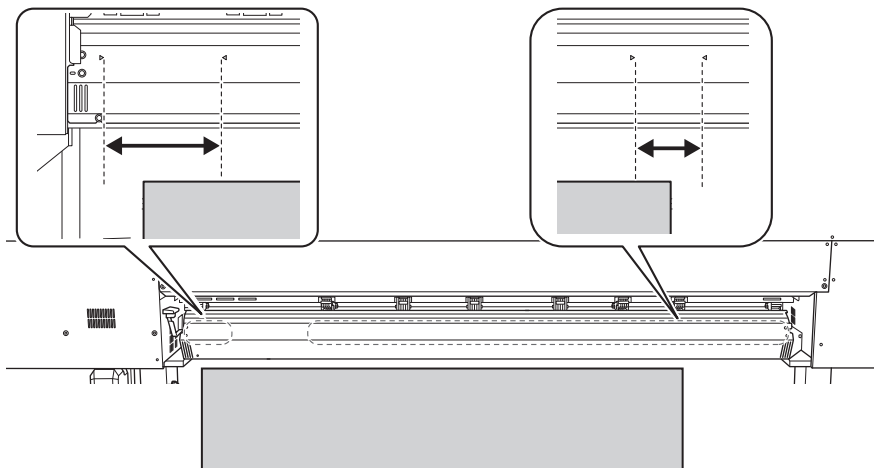

WARNING

Do not hold places other than those instructed. Do not move the media by holding it directly.

Doing so may cause the media to fall off the media holder and cause injury.

IMPORTANT

Firmly decide the left and right side positions of the media at this point.

After this procedure is completed, if the left and right side positions do not fit the proper positions when securing the media with pinch rollers, you will have to go back to this step to redo this procedure. If you just

hold the media to readjust its position forcibly, the media will be skewed during printing, which will have an adverse effect on the printing results.

3. Secure the media holders.

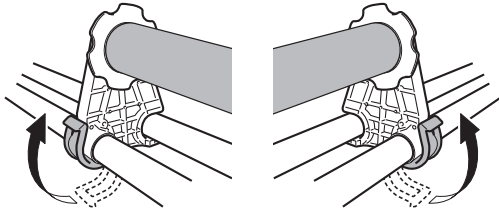

4. Use the following procedure to load the media.

Doing so will prevent media skewing.

- (1) Pass the leading edge of the media between the pinch rollers (①) and the grit rollers (②).

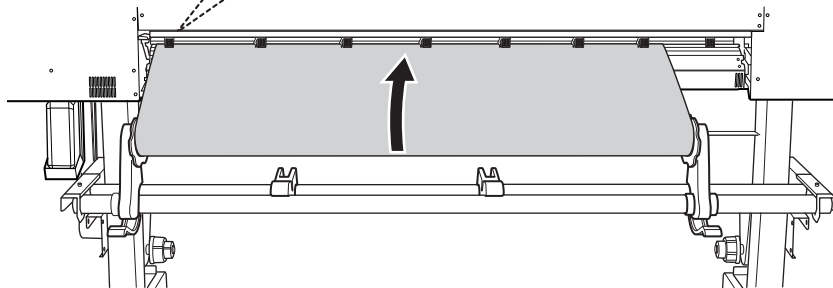
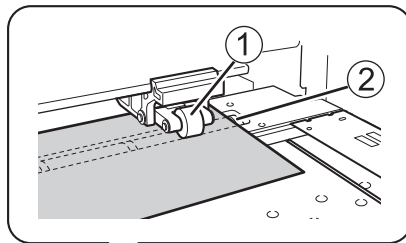

- (2) Feed the media until you hear a beep, and then additionally feed approximately 20 cm (7.87 in.) of the media.

You will hear a beep. Approximately 5 seconds later, you will hear two beeps, and then the suction fan will activate. While this fan is operating, the position of the media will be maintained even if you remove your hands from it.

- (3) Hold the media holder flange, turning it in the take-up direction to eliminate the slack in the media.

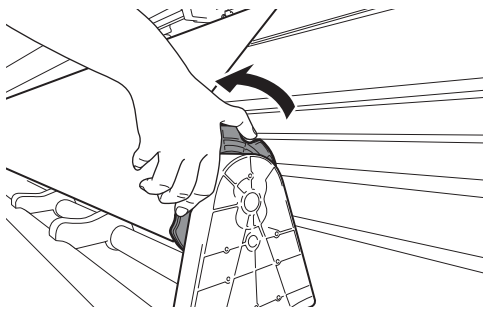

- (4) Once the media is taut, additionally take up approximately 10 cm (3.94 in.) of media.

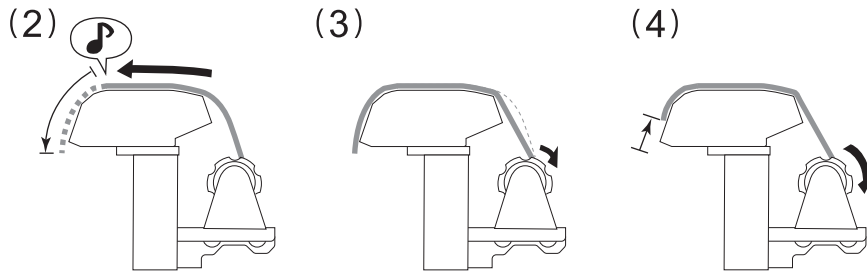

MEMO

If you take up too much media, you will hear two short beeps and the suction fan will stop. Take up the media, and then redo the procedure from Step (1).

5. (Move to the front of the printer.) Make sure both edges of the media are above the grit rollers. Be sure to place the right edge of the media on the right-end grit roller.

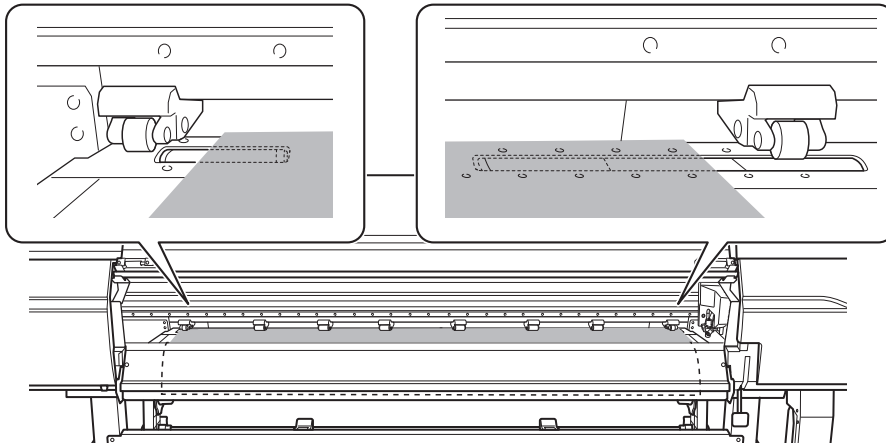

6. Move the left and right pinch rollers, placing them on both edges of the media. Position them approximately 10 mm (0.39 in.) from each edge of the media.

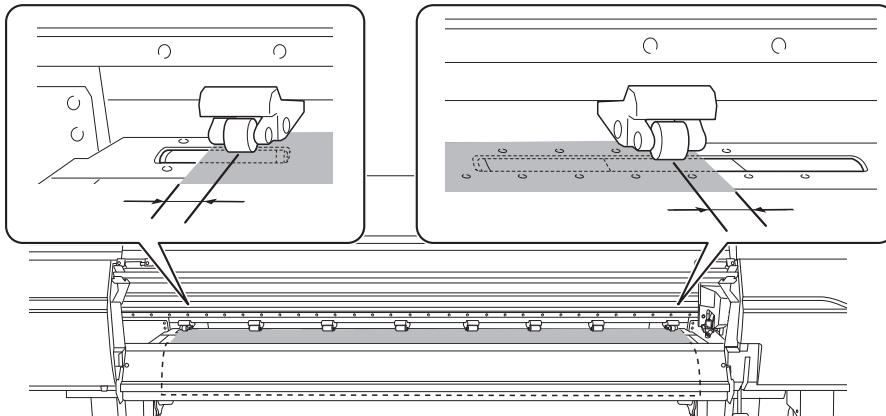

IMPORTANT

- Be sure to use the left and right pinch rollers. The force with which the media is pinched varies between the middle pinch rollers and the left and right pinch rollers. Using the middle pinch rollers to pinch the media edges will lead to unstable media feeding.
- If you want to readjust the media position, return to the back of the printer, release the media holders, and then redo the procedure from Step 2. If you just stand at the front of the printer and hold the media to

readjust its position forcibly, the media will be skewed during printing or will come loose, which will affect the printing quality.

MEMO

To smoothly move the pinch rollers, push down close to the rail.

7. Move the middle pinch rollers (B) over all the remaining grit rollers (A) covered by the media. There are grit patterns (C) wherever there are grit rollers.

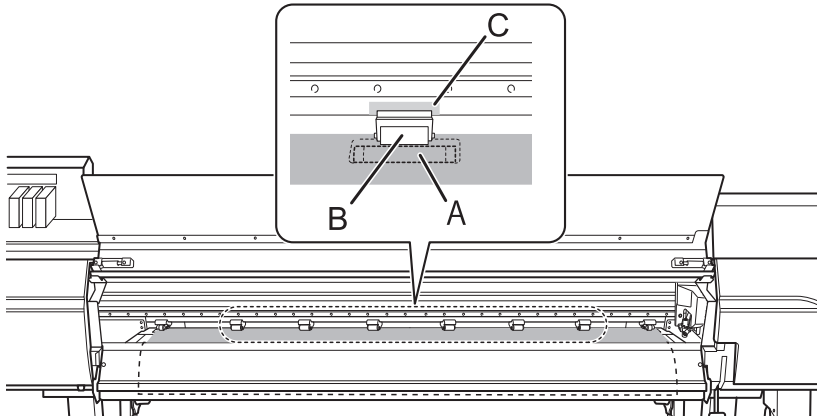

IMPORTANT

- Place the middle pinch rollers over all the grit patterns within the media width. If you have forgotten to place the middle pinch rollers, the media will be skewed during printing or will come loose, which will have an effect on the printing quality.
- The middle pinch roller will not lower onto the three grit rollers from the right end. Place the middle pinch roller on a grit roller other than these three.

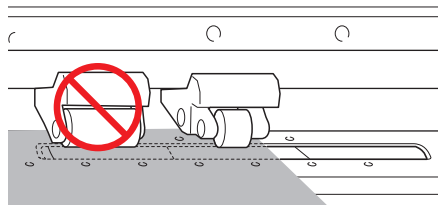

- There may be extra middle pinch rollers depending on the width of the media being used. Move the extra middle pinch rollers to positions where no grit patterns are present. Where no grit patterns are present, the middle pinch rollers will not come down.

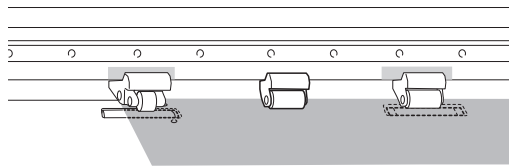

8. Lower the loading lever (front). The media is held in place.

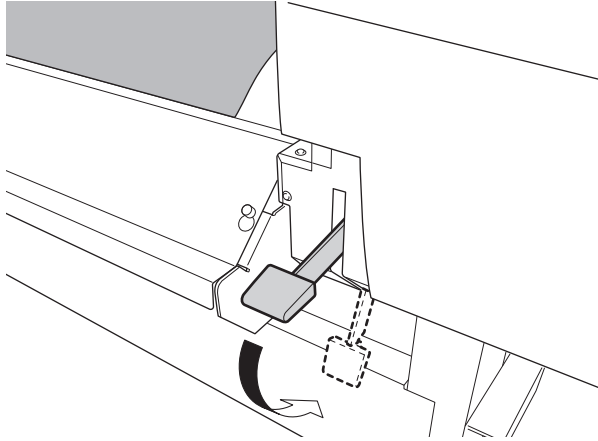

IMPORTANT

If you want to readjust the media position, return to the back of the printer, release the media holders, and then redo the procedure from Step 2. If you just stand at the front of the printer and hold the media to readjust its position forcibly, the media will be skewed during printing or will come loose, which will affect the printing quality.

9. Line up the edges of the media with the centers of the holes of the left and right media clamps.

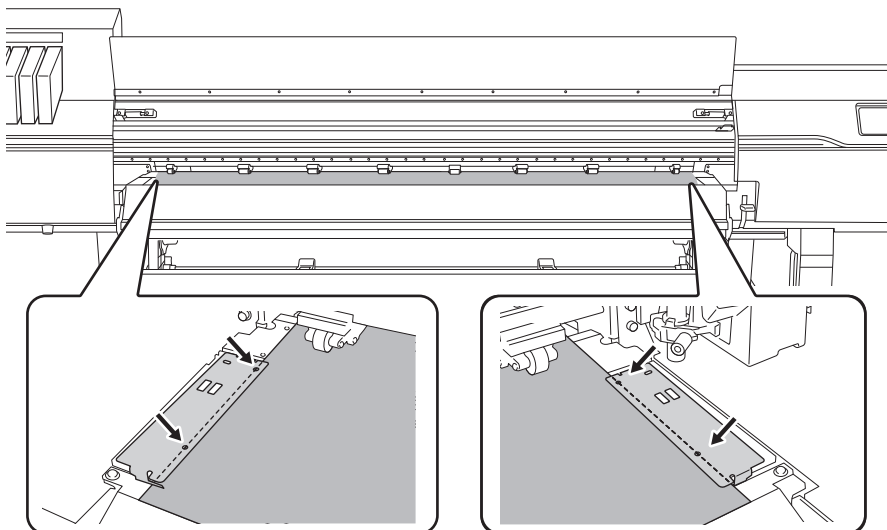

IMPORTANT

Be sure to use the media clamps when you set up media.
If you load the media clamps directly before printing after the media setup is complete, the machine may print on the media clamps.



10. Close the front cover.

2. B: Determining the Positions of Media (If [Media Edge Detection]: [Disable])

Use the following procedure to determine the positions of the media when using transparent media or media with high reflectance whose edges cannot be detected, and when [Preferences]>[Media Edge Detection] is set to [Disable].

Procedure

1. Set the [Skewing Correction Support at Setup].

- (1) Tap .
- (2) Tap [Preferences]>[Skewing Correction Support at Setup].
- (3) Select [Disable] and tap [Save].
- (4) Press  to return to the home screen.

2. Determine the left and right positions of the media with the grit patterns used as the reference.

Note the following points when determining the positions.

- Hold the media holders from the outside and move them.
- Ensure that the left edge of the media is positioned so that it is within the range of the grit pattern of the left edge.
- Ensure that the right edge of the media is positioned so that it is within the range of one of the grit patterns.

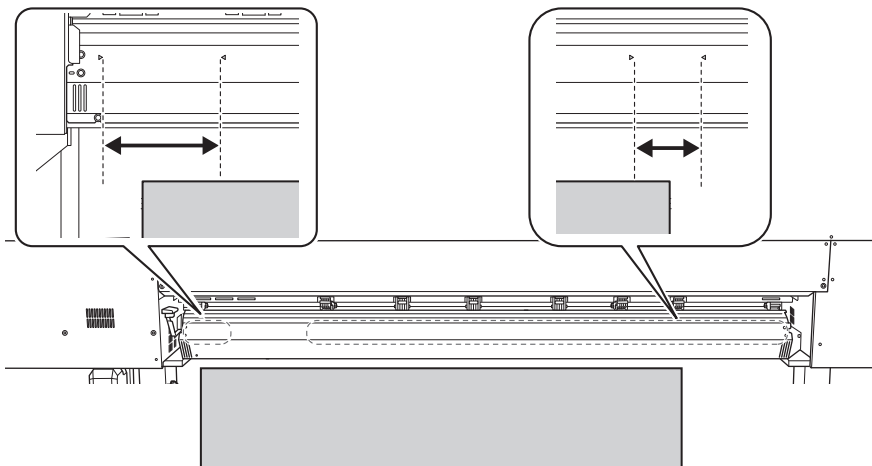

WARNING

Do not hold places other than those instructed. Do not move the media by holding it directly.

Doing so may cause the media to fall off the media holder and cause injury.

IMPORTANT

Firmly decide the left and right side positions of the media at this point.

After this procedure is completed, if the left and right side positions do not fit the proper positions when securing the media with pinch rollers, you will have to go back to this step to redo this procedure. If you just hold the media to readjust its position forcibly, the media will be skewed during printing, which will have an adverse effect on the printing results.

3. Secure the media holders.

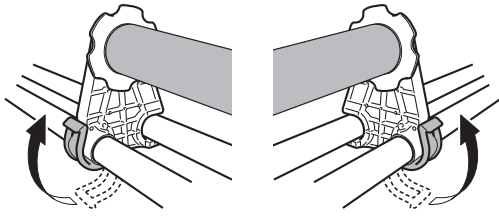

4. Pass the leading edge of the media between the pinch rollers (①) and the grit rollers (②).

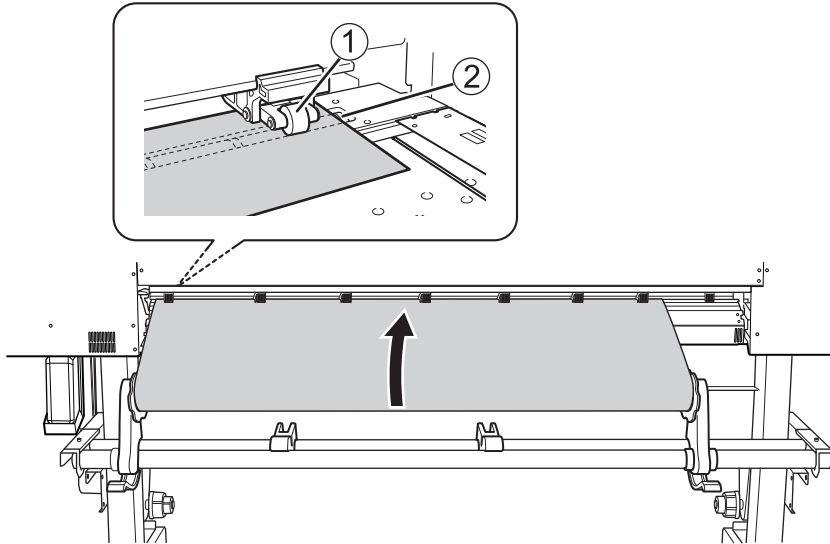

5. Lower the loading lever (rear).
The media is held in place.

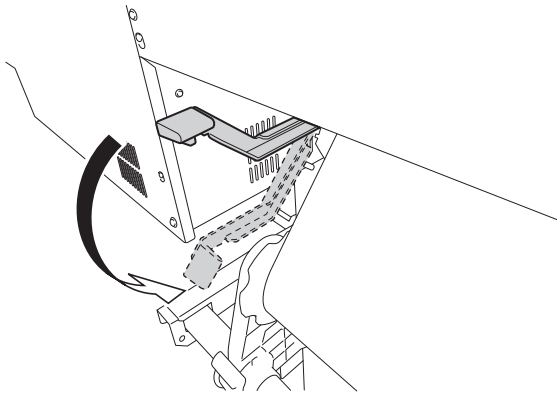

6. (Move to the front of the printer.) Gently hold down the media and raise the loading lever (front).

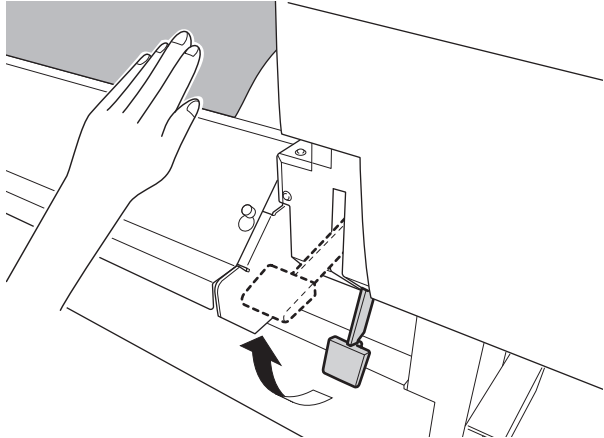

7. Pull out the media over the apron.

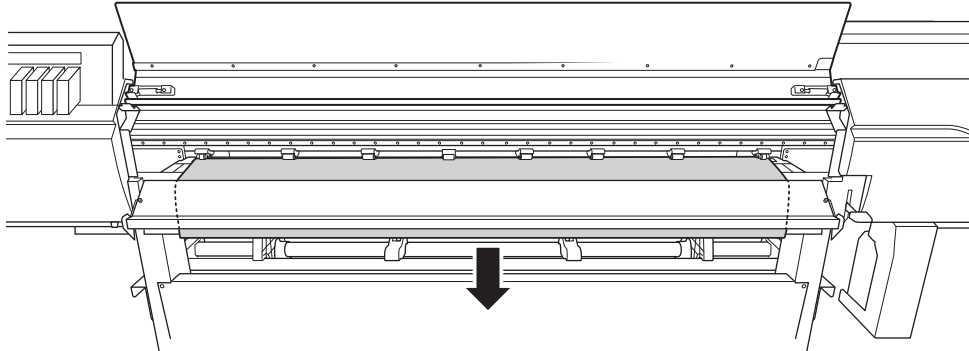

8. Make sure both edges of the media are above the grit rollers. Be sure to place the right edge of the media on the right-end grit roller.

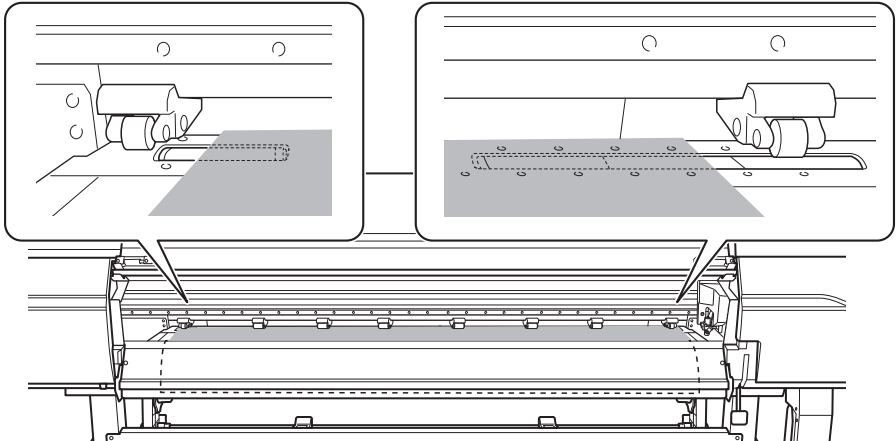

9. Move the left and right pinch rollers, placing them on both edges of the media. Position them approximately 10 mm (0.39 in.) from each edge of the media.

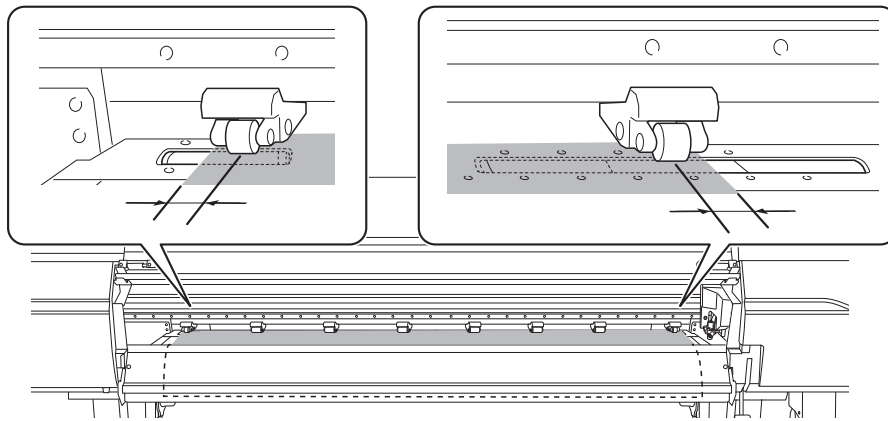

IMPORTANT

- Be sure to use the left and right pinch rollers. The force with which the media is pinched varies between the middle pinch rollers and the left and right pinch rollers. Using the middle pinch rollers to pinch the media edges will lead to unstable media feeding.
- If you want to readjust the media position, return to the back of the printer, release the media holders, and then redo the procedure from Step 2. If you just stand at the front of the printer and hold the media to readjust its position forcibly, the media will be skewed during printing or will come loose, which will affect the printing quality.

MEMO

To smoothly move the pinch rollers, push down close to the rail.

- 10. Move the middle pinch rollers (B) over all the remaining grit rollers (A) covered by the media. There are grit patterns (C) wherever there are grit rollers.**

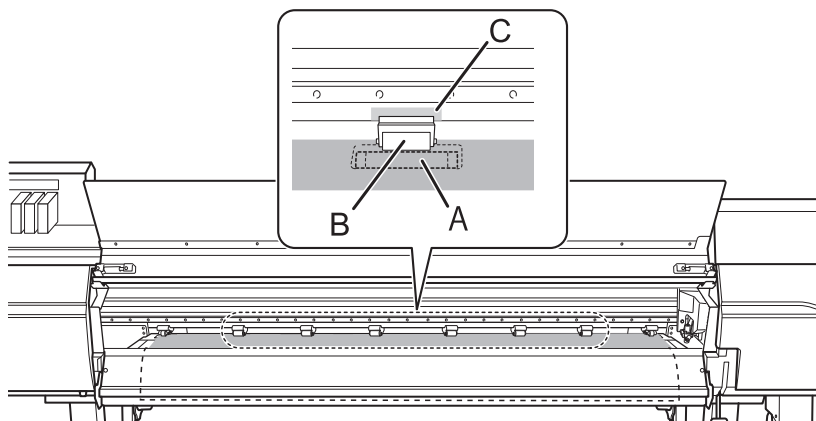

IMPORTANT

- Place the middle pinch rollers over all the grit patterns within the media width. If you have forgotten to place the middle pinch rollers, the media will be skewed during printing or will come loose, which will have an effect on the printing quality.
- The middle pinch roller will not lower onto the three grit rollers from the right end. Place the middle pinch roller on a grit roller other than these three.

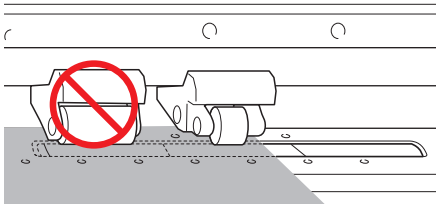

- There may be extra middle pinch rollers depending on the width of the media being used. Move the extra middle pinch rollers to positions where no grit patterns are present. Where no grit patterns are present, the middle pinch rollers will not come down.

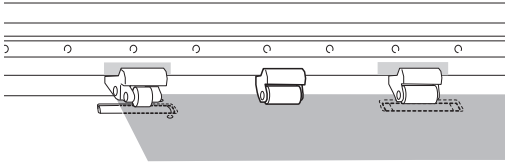

11. Hold the media at the center and pull it out, being sure to keep it straight and all areas of the media to be taut.

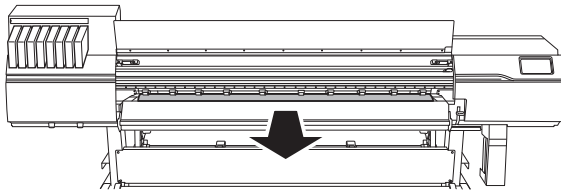

Good

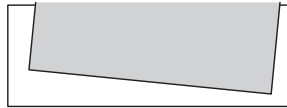

Not good

12. Lower the loading lever (front).
The media is held in place.

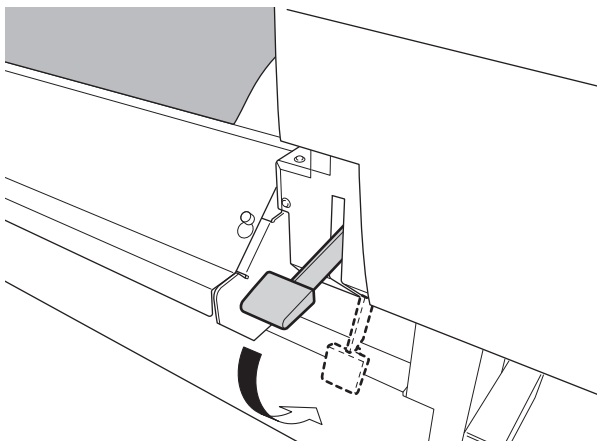

13. Line up the edges of the media with the centers of the holes of the left and right media clamps.

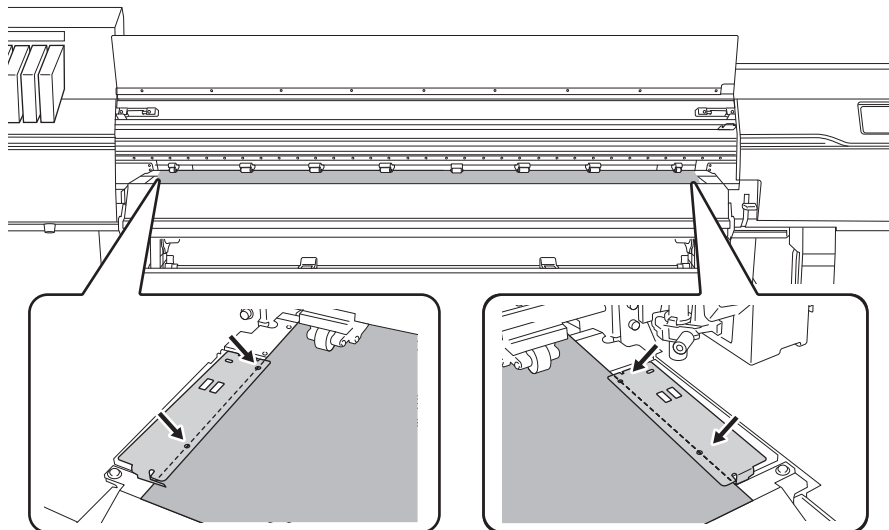

IMPORTANT

Be sure to use the media clamps when you set up media.

If you load the media clamps directly before printing after the media setup is complete, the machine may print on the media clamps.

14. Close the front cover.

3. Registering the Media

Procedure

1. Tap  [Setup].
2. Select [New].
3. Tap [Next].

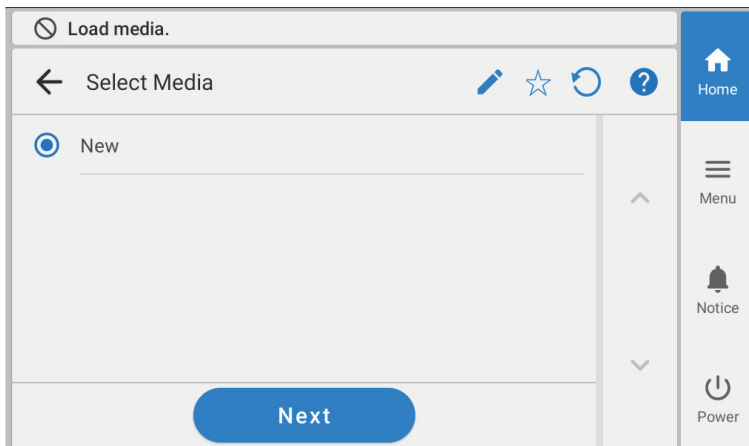

4. Enter a new media name and tap [OK].

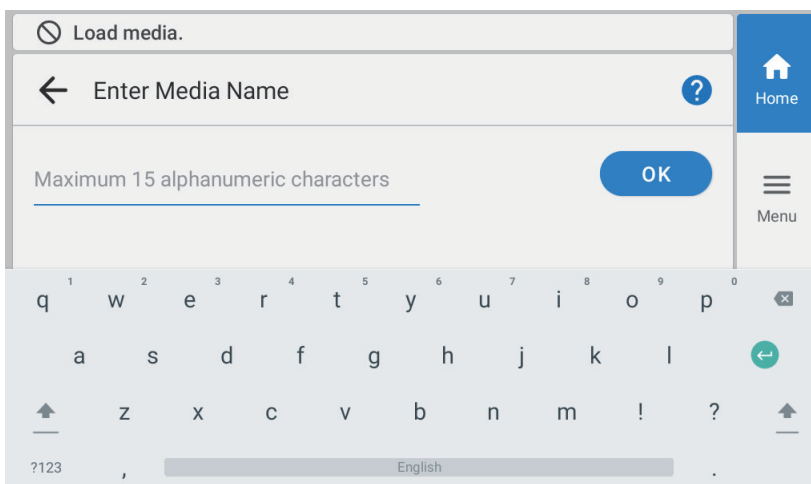

5. Check the name you have entered and tap [Next] if it is correct.
To make corrections, tap the name you entered.
6. The [Setup Method] screen appears. Select whether to use the take-up unit.
7. Tap [Start Setup].
The cutting carriage moves and detects the width of the media and the positions of the media clamps. This operation is called initialization.
8. When [The media could not be detected automatically. Manually set the printing] screen appears, use the following procedure to configure the settings.

MEMO

- This message may appear when media with high reflectance is set up.
- In the case of media where automatic media detection was not possible after new media was registered, the screen automatically changes to the [Printing Area Settings] screen in Step (2).

(1) Tap [OK].

(2) Tap [Change] on the [Printing Area Settings] screen.

The [Set the right edge of the printing area within the area specified by the pinch rollers.] screen appears.

(3) Hold down **<** or **>** to move the center of the blade (A) approximately 2 mm (0.08 in.) to the inside (B) from the left edge of the right pinch roller.

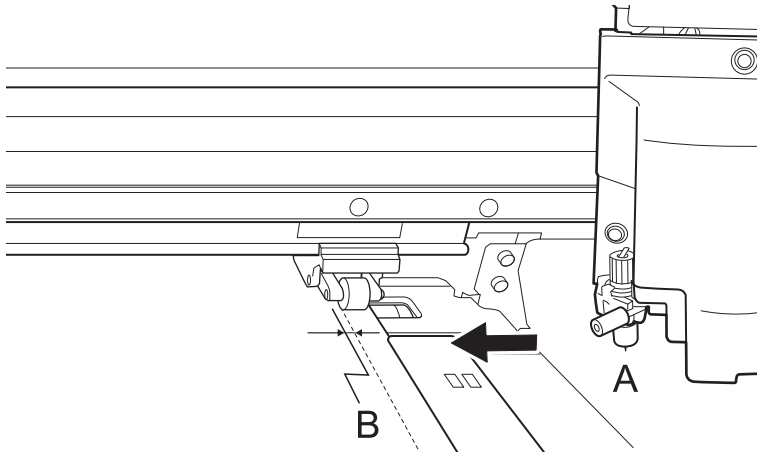

(4) Tap [OK].

The [Set the left edge of the printing area within the area specified by the pinch rollers.] screen appears.

(5) Hold down **<** or **>** to move the center of the blade (A) approximately 2 mm (0.08 in.) to the inside (B) from the right edge of the left pinch roller.

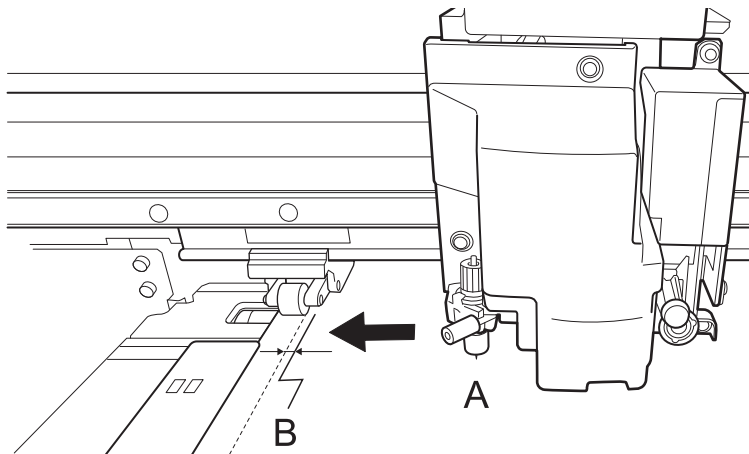

(6) Tap [OK].

The set left and right positions are applied to the [Printing Area (Width)].

(7) Tap [OK].

4. Loading the Media in the Take-up Unit

If you will not use the take-up unit, proceed to [5. Configure settings to match the media.](#) (P. 57).

Procedure

1. Follow the procedure below to load a paper tube on the media holders of the take-up unit.
Prepare a paper tube wider than the media that has been set up.

IMPORTANT

Paper tubes are consumable items.

Watch the condition of the paper tube and replace at an appropriate time so that the media can be taken up in good working order.

- (1) Release the media holders to enable their movement.

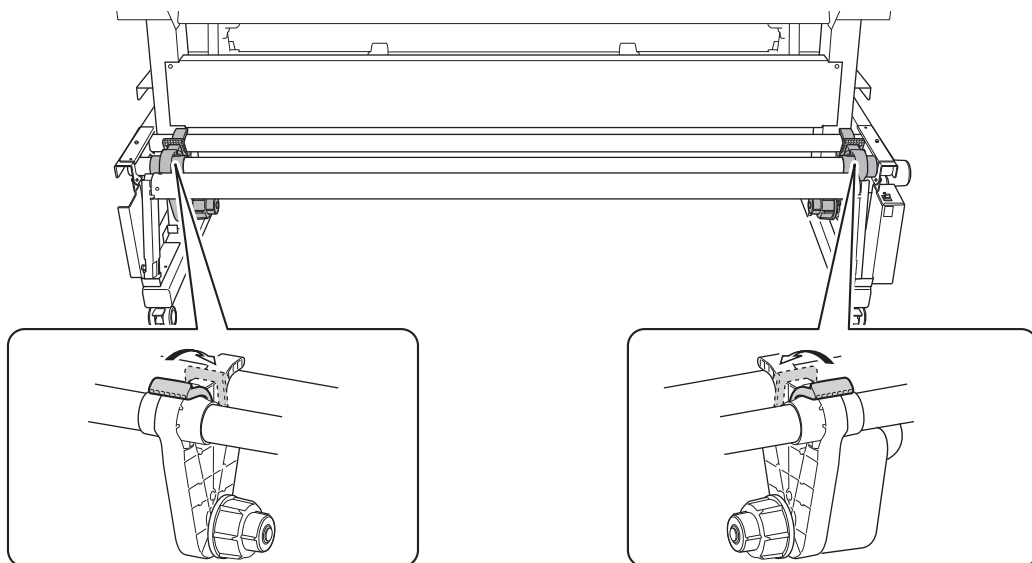

- (2) Draw the media holders to both left and right ends respectively.

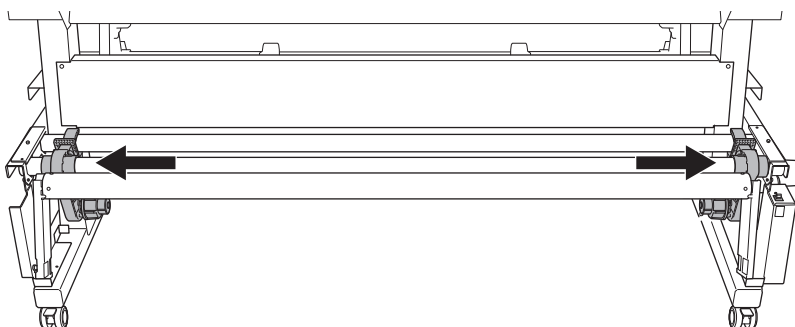

- (3) Fit the paper tube onto the right end cap.
Fit the paper tube securely right to the end of the end cap.
- (4) Push the left media holder into the paper tube.

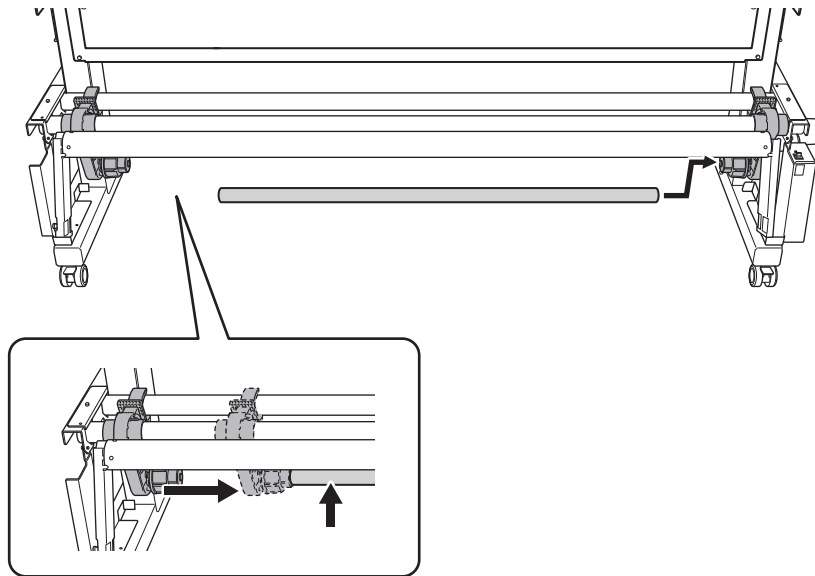

2. Tap  on the operation panel to feed out the media until the tip of the media reaches the paper tube. Media is fed out 10 mm (0.39 in.) each time you press this button. Holding down the key lets you feed out paper continuously.

MEMO

Feed out the media until it can wrap around at least 1/4 of the paper tube (or at least halfway around when rewinding during cutting).

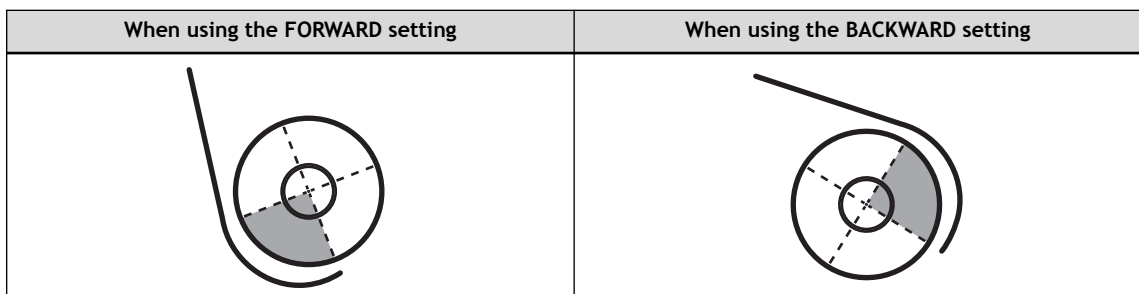

3. Follow the procedure below to adjust the positions of the media holders.
 - (1) Move both media holders so that it is possible to see the paper tube from both edges of the media. Hold the media holders from the outside and move them.

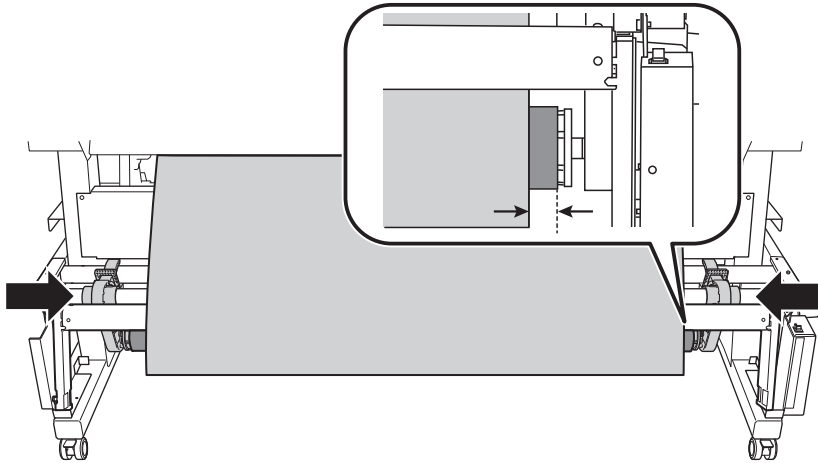

(2) Secure the left and right media holders.

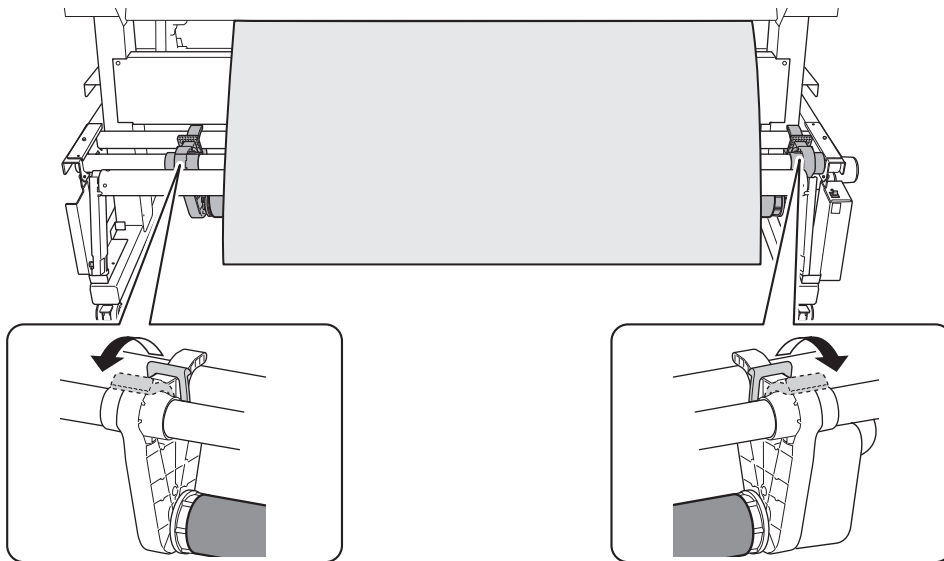

4. Follow the procedure below to secure the media on the paper tube.

Secure the media in the take-up direction set in step 3 of 1. [Installing the Media on the Media Holders\(P. 34\)](#).

- (1) While pulling the media so that it does not sag, secure the center of the media on the paper tube with adhesive tape.
 - (2) While pulling the media from the center toward the outer edges, secure the left and right edges of the media on the paper tube with adhesive tape.
- When using the FORWARD setting

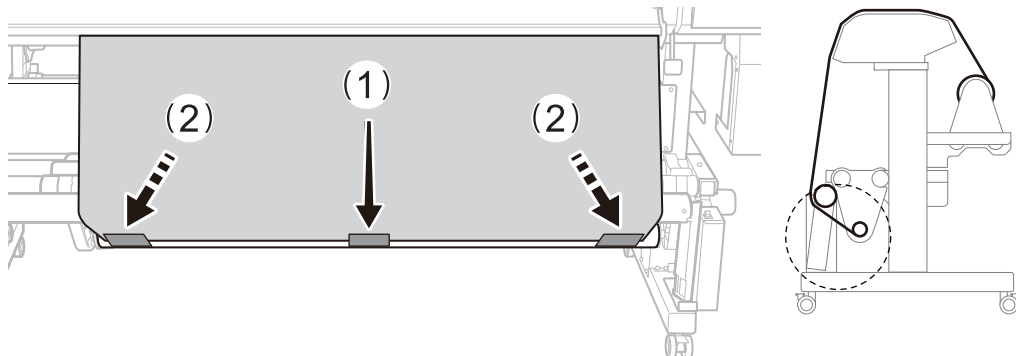

- When using the BACKWARD setting

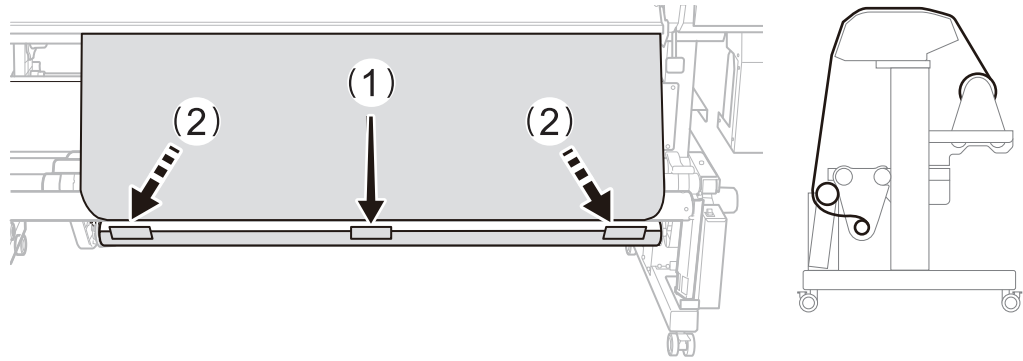

5. Tap [OK].
A small amount of the media is fed out.
6. Lower the dancer roller toward the front.

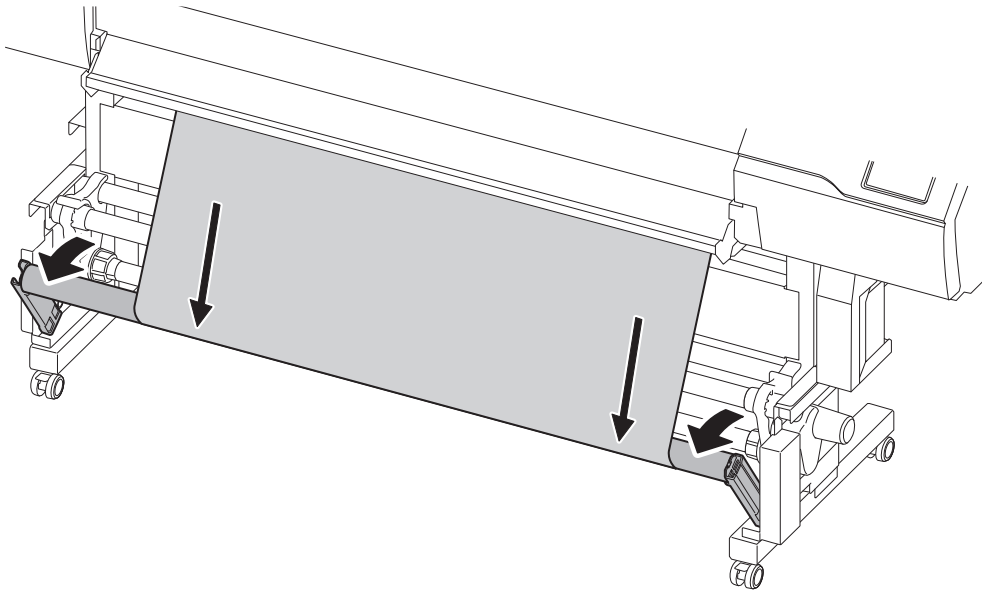

7. Tap [OK].

IMPORTANT

Remove when not using roll media.



Do not leave roll media loaded on the machine for a long period of time. Be sure to remove and store the media when not in use. Leaving the roll media loaded on the machine for a long period of time will cause the media to sag, which may deteriorate the printing quality and may also lead to motor errors.

5. Configure settings to match the media.

To ensure the optimal output according to the media size and type, set the minimal amount of items. All items set here can be set individually as well.









Procedure

1. On the [Select Media Output Type] screen, select the output type and tap [Next].
 - [Print Only/Print & Cut]
Proceed to step 2.
 - [Cut Only]
Switch to the [Multi Sensor Adjustment] screen. Tap [Execute] to perform automatic adjustment, then tap [OK]. This completes the settings for [Cut Only].

2. On the [Heater Temperature] screen, adjust the [Print Heater] and [Dryer] temperatures.
 - If this is not necessary, tap [Next].
 - Follow the procedure below to make changes.
 - a. Tap  or  to set the [Print Heater] or [Dryer] temperature.
 - b. Tap [Next].

3. Use the [Print Head Height] screen to adjust the print head height.
 - If this is not necessary, tap [Next].
 - Follow the procedure below to make adjustments.
 - a. Tap [Change]
 - b. Open the front cover.
 - c. Move the height-adjustment lever to adjust the head height.
 - d. Close the front cover.
 - e. Tap [OK].
 - f. Tap [Next].

For details on this work, refer to [Changing the Print Head Height\(P. 180\)](#).

4. Set the [Printing Test] and [Output Start Location] on the [Nozzle Drop-out Test] screen.
 - Proceed to step 5 if this step is not necessary.
 - Follow the procedure below to set [Output Start Location].
 - a. Tap [Output Start Location]>[Change].
 - b. Tap .
 - The cutting carriage moves to the current base point.
 - c. Tap     and move the cutter center to the position where you want to start cutting.
 - Tap  or  to move the media in the feed direction (forward-back). Tap  or  to move the cutting carriage in the scan direction (left-right).

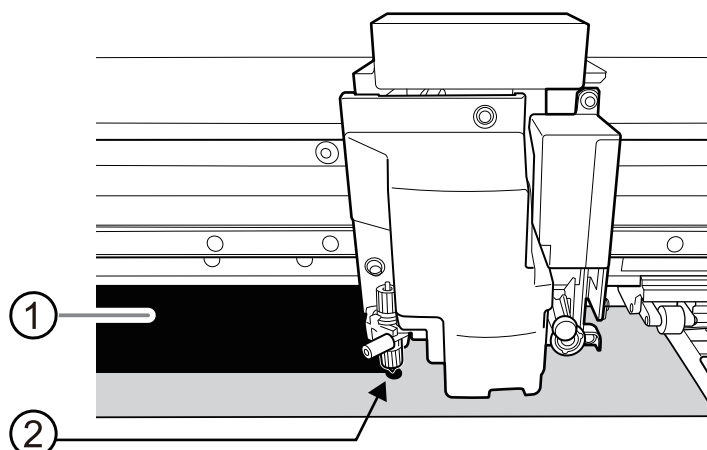

- ①: Printing area
- ②: Base point (right edge of the printing area)

d. Once the position has been decided, tap **[Set Base Point Here]** to confirm it.

The base point position is updated.

- Follow the procedure below to perform **[Printing Test]**.

Tap **[Printing Test]>[Execute]**. For details on what to do after the printing test, refer to [Normal Cleaning Method\(P. 318\)](#).

5. Tap **[Next]**.

6. On the **[Select Media Adjustment Method]** screen, select the adjustment method.

Here, the media feed correction for reducing horizontal bands and the correction of the landing position of the ink will be adjusted.

MEMO

- **[Simple Correction (Auto)]** is the recommended adjustment. You can determine the correction values with **[Detailed Correction (Manual)]**.

- Follow the procedure below to make automatic adjustments.

- a. Tap **[Simple Correction (Auto)]>[Next]**.
- b. Tap **[Execute]** on the **[Batch Automatic Correction]** screen.

Check the printing area required for the printing test before executing the test.

On successful completion of automatic adjustment, the home screen appears. This completes the settings.

For more information, refer to [Automatically Making Required Adjustments\(P. 175\)](#).

- Follow the procedure below to make manual adjustments.

- a. Tap **[Detailed Correction (Manual)]>[Next]**.
- b. Tap **[Execute]** on the **[Multi Sensor Adjustment]** screen.

Adjust the reading sensor to the optimal condition. If the adjustment failed, respond to the failure according to the information in [Correcting the Reading Sensor\(P. 220\)](#).

- c. Tap **[Next]**.

- d. Tap **[Printing Test]>[Execute]** on the **[Detailed Feed Correction (Manual)]** screen. Check the printing area required for the printing test before executing the test.

Set the correction values from the printing test result. For more information, refer to [Manual Adjustment: Reducing Horizontal Bands \(Feed Correction\)\(P. 176\)](#).

- e. Tap [Save and Proceed].
- f. Tap [Printing Test]>[Execute] on the [Detailed Media Gap Adjustment (Manual)] screen.
Set the correction values from the printing test result. For more information, refer to [Manual Adjustment: Adjusting the Misalignment of the Ink Landing Position \(Media Gap Adjustment\)\(P. 178\)](#).
- g. Tap [Save and Exit].

IMPORTANT

- When [Take-up] is set to [Disabled], rewind the media from the take-up unit when printing and cutting or just cutting to slacken the media. If sufficient media is not wound on the paper tube immediately after setup, this operation may not be performed well, lowering the cutting quality and preventing continued take-up. When performing cutting immediately after attaching the media to the paper tube, first feed enough media to carry out take-up a few times and set the base point.
- When [Take-up] is set to [Enabled], if sufficient media is not wound on the paper tube, this operation may not be performed well, lowering the cutting quality and preventing continued take-up. Take up the media at least halfway around the paper tube before setting the base point.

This completes the setup.

Setup of Sheet Media

Load the sheet media on the printer. When the loading is finished, [Output possible.] is displayed as the status. This work is referred to as "Setup of Media."

1. A: Determining the Positions of the Media

This section describes how to use the suction fan to prevent media skewing.

Because the suction fan does not operate, the following procedure cannot be used to load media when using transparent media or media with high reflectance whose edges cannot be detected, or when [Disable] is set for [Preferences]>[Media Edge Detection]. In these cases, refer to [1. B: Determining the Positions of Media \(If \[Media Edge Detection\]: \[Disable\]\)\(P. 66\)](#).

By default, [Skewing Correction Support at Setup] is set to [Enable].

MEMO

Perform a printing test for adjustment in [3. Configuring Settings to Match the Media\(P. 74\)](#). Load media which can secure the printing area for the printing test. The printing test width is the following.

- [Simple Correction (Auto)]: Approx. 290 mm (11.42 in.)
- [Detailed Correction (Manual)]: Approx. 375 mm (14.76 in.)

Procedure

1. Tap the operation panel.

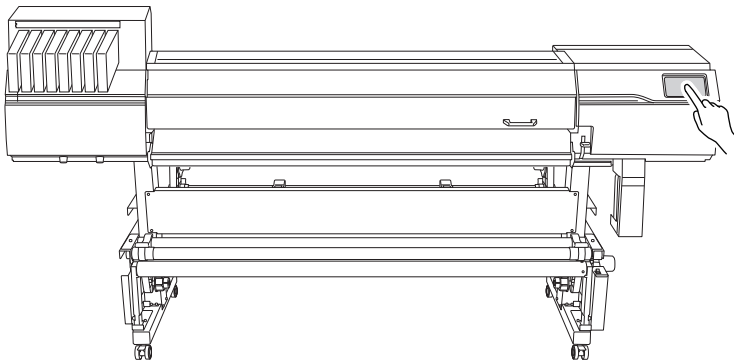

2. When instructions appear on the screen, tap the operation panel again.
The machine sub power is switched on.
3. Set the [Skewing Correction Support at Setup].
 - (1) Tap
 - (2) Tap [Preferences]>[Skewing Correction Support at Setup].
 - (3) Select [Enable] and tap [Save].
 - (4) Press to return to the home screen.
4. Open the front cover.
5. Move the media clamps to the outside of the grit rollers on the left and right edges respectively.

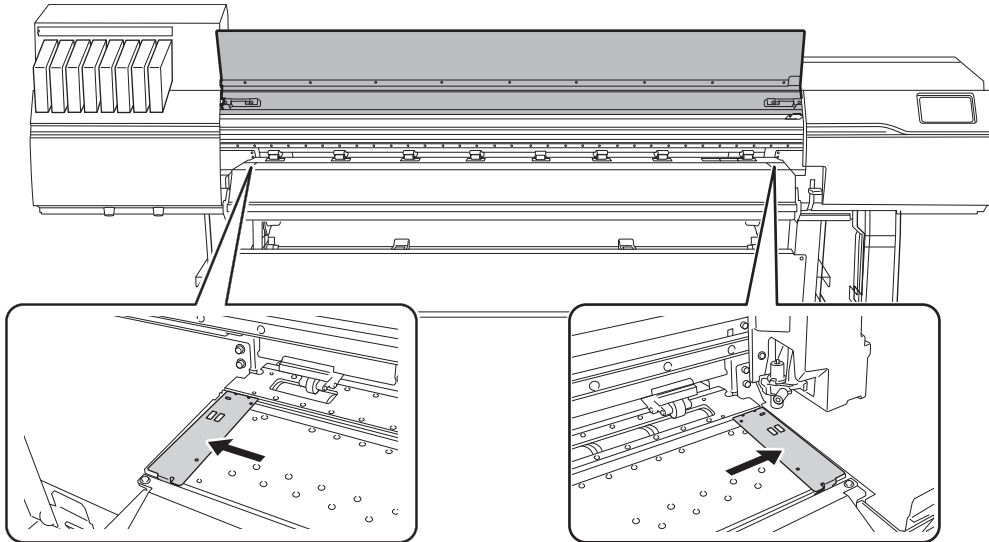

6. Move to the rear of the printer. Release the locking mechanisms of the media holders, and then draw them to the left and right ends respectively.

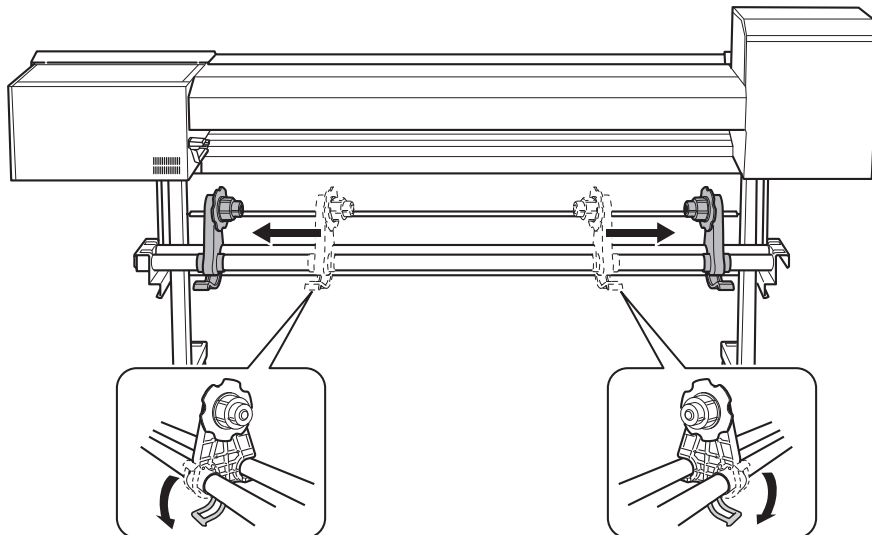

7. Determine the left and right positions of the media with the grit patterns used as the reference.

Note the following points when determining the positions.

- Ensure that the left edge of the media is positioned so that it is within the range of the grit pattern of the left edge.
- Ensure that the right edge of the media is positioned so that it is within the range of one of the grit patterns.

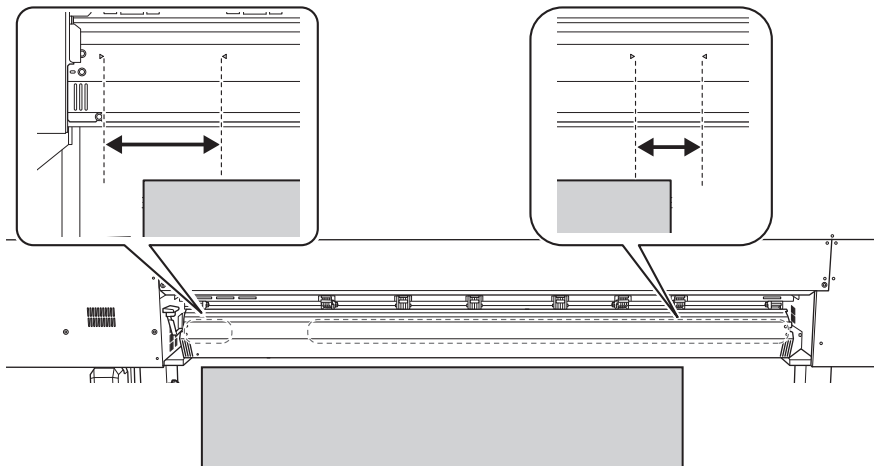

8. From the rear of the printer, pass the leading edge of the media between the pinch rollers (①) and the grit rollers (②).

You will hear a beep. Approximately 5 seconds later, you will hear two beeps, and then the suction fan will activate. While this fan is operating, the media will not move backward even if you remove your hands from it.

When loading the media from the front of the printer, feed the leading edge of the media (the side where printing will start) over the platen, and then pull the media to the front to activate the suction fan.

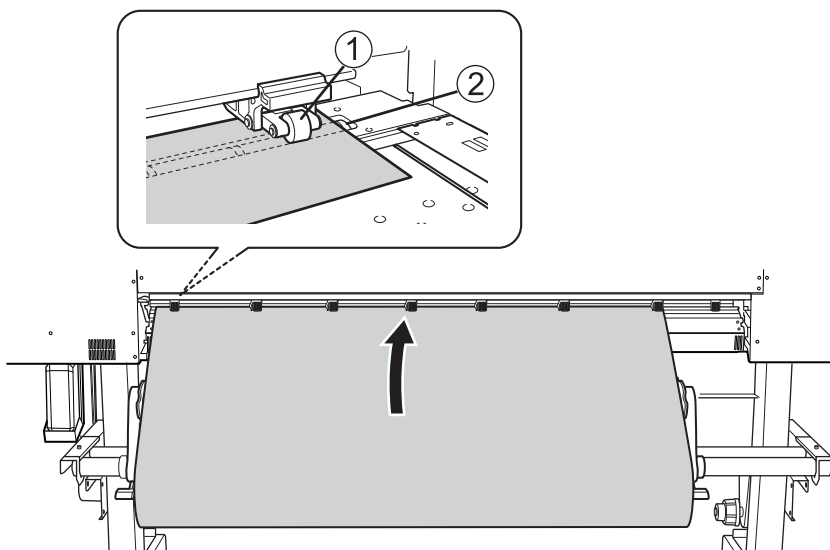

9. (Move to the front of the printer.) Make sure both edges of the media are above the grit rollers. Be sure to place the right edge of the media on the right-end grit roller.

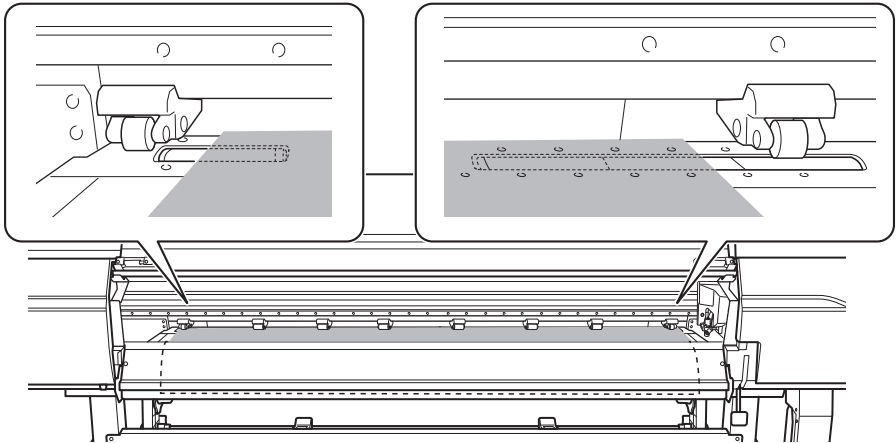

- 10. Move the left and right pinch rollers, placing them on both edges of the media. Position them approximately 10 mm (0.39 in.) from each edge of the media.

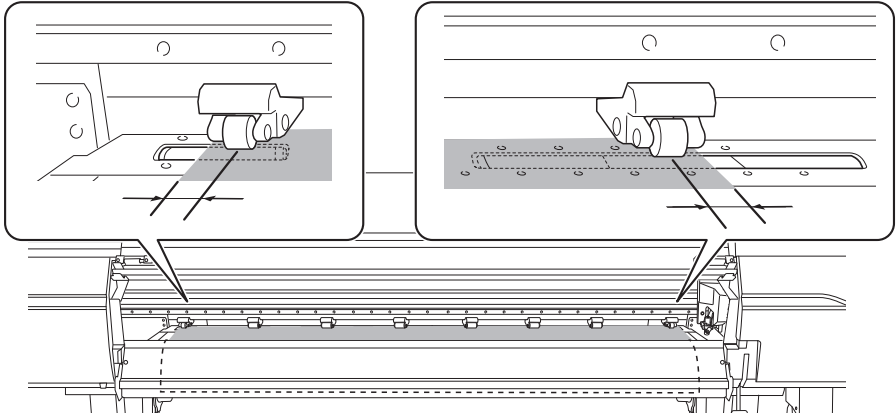

IMPORTANT

- Be sure to use the left and right pinch rollers. The force with which the media is pinched varies between the middle pinch rollers and the left and right pinch rollers. Using the middle pinch rollers to pinch the media edges will lead to unstable media feeding.
- If you want to readjust the media position before securing it in place, redo the procedure from step 7.

MEMO

To smoothly move the pinch rollers, push down close to the rail.

- 11. Move the middle pinch rollers (B) over all the remaining grit rollers (A) covered by the media. There are grit patterns (C) wherever there are grit rollers.

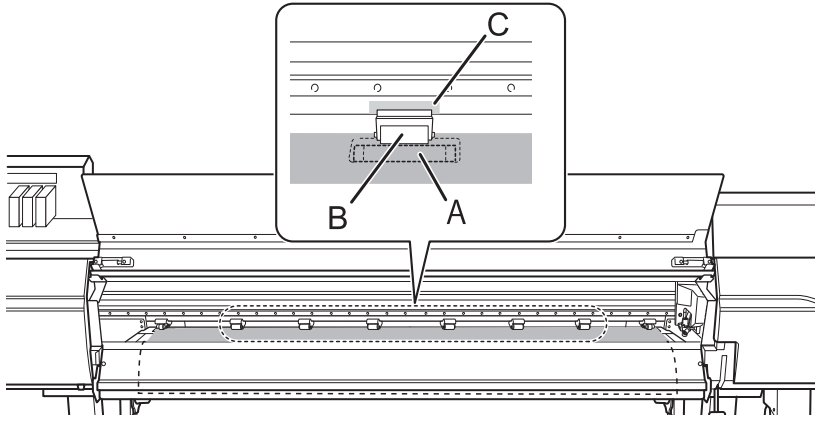

IMPORTANT

- Place the middle pinch rollers over all the grit patterns within the media width. If you have forgotten to place the middle pinch rollers, the media will be skewed during printing or will come loose, which will have an effect on the printing quality.
- The middle pinch roller will not lower onto the three grit rollers from the right end. Place the middle pinch roller on a grit roller other than these three.

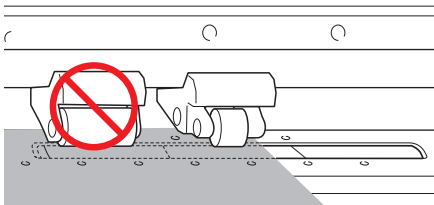

- There may be extra middle pinch rollers depending on the width of the media being used. Move the extra middle pinch rollers to positions where no grit patterns are present. Where no grit patterns are present, the middle pinch rollers will not come down.

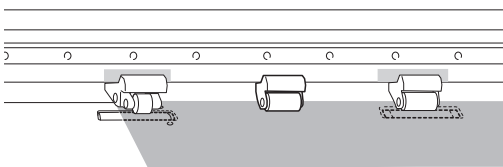

12. Lower the loading lever (front).

The media is held in place.

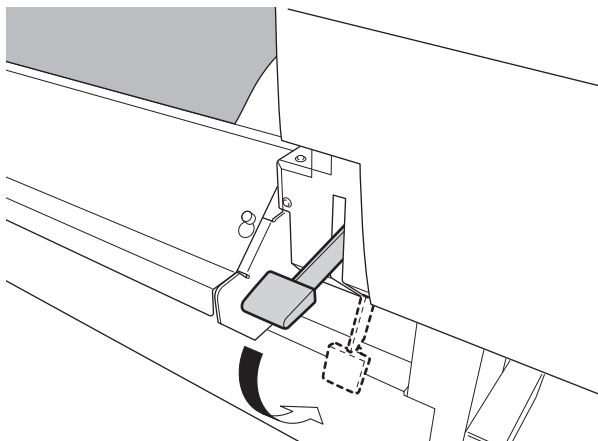

IMPORTANT

If you want to readjust the media position before securing it in place, redo the procedure from step 7.

13. Line up the edges of the media with the centers of the holes of the left and right media clamps.

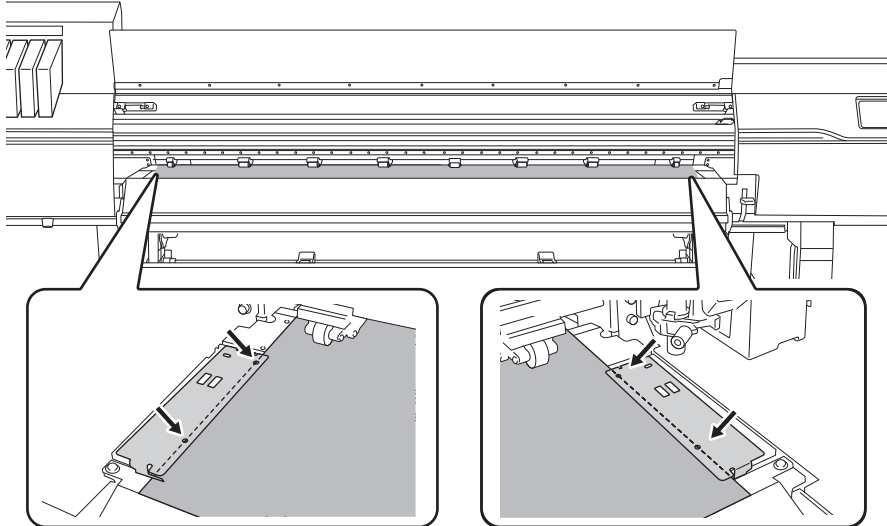
**IMPORTANT**

Be sure to use the media clamps when you set up media.

If you load the media clamps directly before printing after the media setup is complete, the machine may print on the media clamps.

14. Close the front cover.

1. B: Determining the Positions of Media (If [Media Edge Detection]: [Disable])

Use the following procedure to determine the positions of the media when using transparent media or media with high reflectance whose edges cannot be detected, and when [Preferences]>[Media Edge Detection] is set to [Disable].

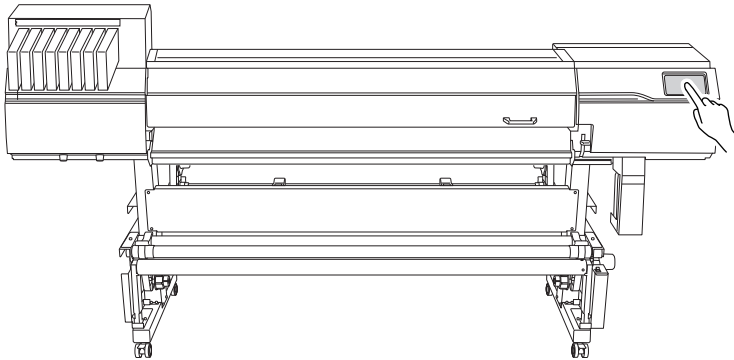

Procedure

1. Tap the operation panel.



2. When instructions appear on the screen, tap the operation panel again.
The machine sub power is switched on.

3. Set the [Skewing Correction Support at Setup].

- (1) Tap .
- (2) Tap [Preferences]>[Skewing Correction Support at Setup].
- (3) Select [Disable] and tap [Save].
- (4) Press  to return to the home screen.

4. Open the front cover.

5. Move the media clamps to the outside of the grit rollers on the left and right edges respectively.

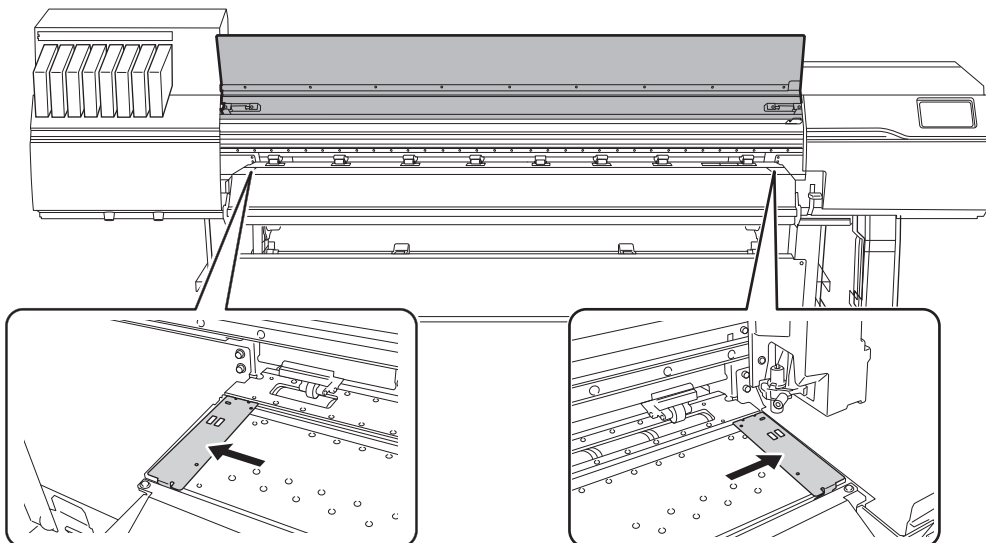

6. Move to the rear of the printer. Release the locking mechanisms of the media holders, and then draw them to the left and right ends respectively.

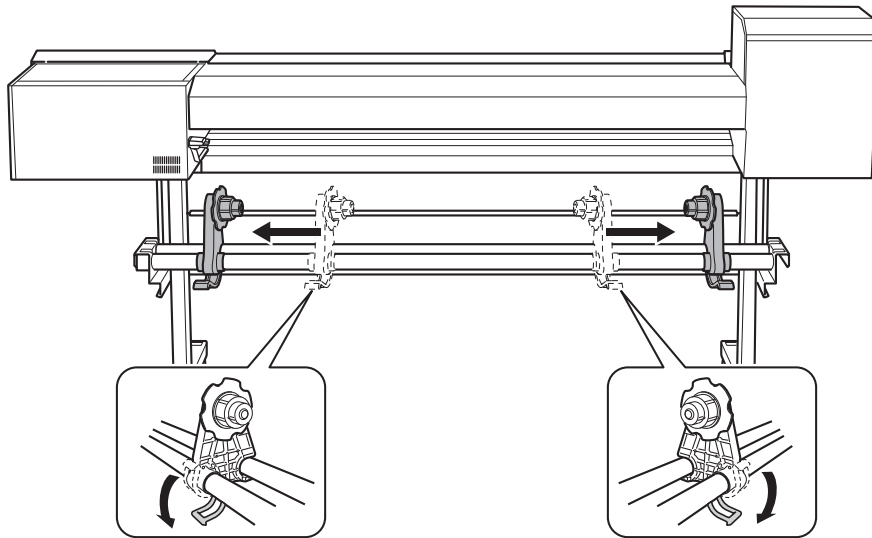

7. Determine the left and right positions of the media with the grit patterns used as the reference. Note the following points when determining the positions.

- Ensure that the left edge of the media is positioned so that it is within the range of the grit pattern of the left edge.
- Ensure that the right edge of the media is positioned so that it is within the range of one of the grit patterns.

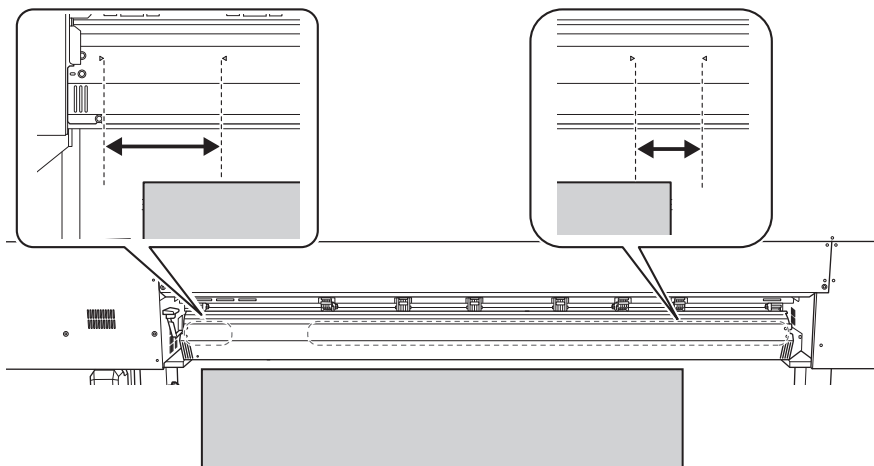

8. Pass the leading edge of the media between the pinch rollers (①) and the grit rollers (②).

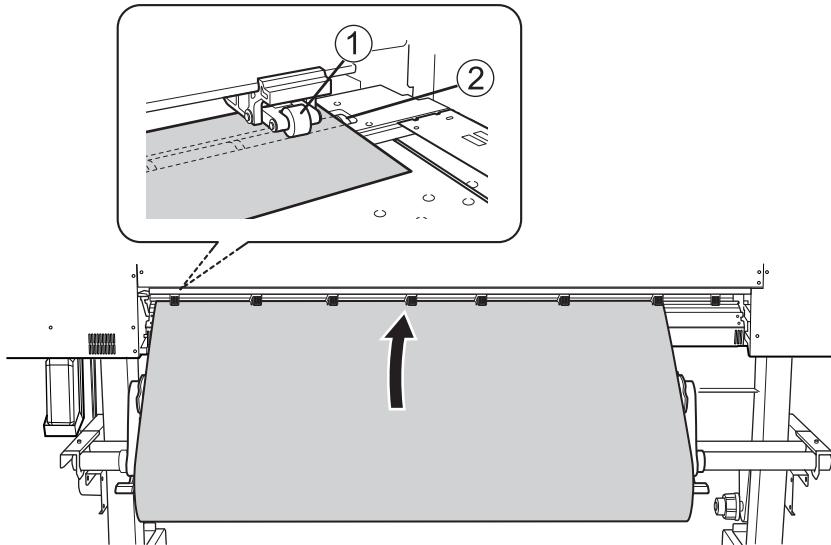

- 9. Lower the loading lever (rear).**
The media is held in place.

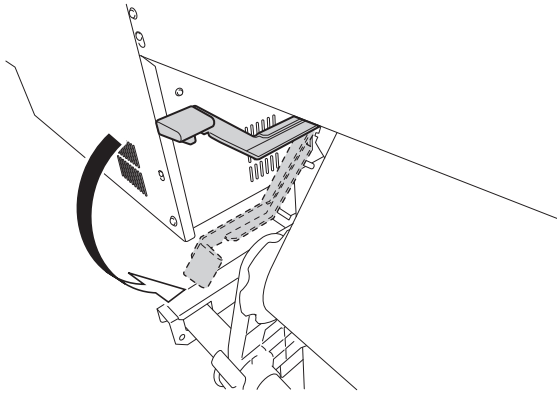

- 10. (Move to the front of the printer.) Gently hold down the media and raise the loading lever (front).**

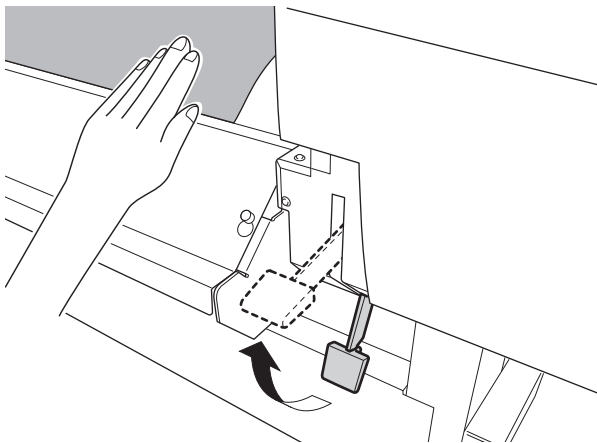

- 11. Make sure both edges of the media are above the grit rollers.**
Be sure to place the right edge of the media on the right-end grit roller.

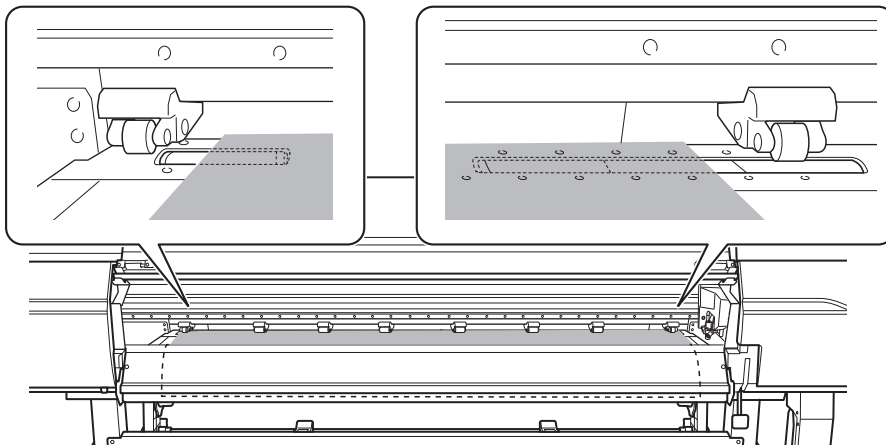

- 12.** Move the left and right pinch rollers, placing them on both edges of the media. Position them approximately 10 mm (0.39 in.) from each edge of the media.

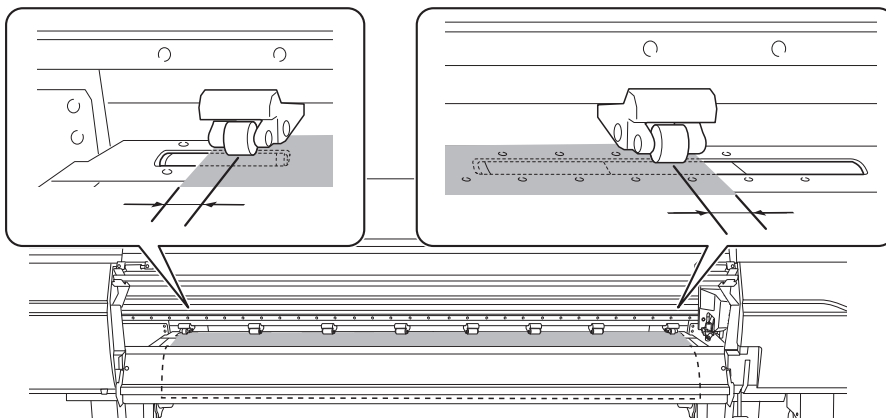

IMPORTANT

Be sure to use the left and right pinch rollers. The force with which the media is pinched varies between the middle pinch rollers and the left and right pinch rollers. Using the middle pinch rollers to pinch the media edges will lead to unstable media feeding.

MEMO

To smoothly move the pinch rollers, push down close to the rail.

- 13.** Move the middle pinch rollers (B) over all the remaining grit rollers (A) covered by the media. There are grit patterns (C) wherever there are grit rollers.

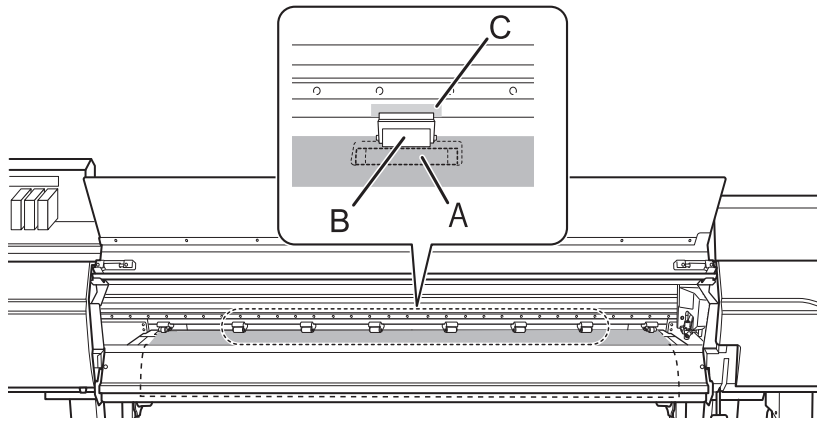

IMPORTANT

- Place the middle pinch rollers over all the grit patterns within the media width. If you have forgotten to place the middle pinch rollers, the media will be skewed during printing or will come loose, which will have an effect on the printing quality.
- The middle pinch roller will not lower onto the three grit rollers from the right end. Place the middle pinch roller on a grit roller other than these three.

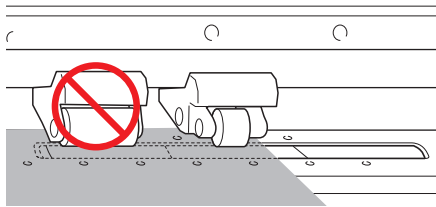

- There may be extra middle pinch rollers depending on the width of the media being used. Move the extra middle pinch rollers to positions where no grit patterns are present. Where no grit patterns are present, the middle pinch rollers will not come down.

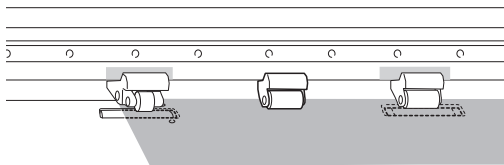

14. Lower the loading lever (front).

The media is held in place.

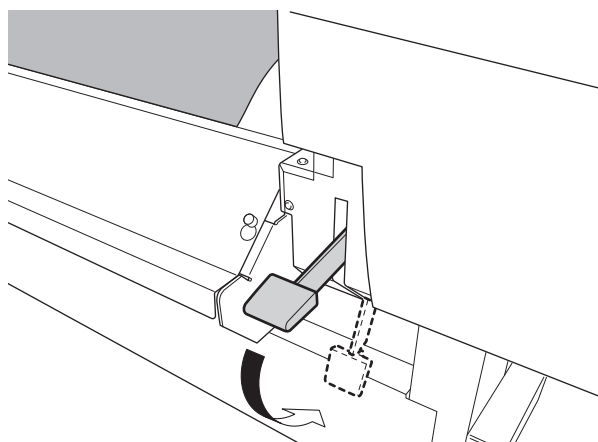

IMPORTANT

If you want to readjust the media position before securing it in place, redo the procedure from step 11.

15. Line up the edges of the media with the centers of the holes of the left and right media clamps.

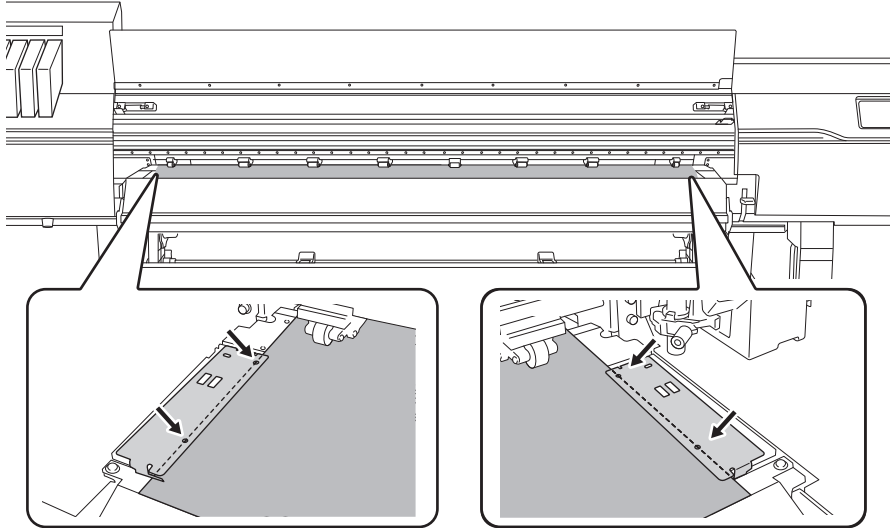
**IMPORTANT**

Be sure to use the media clamps when you set up media.

If you load the media clamps directly before printing after the media setup is complete, the machine may print on the media clamps.

16. Close the front cover.

2. Register the media.

Procedure

1. Tap  [Setup].
2. Select [New].
3. Tap [Next].

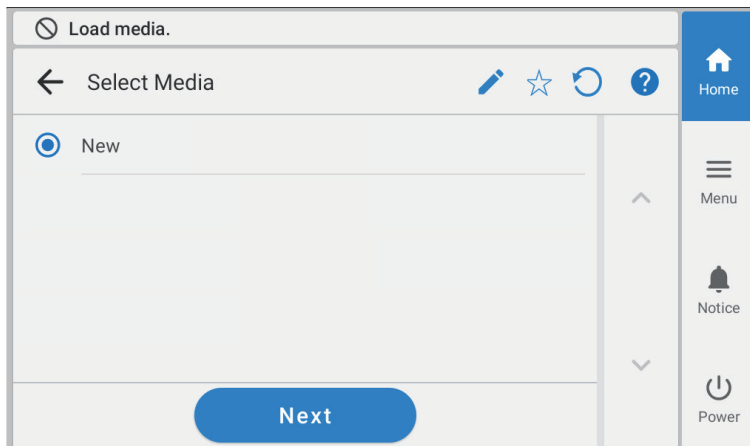

4. Enter a new media name and tap [OK].

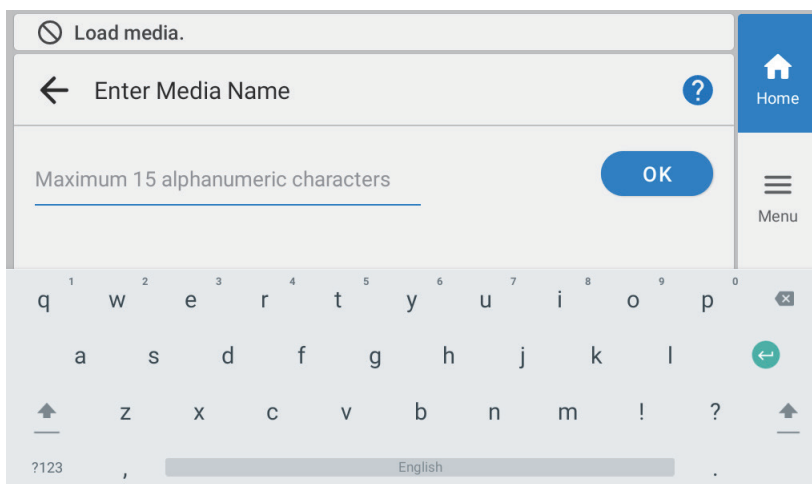

5. Check the name you have entered and tap [Next] if it is correct.
To make corrections, tap the name you entered.
6. The [Setup Method] screen appears. Select whether to use the take-up unit.
7. Tap [Start Setup].
The cutting carriage moves and detects the width of the media and the positions of the media clamps. This operation is called initialization.
8. When [The media could not be detected automatically. Manually set the printing] screen appears, use the following procedure to configure the settings.

MEMO

- This message may appear when media with high reflectance is set up.
- In the case of media where automatic media detection was not possible after new media was registered, the screen automatically changes to the [Printing Area Settings] screen in Step (2).

(1) Tap [OK].

(2) Tap [Change] on the [Printing Area Settings] screen.

The [Set the right edge of the printing area within the area specified by the pinch rollers.] screen appears.

(3) Hold down < or > to move the center of the blade (A) approximately 2 mm (0.08 in.) to the inside (B) from the left edge of the right pinch roller.

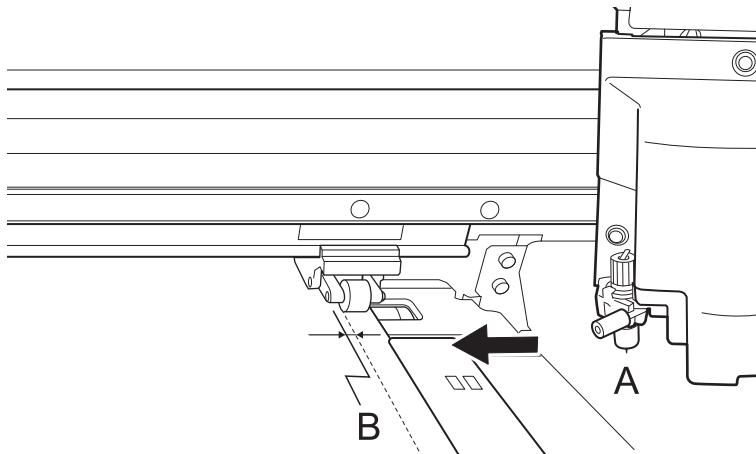

(4) Tap [OK].

The [Set the left edge of the printing area within the area specified by the pinch rollers.] screen appears.

(5) Hold down < or > to move the center of the blade (A) approximately 2 mm (0.08 in.) to the inside (B) from the right edge of the left pinch roller.

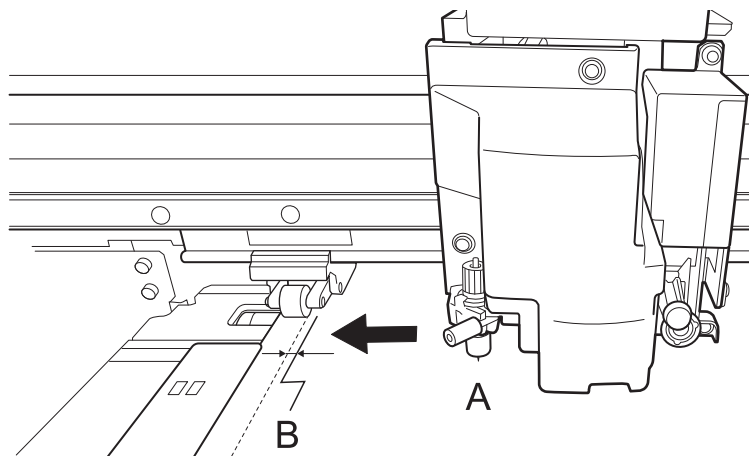

(6) Tap [OK].

The set left and right positions are applied to the [Printing Area (Width)].



(7) Tap [OK].

3. Configuring Settings to Match the Media









To ensure the optimal output according to the media size and type, set the minimal amount of items. All items set here can be set individually as well.

Procedure

1. On the [Select Media Output Type] screen, select the output type and tap [Next].
 - [Print Only/Print & Cut]
Proceed to step 2.
 - [Cut Only]
Switch to the [Multi Sensor Adjustment] screen. Tap [Execute] to perform automatic adjustment, then tap [OK]. This completes the settings for [Cut Only].

2. On the [Heater Temperature] screen, adjust the [Print Heater] and [Dryer] temperatures.
 - If this is not necessary, tap [Next].
 - Follow the procedure below to make changes.
 - a. Tap  or  to set the [Print Heater] or [Dryer] temperature.
 - b. Tap [Next].

3. Use the [Print Head Height] screen to adjust the print head height.
 - If this is not necessary, tap [Next].
 - Follow the procedure below to make adjustments.
 - a. Tap [Change]
 - b. Open the front cover.
 - c. Move the height-adjustment lever to adjust the head height.
 - d. Close the front cover.
 - e. Tap [OK].
 - f. Tap [Next].
 For details on this work, refer to [Changing the Print Head Height\(P. 180\)](#).

4. Set the [Printing Test] and [Output Start Location] on the [Nozzle Drop-out Test] screen.
 - Proceed to step 5 if this step is not necessary.
 - Follow the procedure below to set [Output Start Location].
 - a. Tap [Output Start Location]>[Change].
 - b. Tap .
 - The cutting carriage moves to the current base point.
 - c. Tap     and move the cutter center to the position where you want to start cutting.
Tap  or  to move the media in the feed direction (forward-back). Tap  or  to move the cutting carriage in the scan direction (left-right).

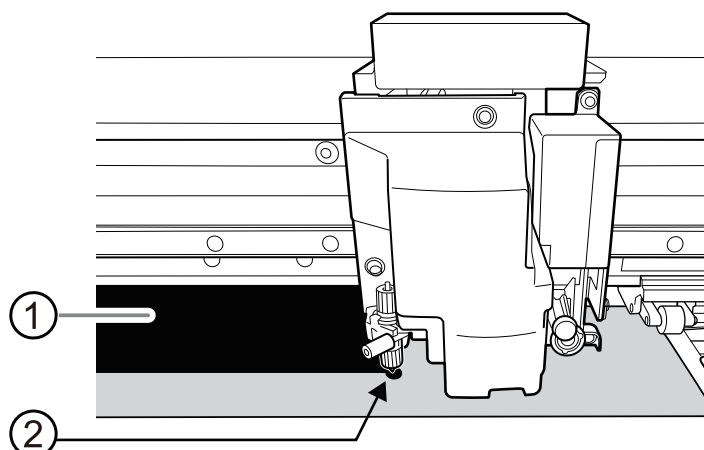

- ①: Printing area
- ②: Base point (right edge of the printing area)

d. Once the position has been decided, tap **[Set Base Point Here]** to confirm it.

The base point position is updated.

- Follow the procedure below to perform **[Printing Test]**.

Tap **[Printing Test]**>**[Execute]**. For details on what to do after the printing test, refer to [Normal Cleaning Method\(P. 318\)](#).

5. Tap **[Next]**.

6. On the **[Select Media Adjustment Method]** screen, select the adjustment method.

Here, the media feed correction for reducing horizontal bands and the correction of the landing position of the ink will be adjusted.

MEMO

- **[Simple Correction (Auto)]** is the recommended adjustment. You can determine the correction values with **[Detailed Correction (Manual)]**.

- Follow the procedure below to make automatic adjustments.

- a. Tap **[Simple Correction (Auto)]**>**[Next]**.
- b. Tap **[Execute]** on the **[Batch Automatic Correction]** screen.

Check the printing area required for the printing test before executing the test.

On successful completion of automatic adjustment, the home screen appears. This completes the settings.

For more information, refer to [Automatically Making Required Adjustments\(P. 175\)](#).

- Follow the procedure below to make manual adjustments.

- a. Tap **[Detailed Correction (Manual)]**>**[Next]**.
- b. Tap **[Execute]** on the **[Multi Sensor Adjustment]** screen.

Adjust the reading sensor to the optimal condition. If the adjustment failed, respond to the failure according to the information in [Correcting the Reading Sensor\(P. 220\)](#).

- c. Tap **[Next]**.

- d. Tap **[Printing Test]**>**[Execute]** on the **[Detailed Feed Correction (Manual)]** screen. Check the printing area required for the printing test before executing the test.

Set the correction values from the printing test result. For more information, refer to [Manual Adjustment: Reducing Horizontal Bands \(Feed Correction\)\(P. 176\)](#).

- e. Tap [Save and Proceed].
- f. Tap [Printing Test]>[Execute] on the [Detailed Media Gap Adjustment (Manual)] screen.
Set the correction values from the printing test result. For more information, refer to [Manual Adjustment: Adjusting the Misalignment of the Ink Landing Position \(Media Gap Adjustment\)\(P. 178\)](#).
- g. Tap [Save and Exit].

IMPORTANT

- When [Take-up] is set to [Disabled], rewind the media from the take-up unit when printing and cutting or just cutting to slacken the media. If sufficient media is not wound on the paper tube immediately after setup, this operation may not be performed well, lowering the cutting quality and preventing continued take-up. When performing cutting immediately after attaching the media to the paper tube, first feed enough media to carry out take-up a few times and set the base point.
- When [Take-up] is set to [Enabled], if sufficient media is not wound on the paper tube, this operation may not be performed well, lowering the cutting quality and preventing continued take-up. Take up the media at least halfway around the paper tube before setting the base point.

This completes the setup.

Setup of Registered Media

CAUTION

Do not touch the dancer roller needlessly.

The media take-up unit and feeder may move suddenly, which may result in injury.

Setup of Roll Media

Load the roll media on the printer. When the loading is finished, [Output possible.] is displayed as the status. This work is referred to as "Setup of Media."

CAUTION

Load the roll media correctly.

Otherwise the media may fall and cause injury.

CAUTION

The roll media is approximately 45 kg (99 lb.) (54-inch model: 35 kg [77 lb.]).

To avoid injury, handle the roll media with care.

CAUTION

Never load media that weighs over 45 kg (99 lb.) (54-inch model: 35 kg [77 lb.]).

The machine may fail to withstand the weight and tip over or cause the media to fall.

1. Installing the Media on the Media Holders

⚠ WARNING

Handling roll media is an operation that must be performed by 2 persons or more, and care must be taken to prevent falls.

Attempting to lift heavy media in a manner that taxes your strength may cause physical injury. Also, if dropped, such items may cause injury.

MEMO

The media holders of this machine are designed to be used with a paper tube (core) with an inner diameter of 2 inches or 3 inches.

Procedure

1. Tap the operation panel.

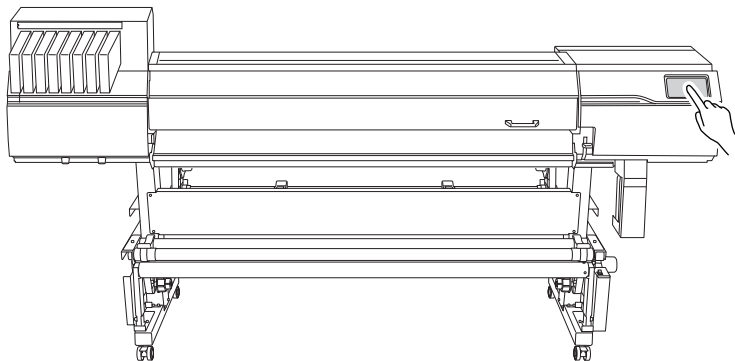

2. When instructions appear on the screen, tap the operation panel again.

The machine sub power is switched on.

3. When using a take-up unit, use the following procedure to set it.

Make sure the following settings match the loading method and output method of the actual media.

The settings will have to be changed from the defaults when:

- When using weak media.
- Taking-up the media with inward curl.
- Taking up the media during cutting process in the Print & Cut mode

- (1) Tap .
- (2) Tap [Preferences]>[Take-up].
- (3) Tap [Take-up during Cutting].
- (4) Select [Enabled] or [Disabled].

[Enabled]	The media is taken up during cutting while slack is being created. This prevents the media from sticking to the floor. Make sure the media is taken up at least halfway around the paper tube beforehand.
[Disabled]	The media is taken up after all cutting finishes.

MEMO

- Default setting: [Disabled]
- [Enabled] cannot be performed in the following situations:
 - [Blade Adjustment]>[Printing Test]
 - [Print & Cut Position Adjustment]>[Printing Test 1(Misalignment Check)]/[Printing Test 2(Correction Values)]
 - [Crop Cut Position Adjustment]>[Printing Test 1(Misalignment Check)]/[Printing Test 2(Correction Values)]

IMPORTANT

When [Preferences]>[Take-up]>[Enabled] is set, to preserve cut quality, the speed may be limited to the optimum speed for [Cutting Speed] and [Rise Movement Speed] depending on the set media.

[P. 200 Fine-tuning the Cutting Conditions](#)

- (5) Tap [Save].
- (6) Tap [Take-up Method].
- (7) Select [Loose Winding] or [Tension Winding].

[Loose Winding]	The media is taken up with some slack. This is suited to PVC and other such stiff or slippery media.
[Tension Winding]	The media is stretched and taken up. This is suited to tarpaulin and other such weak media and media that does not slip easily. Even if [Tension Winding] is set, if [Enabled] is enabled, the media is taken up while slack is being created.

MEMO

- Default setting: [Loose Winding]

- (8) Tap [Save].
- (9) Tap [Take-up Direction].
- (10) Select [Backward] or [Forward].

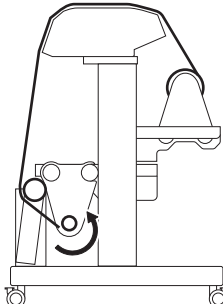
[Forward]	<p>The media is taken up onto the paper tube with the printed surface on the outside.</p> 
-----------	---

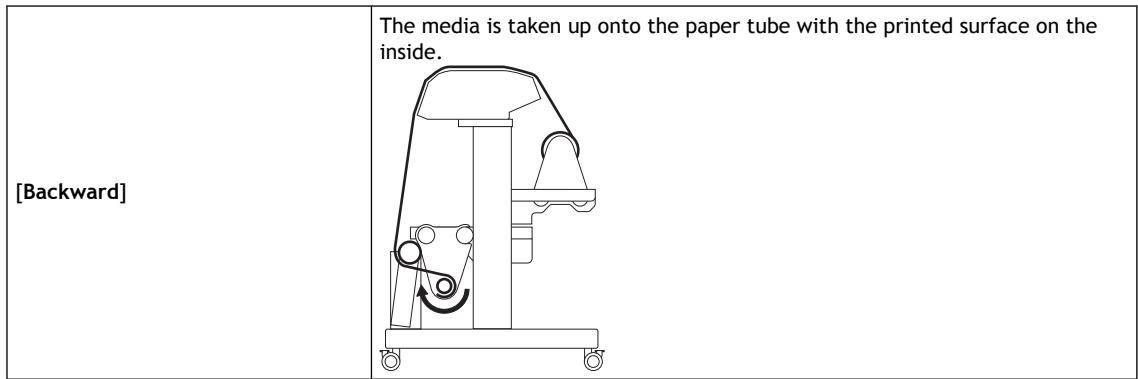

MEMO

- Default setting: [Forward]

(11) Tap [Save].

(12) Tap  to return to the home screen.

4. Check that the dancer roller has lowered toward the rear.

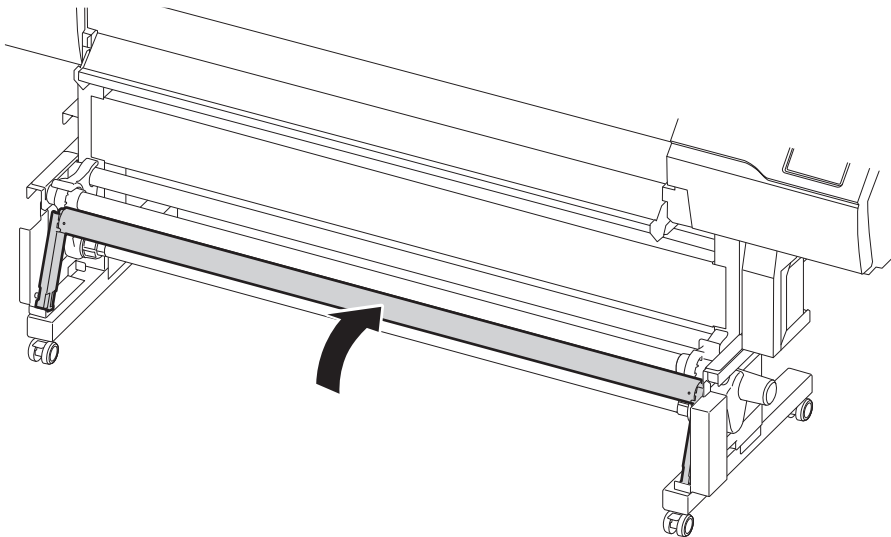

5. Open the front cover.

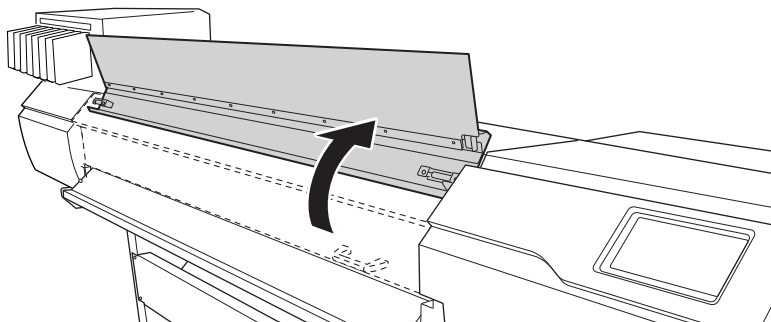

6. Move the media clamps to the outside of the grit rollers on the left and right edges respectively.

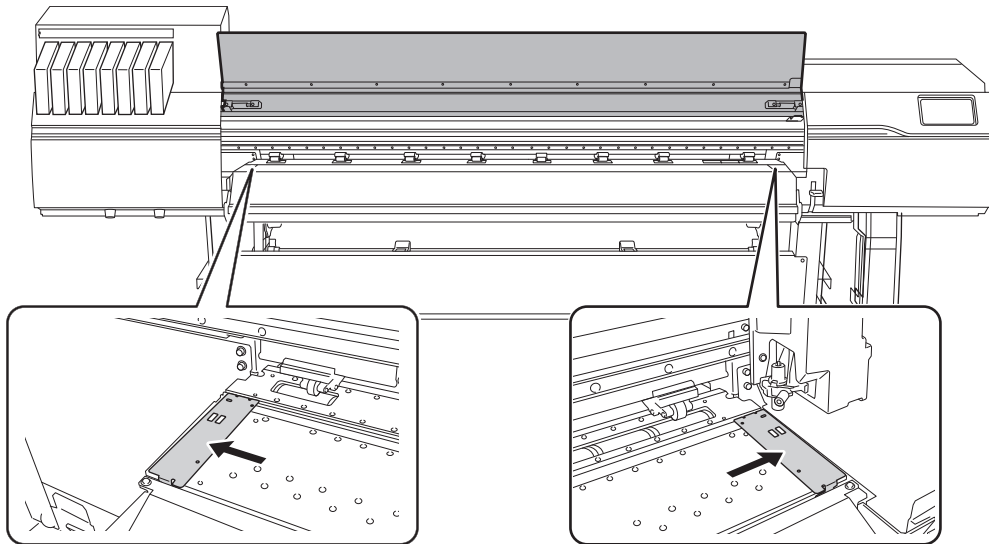

7. Release the locking mechanisms of the media holders, and then draw them to the left and right ends respectively.

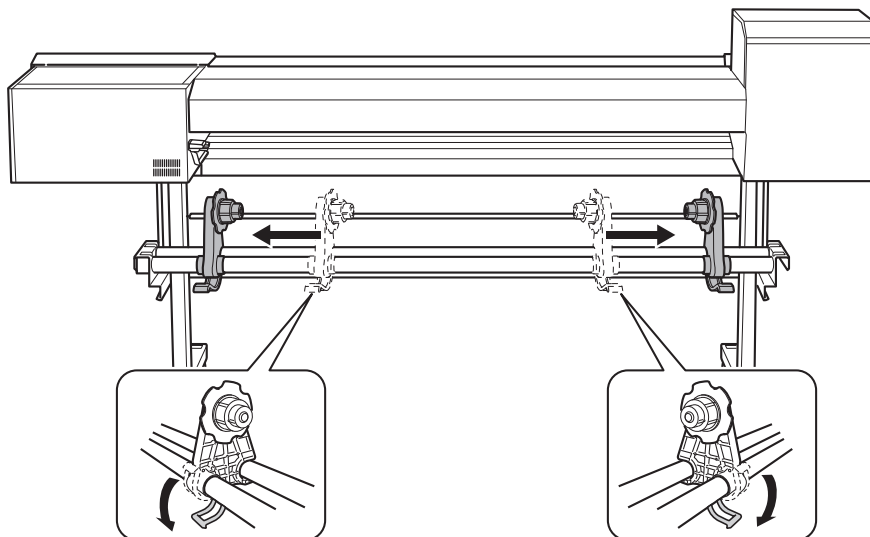

8. Place the media on the machine.

IMPORTANT

Do not leave media on the media stays or the shafts for a long period of time. The media may become deformed. Exercise caution.

- Roll media with an outer diameter of 220 mm (8.66 in.) or less
Place the media stays at positions that are 1/4 the length of the media from each end of the media, and then load the media.

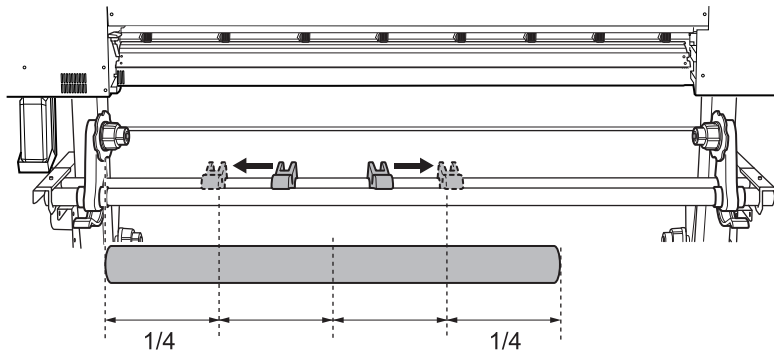

- Roll media with an outer diameter exceeding 220 mm (8.67 in.)
 - a. Rotate the media stays to draw them to the media holders.

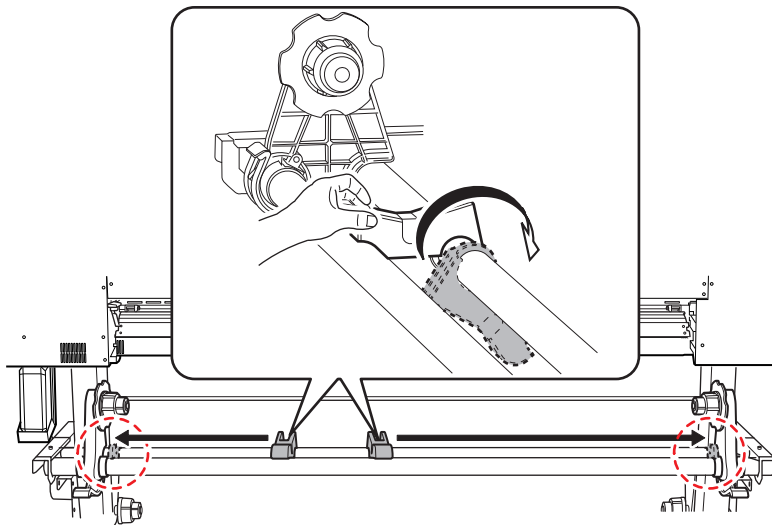

- b. Place the media directly between the two shafts.

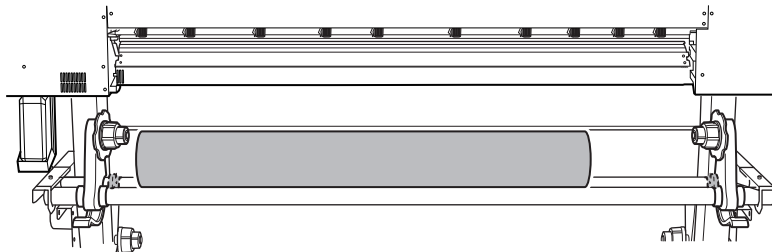

9. Fit the paper tube (core) of the media onto the end cap of the left media holder.

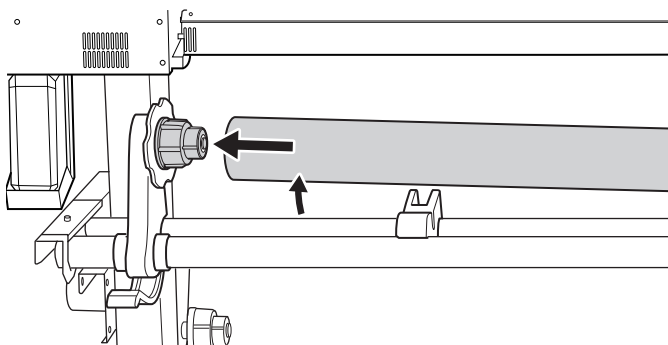

10. Move the right media holder to fit its end cap onto the paper tube (core) of the media.
Fit the paper tube onto the media holders securely to prevent the media from moving easily.

IMPORTANT

Do not secure the media holders in place just yet.

In the following procedure, you will adjust the positions of the media holders before securing them in place. Do not secure them in place just yet.

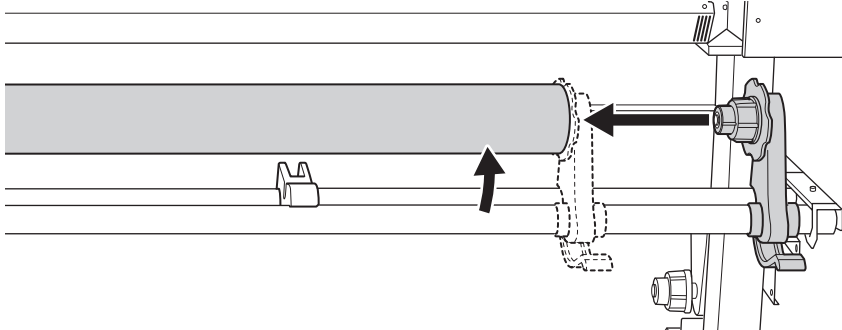

The next operation to perform varies depending on the media type and the Preferences. Proceed as shown below.

- For general media: [2. A: Determine the positions of the media.](#) (P. 84)
- For transparent media or if [Preferences]>[Media Edge Detection] is set to [Disable]: [2. B: Determining the Positions of Media \(If \[Media Edge Detection\]: \[Disable\]\)](#) (P. 89)

2. A: Determine the positions of the media.



This section describes how to use the suction fan to prevent media skewing.

Because the suction fan does not operate, the following procedure cannot be used to load media when using transparent media or media with high reflectance whose edges cannot be detected, or when [Disable] is set for [Preferences]>[Media Edge Detection]. In these cases, refer to [2. B: Determining the Positions of Media \(If \[Media Edge Detection\]: \[Disable\]\)\(P. 89\)](#).

By default, [Skewing Correction Support at Setup] is set to [Enable].

Procedure

1. Set the [Skewing Correction Support at Setup].

- (1) Tap .
- (2) Tap [Preferences]>[Skewing Correction Support at Setup].
- (3) Select [Enable] and tap [Save].
- (4) Press  to return to the home screen.

2. Determine the left and right positions of the media with the grit patterns used as the reference.

Note the following points when determining the positions.

- Hold the media holders from the outside and move them.
- Ensure that the left edge of the media is positioned so that it is within the range of the grit pattern of the left edge.
- Ensure that the right edge of the media is positioned so that it is within the range of one of the grit patterns.

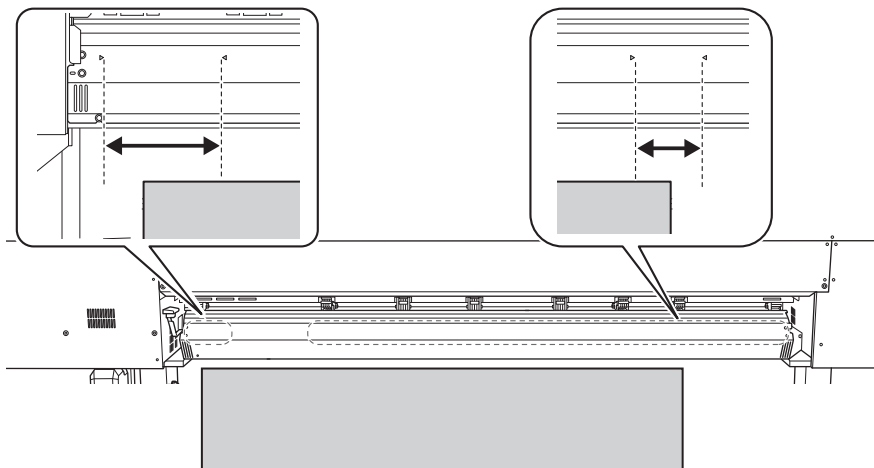

WARNING

Do not hold places other than those instructed. Do not move the media by holding it directly.

Doing so may cause the media to fall off the media holder and cause injury.

IMPORTANT

Firmly decide the left and right side positions of the media at this point.

After this procedure is completed, if the left and right side positions do not fit the proper positions when securing the media with pinch rollers, you will have to go back to this step to redo this procedure. If you just

hold the media to readjust its position forcibly, the media will be skewed during printing, which will have an adverse effect on the printing results.

3. Secure the media holders.

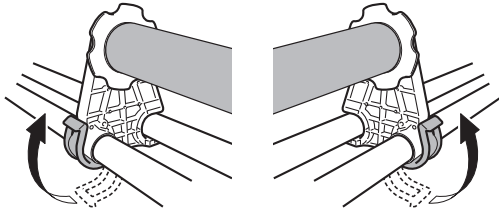

4. Use the following procedure to load the media.

Doing so will prevent media skewing.

- (1) Pass the leading edge of the media between the pinch rollers (①) and the grit rollers (②).

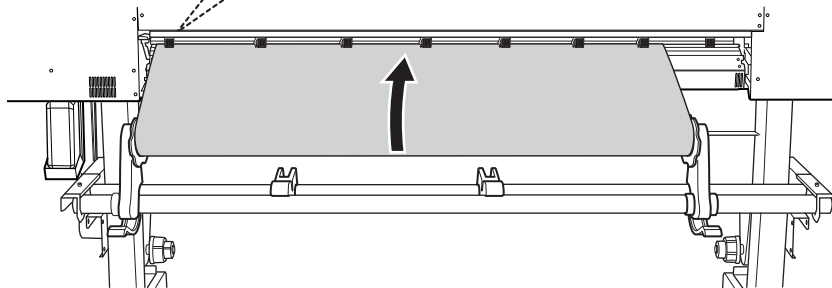
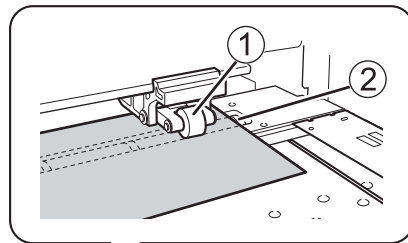

- (2) Feed the media until you hear a beep, and then additionally feed approximately 20 cm (7.87 in.) of the media.

You will hear a beep. Approximately 5 seconds later, you will hear two beeps, and then the suction fan will activate. While this fan is operating, the position of the media will be maintained even if you remove your hands from it.

- (3) Hold the media holder flange, turning it in the take-up direction to eliminate the slack in the media.

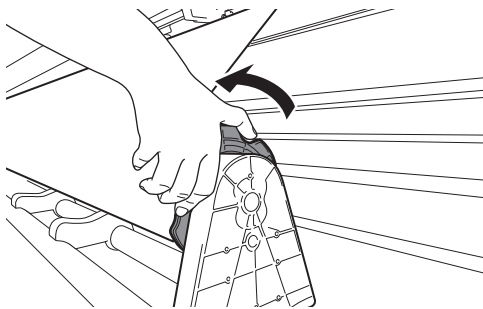

- (4) Once the media is taut, additionally take up approximately 10 cm (3.94 in.) of media.

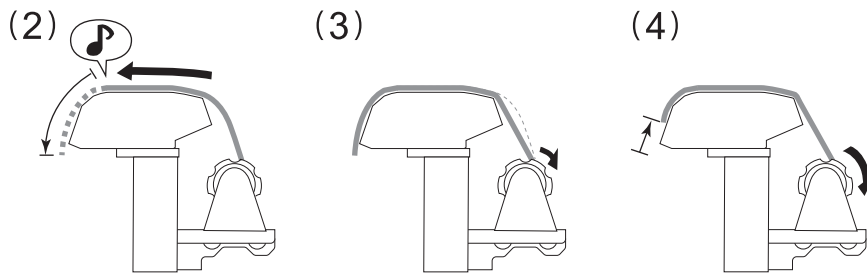

MEMO

If you take up too much media, you will hear two short beeps and the suction fan will stop. Take up the media, and then redo the procedure from Step (1).

5. (Move to the front of the printer.) Make sure both edges of the media are above the grit rollers. Be sure to place the right edge of the media on the right-end grit roller.

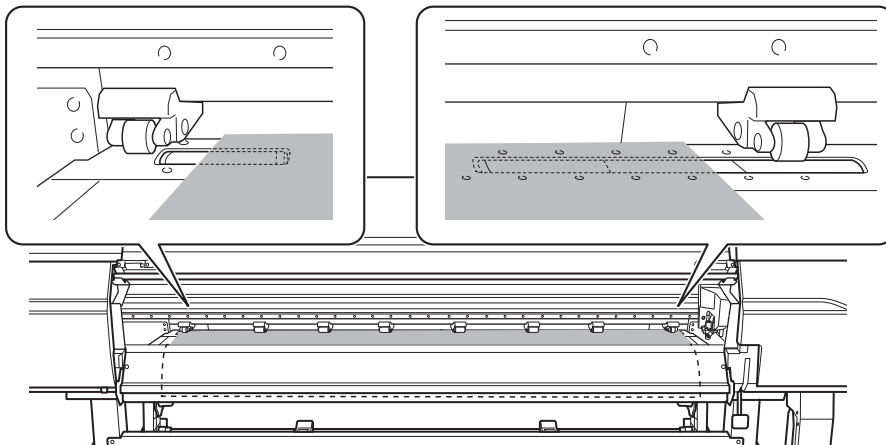

6. Move the left and right pinch rollers, placing them on both edges of the media. Position them approximately 10 mm (0.39 in.) from each edge of the media.

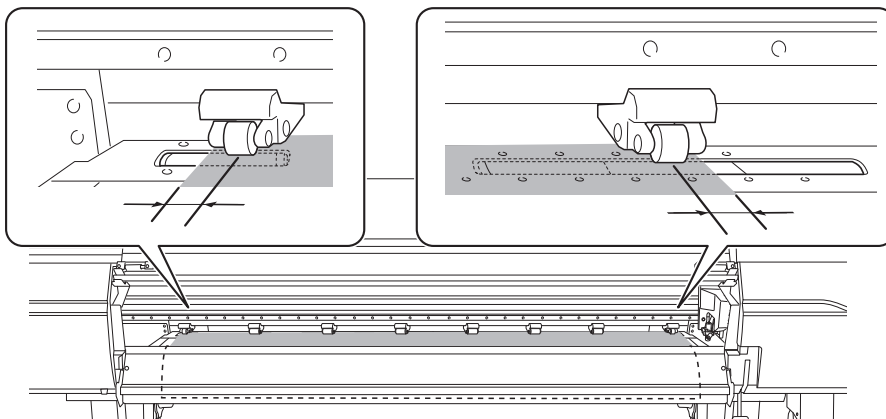

IMPORTANT

- Be sure to use the left and right pinch rollers. The force with which the media is pinched varies between the middle pinch rollers and the left and right pinch rollers. Using the middle pinch rollers to pinch the media edges will lead to unstable media feeding.
- If you want to readjust the media position, return to the back of the printer, release the media holders, and then redo the procedure from Step 2. If you just stand at the front of the printer and hold the media to

readjust its position forcibly, the media will be skewed during printing or will come loose, which will affect the printing quality.

MEMO

To smoothly move the pinch rollers, push down close to the rail.

7. Move the middle pinch rollers (B) over all the remaining grit rollers (A) covered by the media. There are grit patterns (C) wherever there are grit rollers.

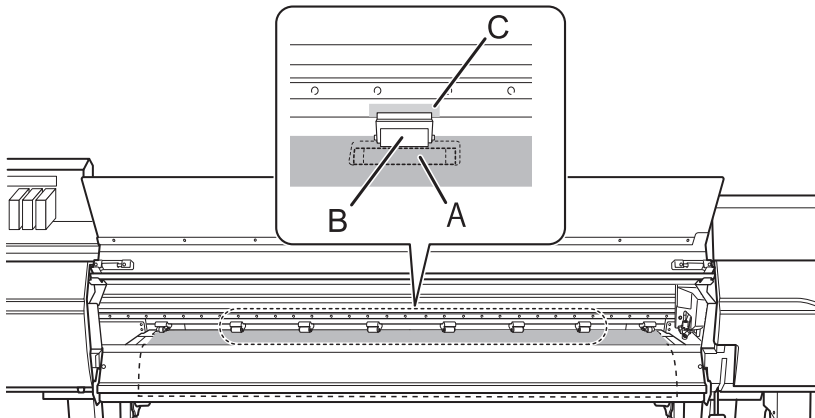

IMPORTANT

- Place the middle pinch rollers over all the grit patterns within the media width. If you have forgotten to place the middle pinch rollers, the media will be skewed during printing or will come loose, which will have an effect on the printing quality.
- The middle pinch roller will not lower onto the three grit rollers from the right end. Place the middle pinch roller on a grit roller other than these three.

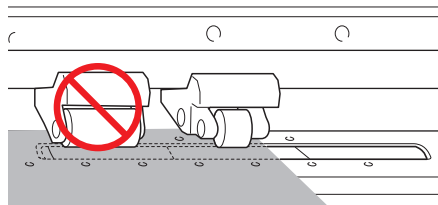

- There may be extra middle pinch rollers depending on the width of the media being used. Move the extra middle pinch rollers to positions where no grit patterns are present. Where no grit patterns are present, the middle pinch rollers will not come down.

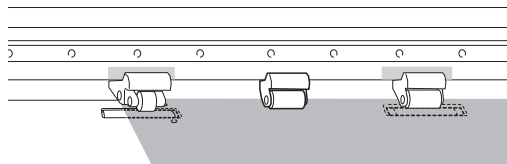

8. Lower the loading lever (front). The media is held in place.

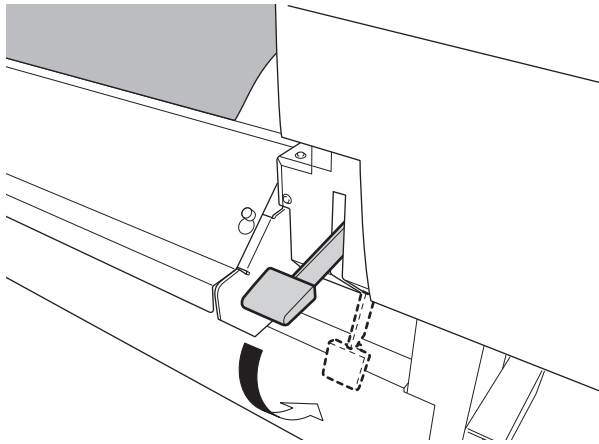

IMPORTANT

If you want to readjust the media position, return to the back of the printer, release the media holders, and then redo the procedure from Step 2. If you just stand at the front of the printer and hold the media to readjust its position forcibly, the media will be skewed during printing or will come loose, which will affect the printing quality.

9. Line up the edges of the media with the centers of the holes of the left and right media clamps.

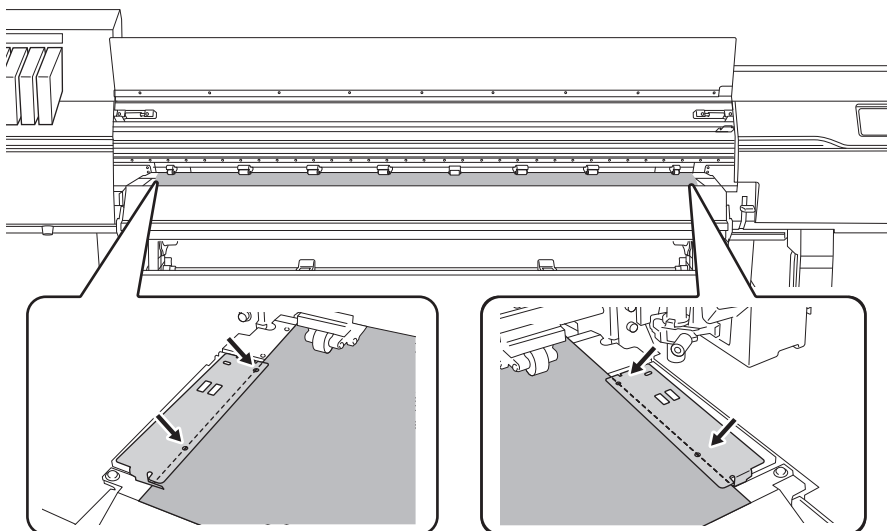

IMPORTANT

Be sure to use the media clamps when you set up media.
If you load the media clamps directly before printing after the media setup is complete, the machine may print on the media clamps.



10. Close the front cover.

2. B: Determining the Positions of Media (If [Media Edge Detection]: [Disable])

Use the following procedure to determine the positions of the media when using transparent media or media with high reflectance whose edges cannot be detected, and when [Preferences]>[Media Edge Detection] is set to [Disable].

Procedure

1. Set the [Skewing Correction Support at Setup].

- (1) Tap .
- (2) Tap [Preferences]>[Skewing Correction Support at Setup].
- (3) Select [Disable] and tap [Save].
- (4) Press  to return to the home screen.

2. Determine the left and right positions of the media with the grit patterns used as the reference.

Note the following points when determining the positions.

- Hold the media holders from the outside and move them.
- Ensure that the left edge of the media is positioned so that it is within the range of the grit pattern of the left edge.
- Ensure that the right edge of the media is positioned so that it is within the range of one of the grit patterns.

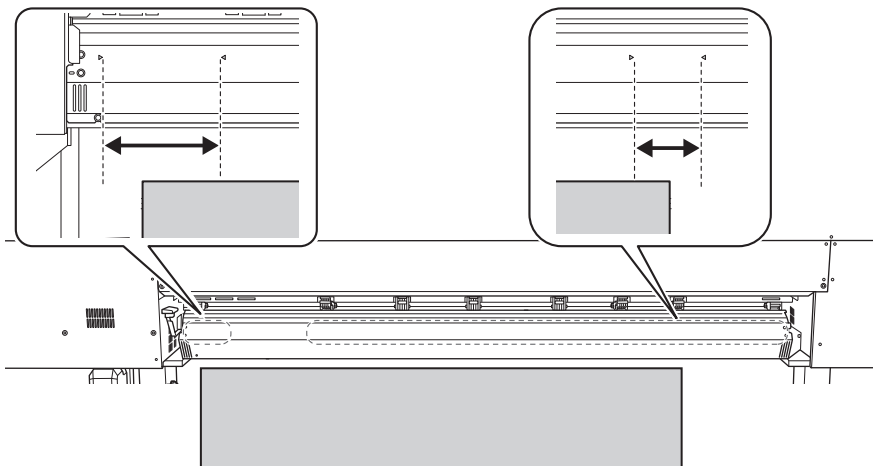

WARNING

Do not hold places other than those instructed. Do not move the media by holding it directly.

Doing so may cause the media to fall off the media holder and cause injury.

IMPORTANT

Firmly decide the left and right side positions of the media at this point.

After this procedure is completed, if the left and right side positions do not fit the proper positions when securing the media with pinch rollers, you will have to go back to this step to redo this procedure. If you just hold the media to readjust its position forcibly, the media will be skewed during printing, which will have an adverse effect on the printing results.

3. Secure the media holders.

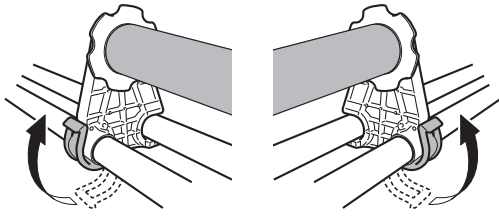

4. Pass the leading edge of the media between the pinch rollers (①) and the grit rollers (②).

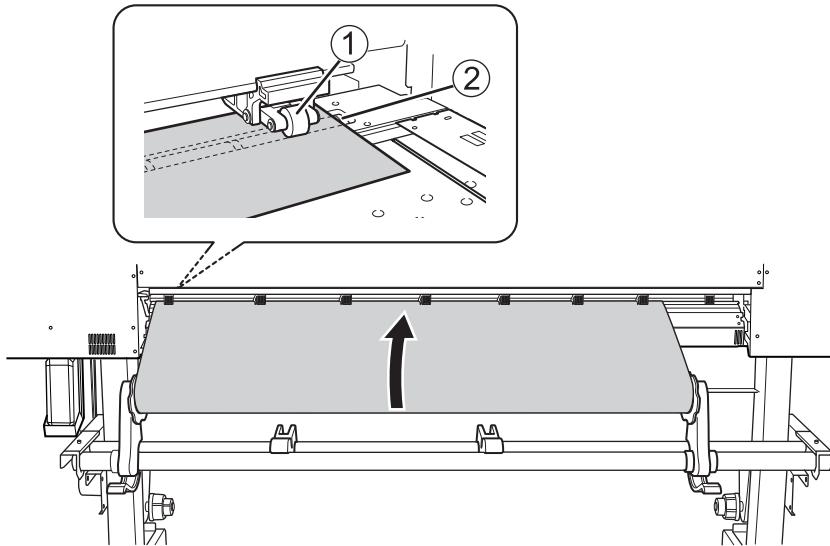

5. Lower the loading lever (rear).
The media is held in place.

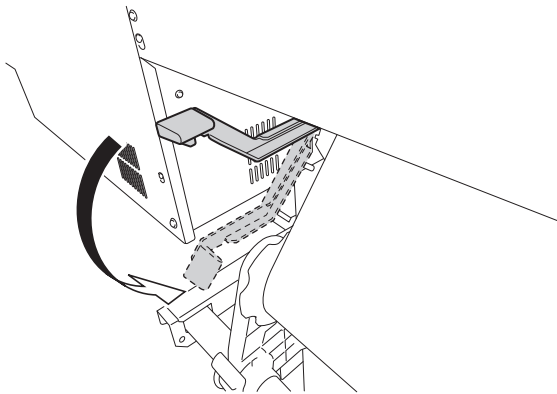

6. (Move to the front of the printer.) Gently hold down the media and raise the loading lever (front).

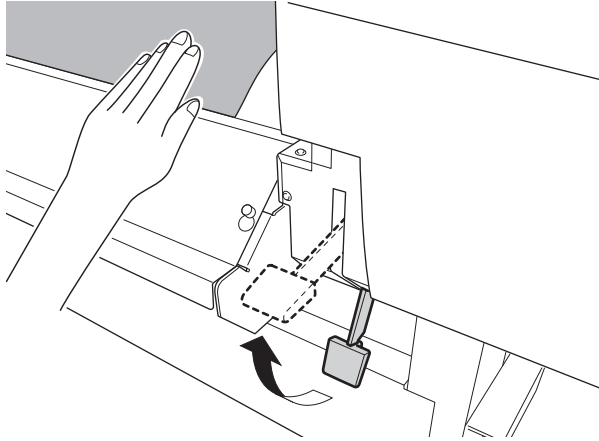

- 7.** Pull out the media over the apron.

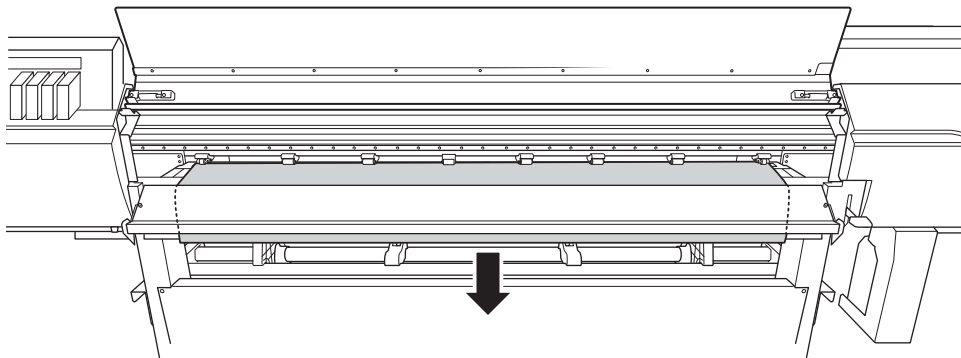

- 8.** Make sure both edges of the media are above the grit rollers.
Be sure to place the right edge of the media on the right-end grit roller.

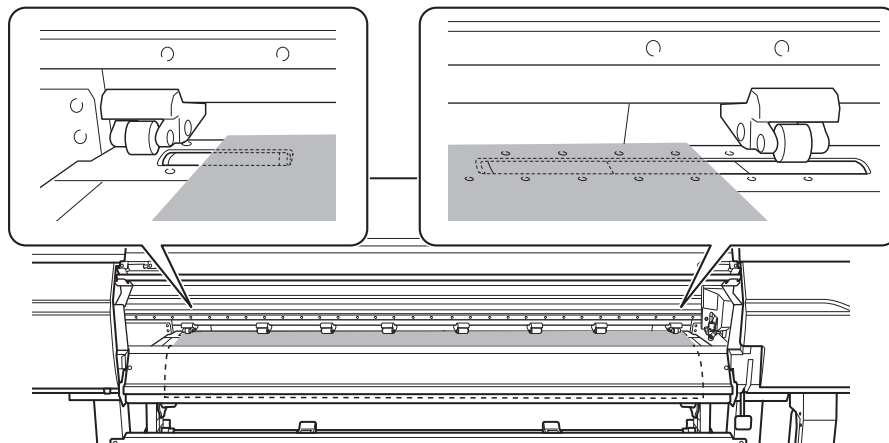

- 9.** Move the left and right pinch rollers, placing them on both edges of the media.
Position them approximately 10 mm (0.39 in.) from each edge of the media.

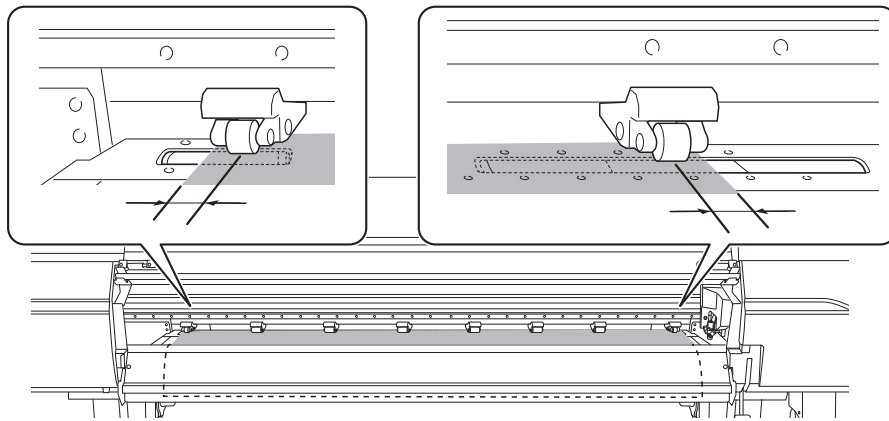

IMPORTANT

- Be sure to use the left and right pinch rollers. The force with which the media is pinched varies between the middle pinch rollers and the left and right pinch rollers. Using the middle pinch rollers to pinch the media edges will lead to unstable media feeding.
- If you want to readjust the media position, return to the back of the printer, release the media holders, and then redo the procedure from Step 2. If you just stand at the front of the printer and hold the media to readjust its position forcibly, the media will be skewed during printing or will come loose, which will affect the printing quality.

MEMO

To smoothly move the pinch rollers, push down close to the rail.

- 10. Move the middle pinch rollers (B) over all the remaining grit rollers (A) covered by the media.**
There are grit patterns (C) wherever there are grit rollers.

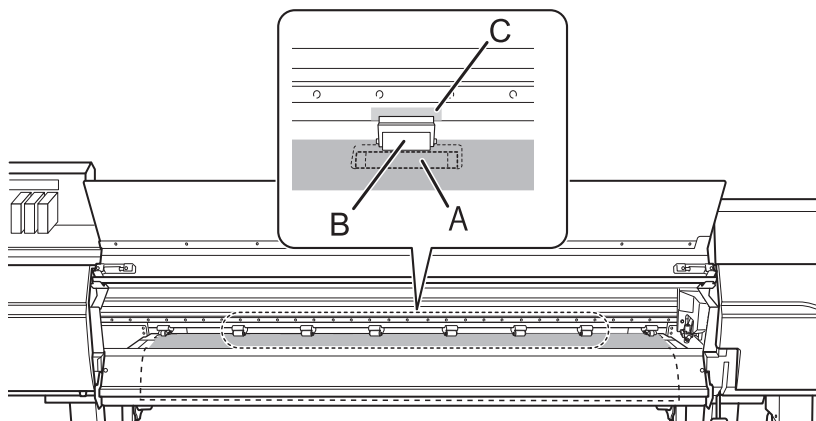

IMPORTANT

- Place the middle pinch rollers over all the grit patterns within the media width. If you have forgotten to place the middle pinch rollers, the media will be skewed during printing or will come loose, which will have an effect on the printing quality.
- The middle pinch roller will not lower onto the three grit rollers from the right end. Place the middle pinch roller on a grit roller other than these three.

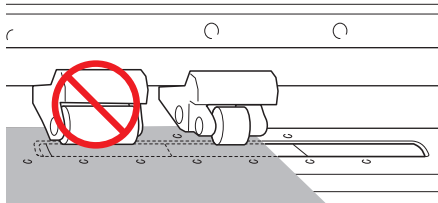

- There may be extra middle pinch rollers depending on the width of the media being used. Move the extra middle pinch rollers to positions where no grit patterns are present. Where no grit patterns are present, the middle pinch rollers will not come down.

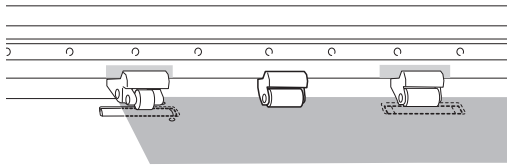

11. Hold the media at the center and pull it out, being sure to keep it straight and all areas of the media to be taut.

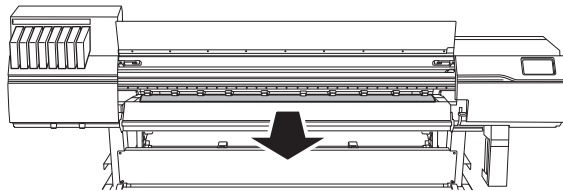

Good

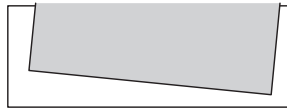

Not good

12. Lower the loading lever (front).
The media is held in place.

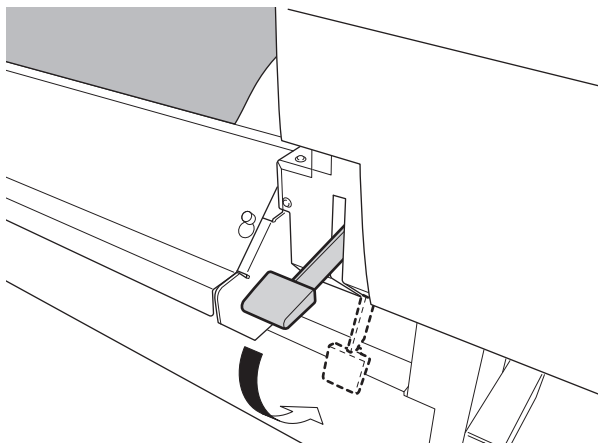

13. Line up the edges of the media with the centers of the holes of the left and right media clamps.

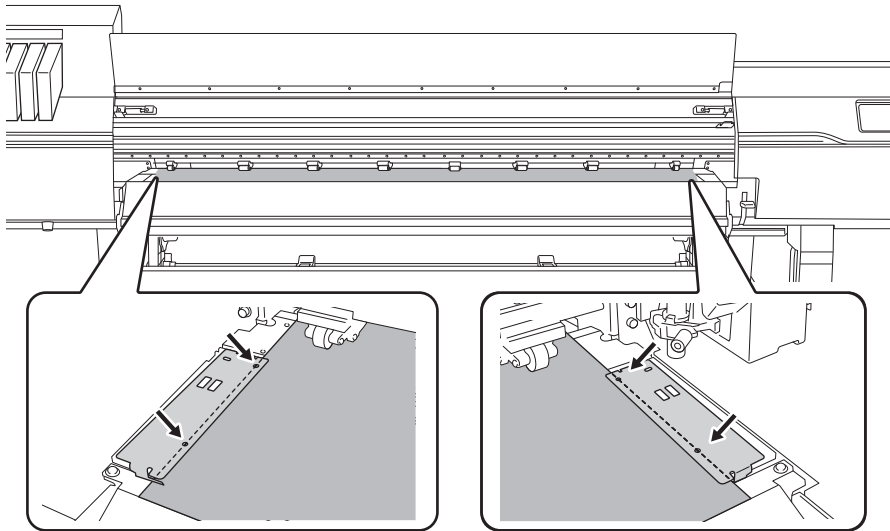

IMPORTANT

Be sure to use the media clamps when you set up media.

If you load the media clamps directly before printing after the media setup is complete, the machine may print on the media clamps.

14. Close the front cover.

3. Select the media.

Procedure

1. Tap  [Setup].

The registered media is displayed in a list.

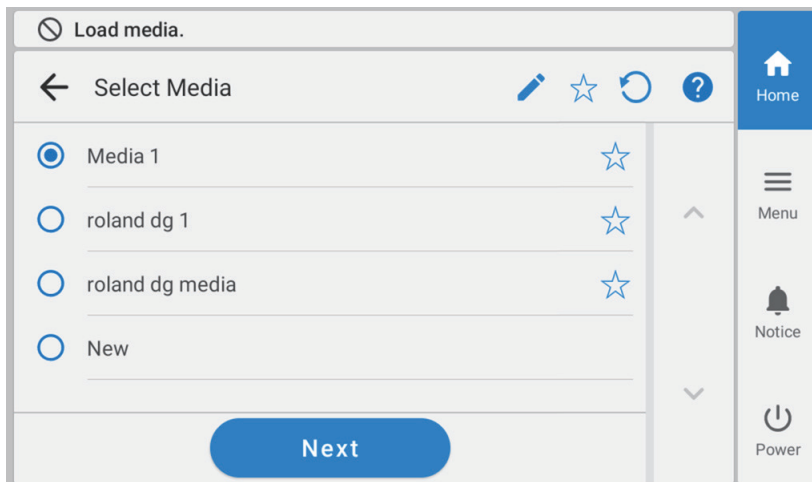

2. Select the media to use.



MEMO

You can search for media in the media list by keyword and register media as favorites. The media list can also be set to show only media registered as favorites. Keyword searching and favorites registration can be used at the same time.

- **Searching for keywords in the media list**

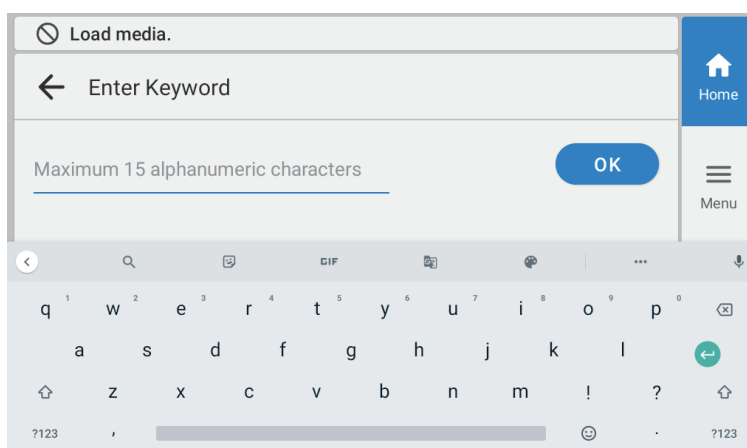
1. Tap .
2. Enter the media to search for.
Searching for partial matches instead of exact matches is also possible.



3. Tap [OK].
Media filtered according to the keywords will be displayed.
 4. Select the media to use from the search results.
- **Registering media to favorites and showing only media registered as favorites**
Tap  for the media to register it to favorites.
The icon for the favorited media will be displayed as .

To show only media registered as favorites, tap the icon indicated below.

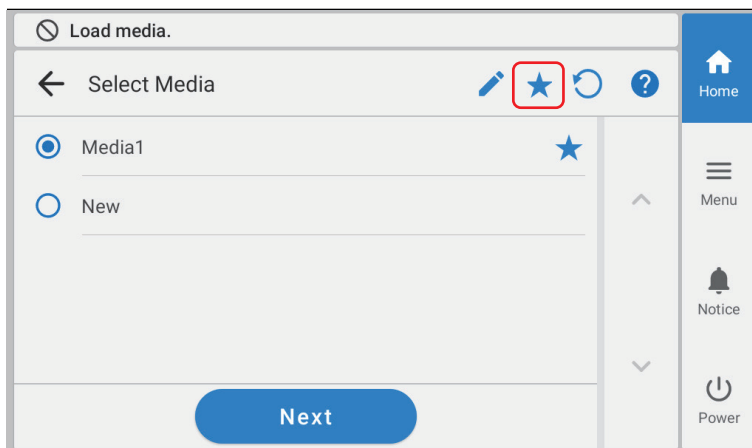

To reset the keyword search or favorites registration, tap .

When using both the keyword search and favorites registration, each function can also be reset individually.

To reset the keyword search, tap  to delete the keyword.

To reset the favorites registration, tap  for the media you want to reset.

3. Tap [Next].

4. The [Setup Method] screen appears. Select whether to use the take-up unit.

5. Tap [Start Setup].

The cutting carriage moves and detects the width of the media and the positions of the media clamps. This operation is called initialization.

6. When [The media could not be detected automatically. Manually set the printing] screen appears, use the following procedure to configure the settings.

MEMO

- This message may appear when media with high reflectance is set up.
- If automatic media detection is not possible and the printing area is set manually when new media is registered, the screen automatically changes to the [Printing Area Settings] screen in Step (3).

(1) Tap [OK].

(2) Enter a new media name and tap [OK].

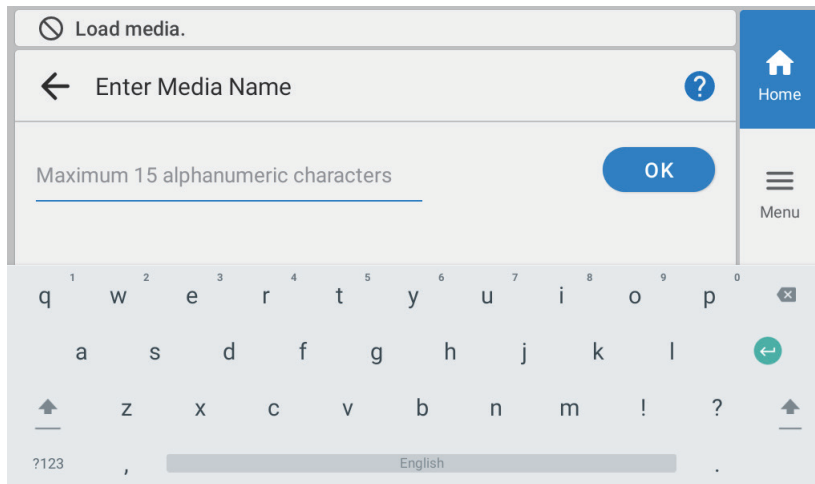

- (3) Tap [Change] on the [Printing Area Settings] screen.

The [Set the right edge of the printing area within the area specified by the pinch rollers.] screen appears.

- (4) Hold down < or > to move the center of the blade (A) approximately 2 mm (0.08 in.) to the inside (B) from the left edge of the right pinch roller.

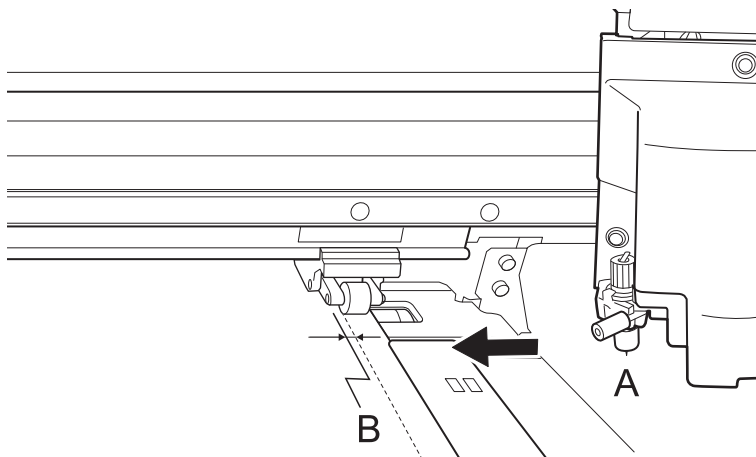

- (5) Tap [OK].

The [Set the left edge of the printing area within the area specified by the pinch rollers.] screen appears.

- (6) Hold down < or > to move the center of the blade (A) approximately 2 mm (0.08 in.) to the inside (B) from the right edge of the left pinch roller.

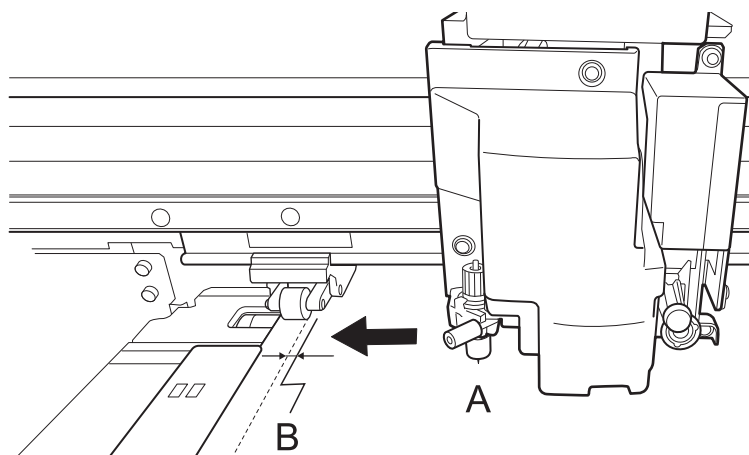

(7) Tap [OK].

The set left and right positions are applied to the [Printing Area (Width)].

(8) Tap [OK].

If the take-up unit is not used, setup is now completed.

4. Loading the Media in the Take-up Unit

Procedure

1. Follow the procedure below to load a paper tube on the media holders of the take-up unit.
Prepare a paper tube wider than the media that has been set up.

IMPORTANT

Paper tubes are consumable items.

Watch the condition of the paper tube and replace at an appropriate time so that the media can be taken up in good working order.

- (1) Release the media holders to enable their movement.

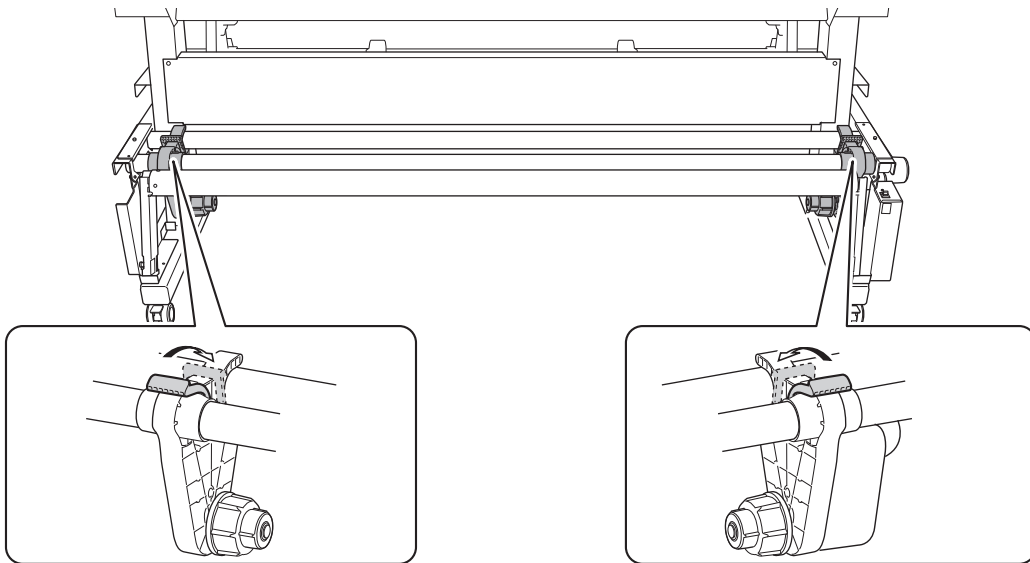

- (2) Draw the media holders to both left and right ends respectively.

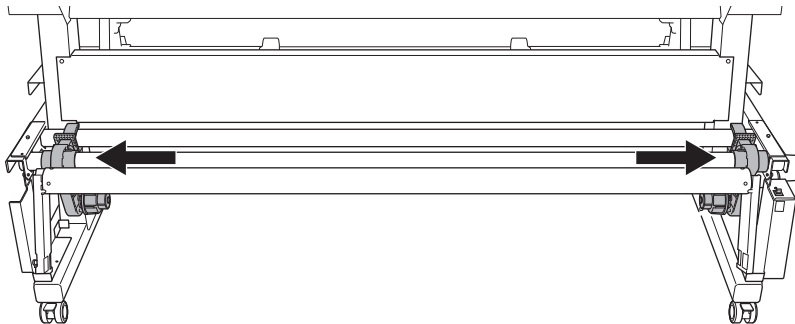

- (3) Fit the paper tube onto the right end cap.
Fit the paper tube securely right to the end of the end cap.
- (4) Push the left media holder into the paper tube.

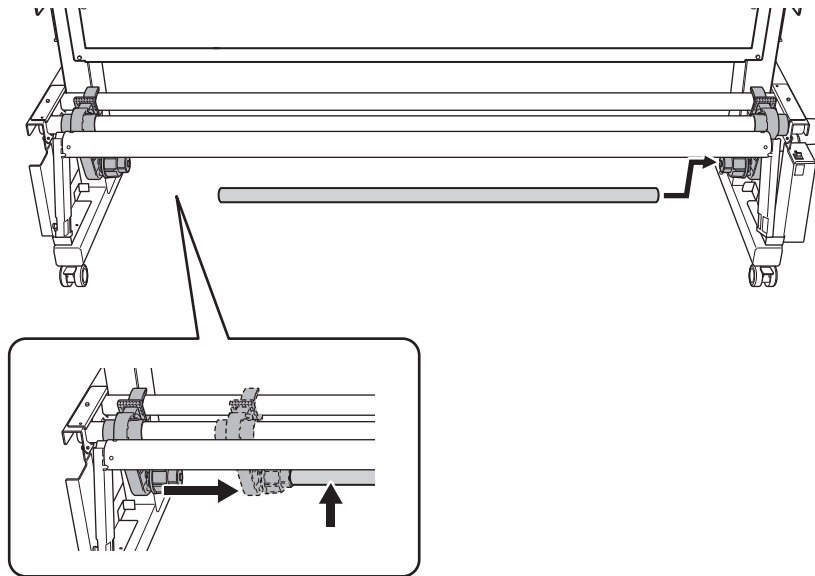

2. Tap  on the operation panel to feed out the media until the tip of the media reaches the paper tube. Media is fed out 10 mm (0.39 in.) each time you press this button. Holding down the key lets you feed out paper continuously.

MEMO

Feed out the media until it can wrap around at least 1/4 of the paper tube (or at least halfway around when rewinding during cutting).

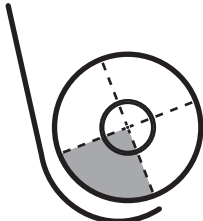
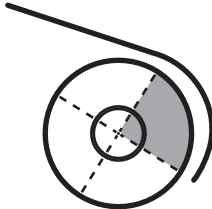
When using the FORWARD setting	When using the BACKWARD setting
	

3. Follow the procedure below to adjust the positions of the media holders.
 - (1) Move both media holders so that it is possible to see the paper tube from both edges of the media. Hold the media holders from the outside and move them.

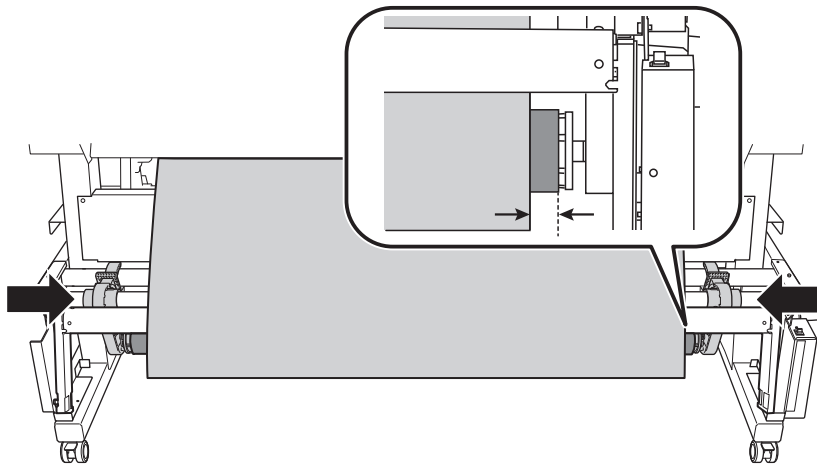

(2) Secure the left and right media holders.

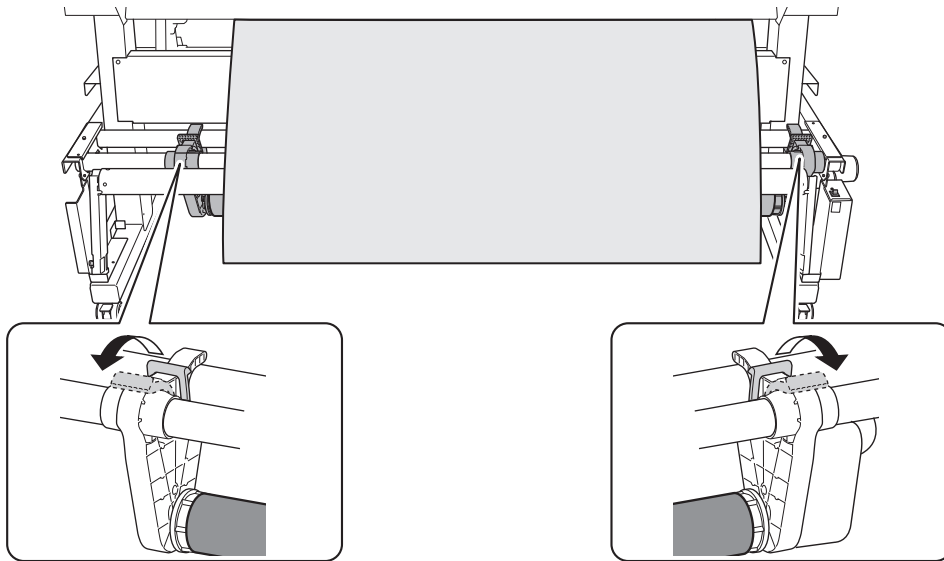

4. Follow the procedure below to secure the media on the paper tube.

Secure the media in the take-up direction set in step 3 of 1. [Installing the Media on the Media Holders\(P. 78\)](#).

- (1) While pulling the media so that it does not sag, secure the center of the media on the paper tube with adhesive tape.
 - (2) While pulling the media from the center toward the outer edges, secure the left and right edges of the media on the paper tube with adhesive tape.
- When using the FORWARD setting

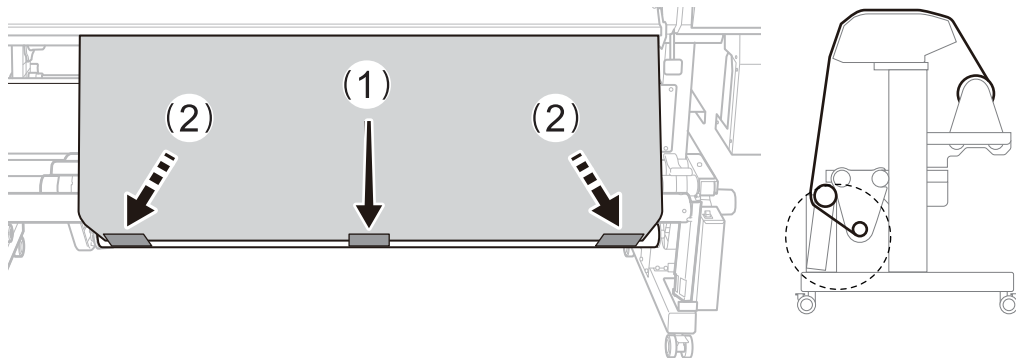

- When using the BACKWARD setting

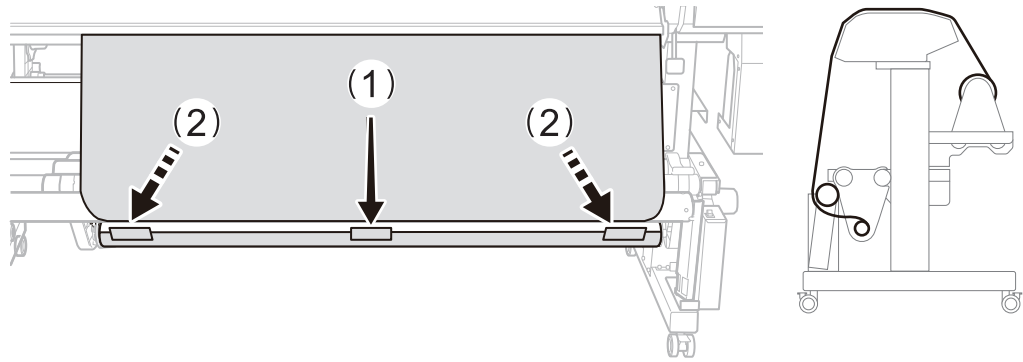

5. Tap [OK].
A small amount of the media is fed out.
6. Lower the dancer roller toward the front.

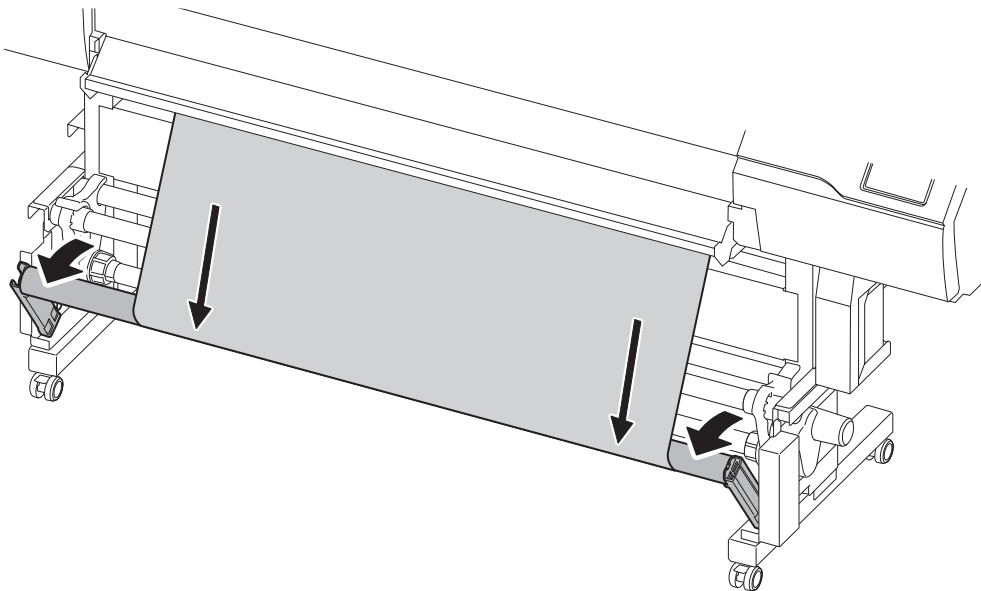

7. Tap [OK].

IMPORTANT

Remove when not using roll media.

Do not leave roll media loaded on the machine for a long period of time. Be sure to remove and store the media when not in use. Leaving the roll media loaded on the machine for a long period of time will cause the media to sag, which may deteriorate the printing quality and may also lead to motor errors.

This completes the setup.

Setup of Sheet Media

Load the sheet media on the printer. When the loading is finished, [Output possible.] is displayed as the status. This work is referred to as "Setup of Media."

1. A: Determine the positions of the media.

This section describes how to use the suction fan to prevent media skewing.

Because the suction fan does not operate, the following procedure cannot be used to load media when using transparent media or media with high reflectance whose edges cannot be detected, or when [Disable] is set for [Preferences]>[Media Edge Detection]. In these cases, refer to [1. B: Determining the Positions of Media \(If \[Media Edge Detection\]: \[Disable\]\)\(P. 109\)](#).

By default, [Skewing Correction Support at Setup] is set to [Enable].

Procedure

1. Tap the operation panel.

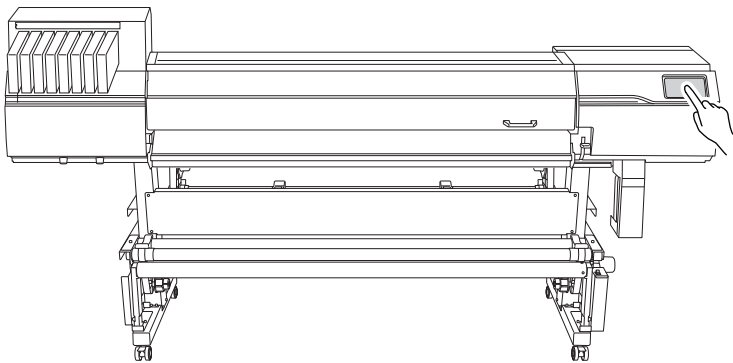

2. When instructions appear on the screen, tap the operation panel again.
The machine sub power is switched on.
3. Set the [Skewing Correction Support at Setup].
 - (1) Tap
 - (2) Tap [Preferences]>[Skewing Correction Support at Setup].
 - (3) Select [Enable] and tap [Save].
 - (4) Press to return to the home screen.
4. Open the front cover.
5. Move the media clamps to the outside of the grit rollers on the left and right edges respectively.

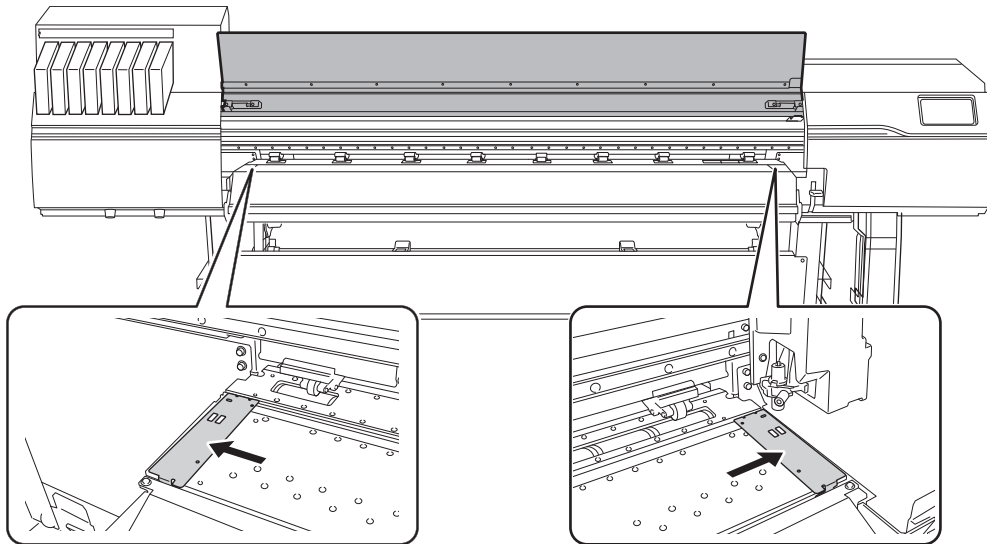

6. Move to the rear of the printer. Release the locking mechanisms of the media holders, and then draw them to the left and right ends respectively.

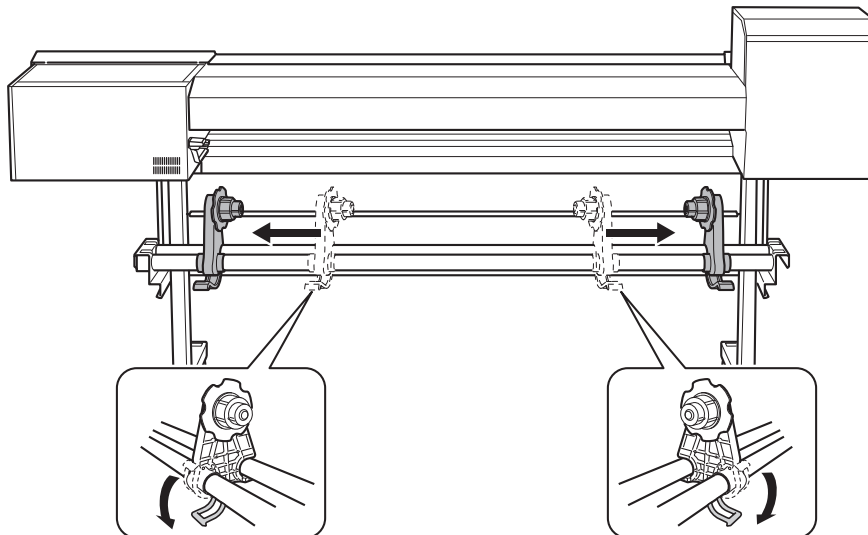

7. Determine the left and right positions of the media with the grit patterns used as the reference. Note the following points when determining the positions.
- Ensure that the left edge of the media is positioned so that it is within the range of the grit pattern of the left edge.
 - Ensure that the right edge of the media is positioned so that it is within the range of one of the grit patterns.

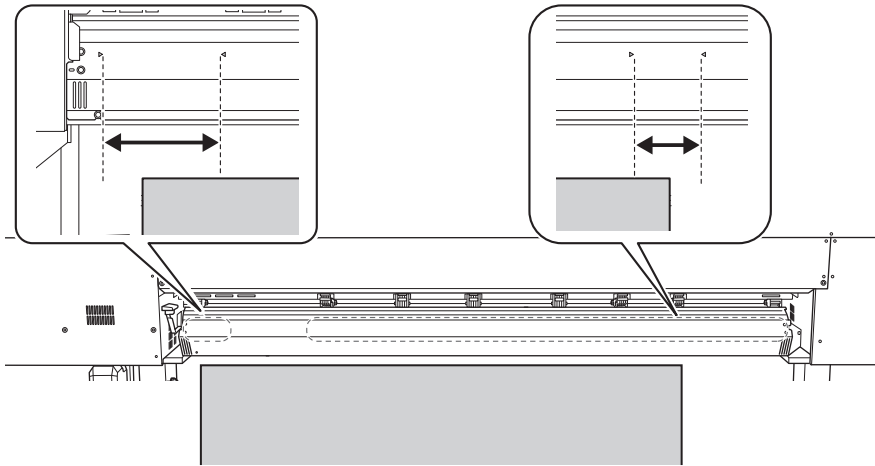

8. From the rear of the printer, pass the leading edge of the media between the pinch rollers (①) and the grit rollers (②).

You will hear a beep. Approximately 5 seconds later, you will hear two beeps, and then the suction fan will activate. While this fan is operating, the media will not move backward even if you remove your hands from it.

When loading the media from the front of the printer, feed the leading edge of the media (the side where printing will start) over the platen, and then pull the media to the front to activate the suction fan.

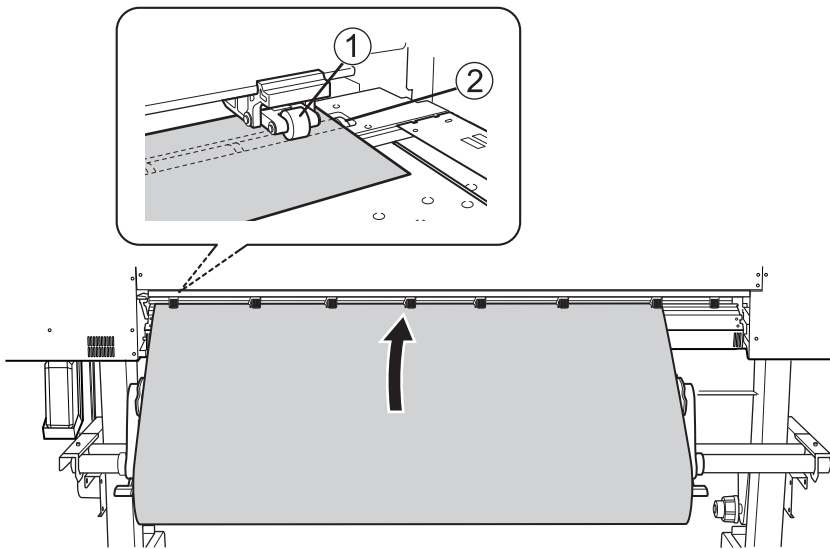

9. (Move to the front of the printer.) Make sure both edges of the media are above the grit rollers. Be sure to place the right edge of the media on the right-end grit roller.

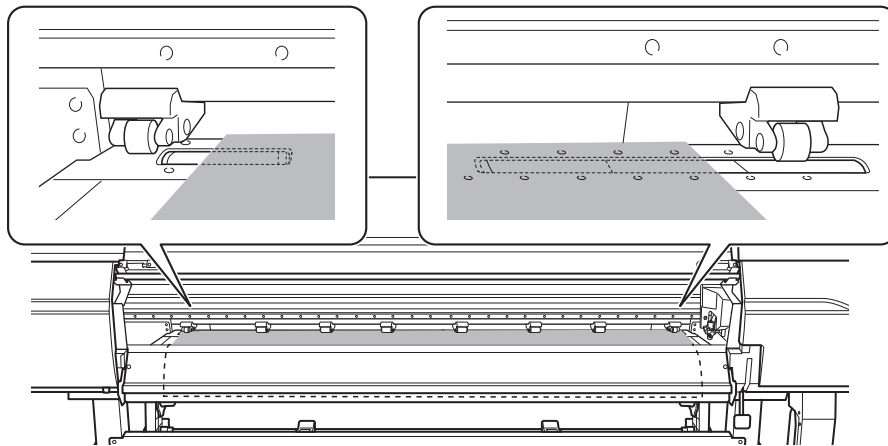

- 10.** Move the left and right pinch rollers, placing them on both edges of the media. Position them approximately 10 mm (0.39 in.) from each edge of the media.

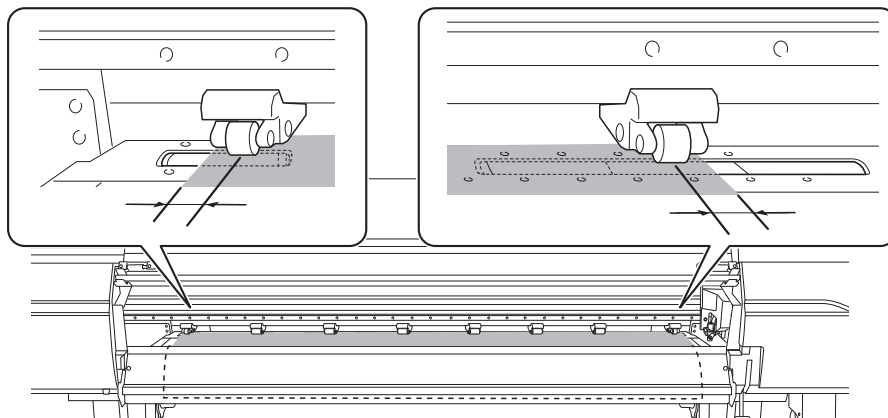

IMPORTANT

- Be sure to use the left and right pinch rollers. The force with which the media is pinched varies between the middle pinch rollers and the left and right pinch rollers. Using the middle pinch rollers to pinch the media edges will lead to unstable media feeding.
- If you want to readjust the media position before securing it in place, redo the procedure from step 7.

MEMO

To smoothly move the pinch rollers, push down close to the rail.

- 11.** Move the middle pinch rollers (B) over all the remaining grit rollers (A) covered by the media. There are grit patterns (C) wherever there are grit rollers.

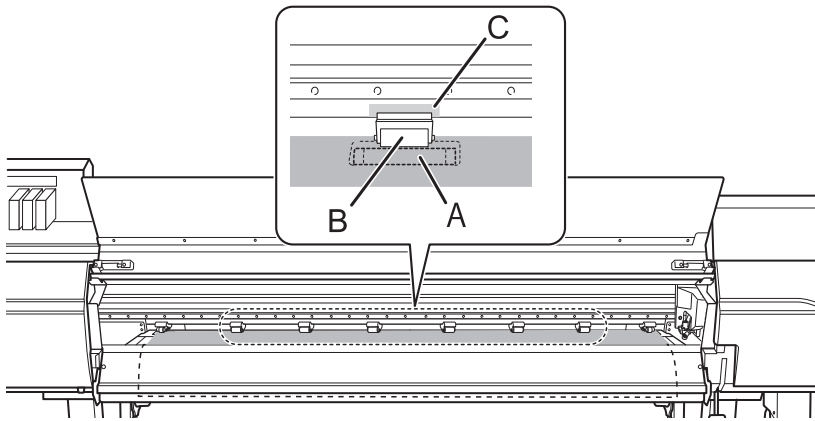

IMPORTANT

- Place the middle pinch rollers over all the grit patterns within the media width. If you have forgotten to place the middle pinch rollers, the media will be skewed during printing or will come loose, which will have an effect on the printing quality.
- The middle pinch roller will not lower onto the three grit rollers from the right end. Place the middle pinch roller on a grit roller other than these three.

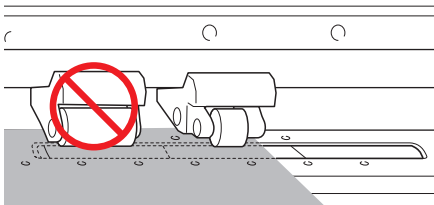

- There may be extra middle pinch rollers depending on the width of the media being used. Move the extra middle pinch rollers to positions where no grit patterns are present. Where no grit patterns are present, the middle pinch rollers will not come down.

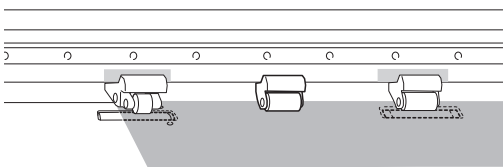

12. Lower the loading lever (front).

The media is held in place.

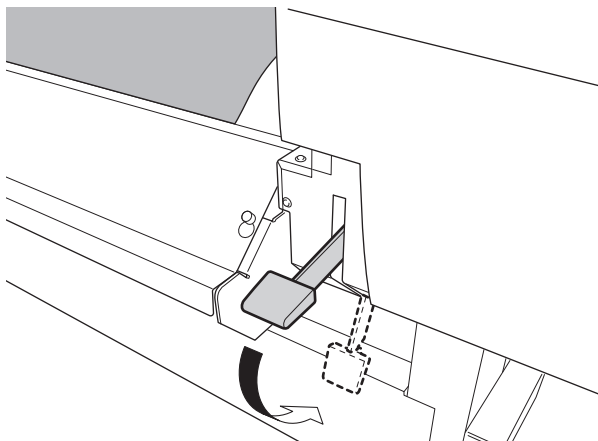

IMPORTANT

If you want to readjust the media position before securing it in place, redo the procedure from step 7.

- 13.** Line up the edges of the media with the centers of the holes of the left and right media clamps.

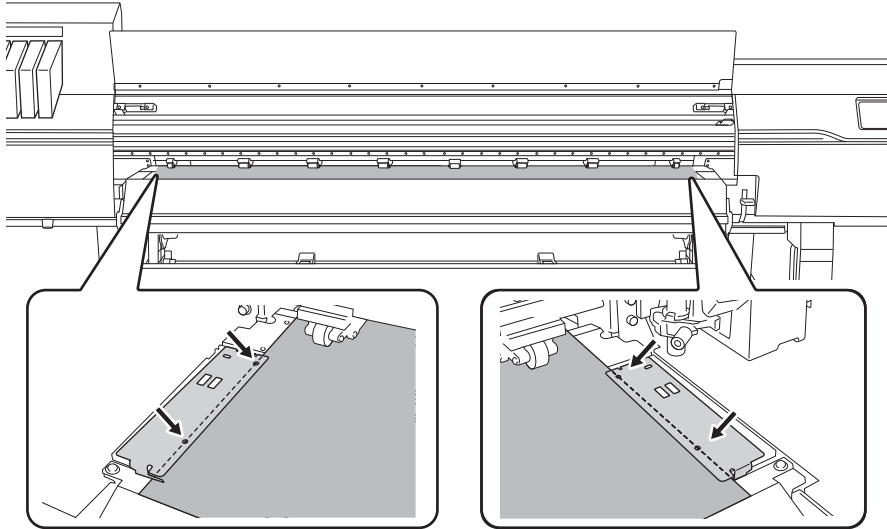

IMPORTANT

Be sure to use the media clamps when you set up media.
If you load the media clamps directly before printing after the media setup is complete, the machine may print on the media clamps.

- 14.** Close the front cover.

1. B: Determining the Positions of Media (If [Media Edge Detection]: [Disable])

Use the following procedure to determine the positions of the media when using transparent media or media with high reflectance whose edges cannot be detected, and when [Preferences]>[Media Edge Detection] is set to [Disable].

Procedure

1. Tap the operation panel.

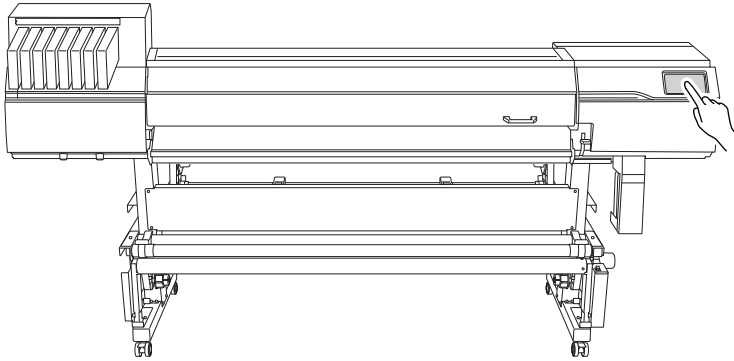

2. When instructions appear on the screen, tap the operation panel again.
The machine sub power is switched on.

3. Set the [Skewing Correction Support at Setup].

- (1) Tap
- (2) Tap [Preferences]>[Skewing Correction Support at Setup].
- (3) Select [Disable] and tap [Save].
- (4) Press to return to the home screen.

4. Open the front cover.

5. Move the media clamps to the outside of the grit rollers on the left and right edges respectively.

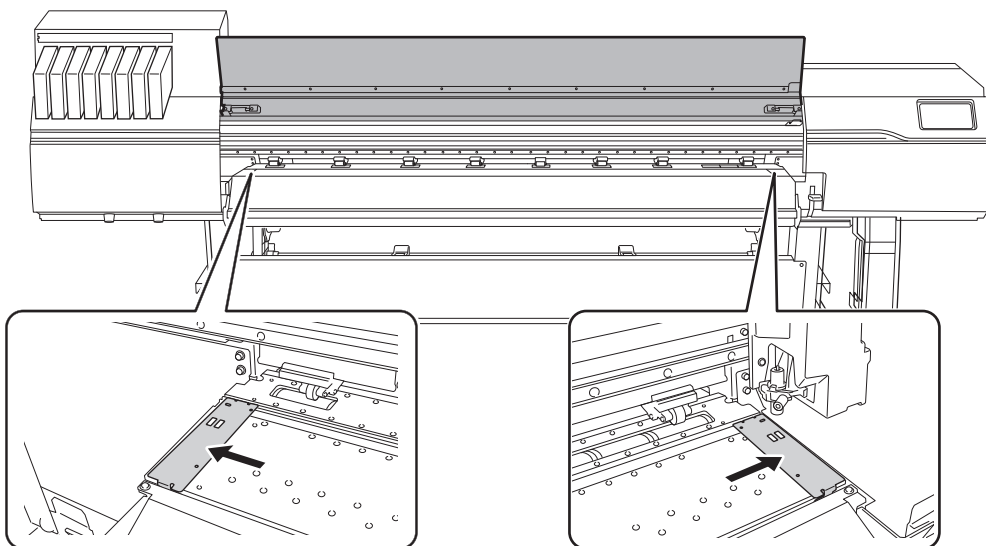

6. Move to the rear of the printer. Release the locking mechanisms of the media holders, and then draw them to the left and right ends respectively.

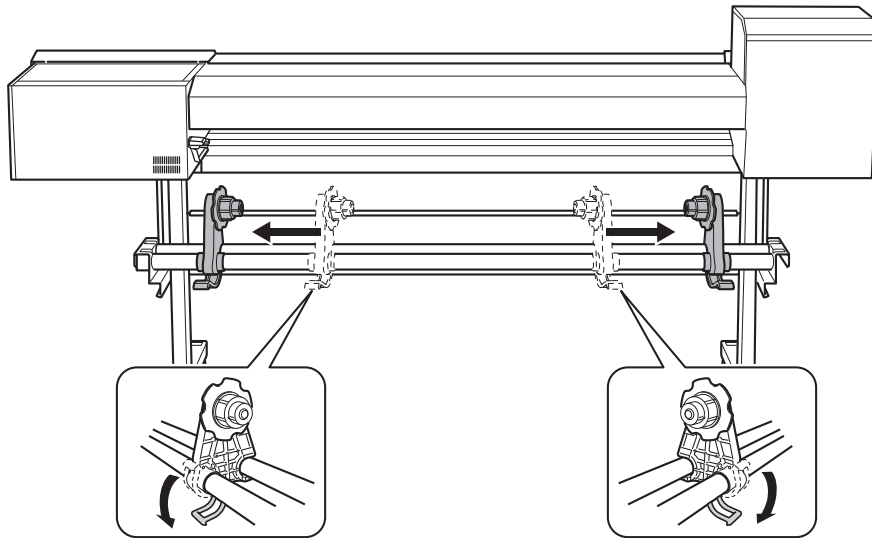

7. Determine the left and right positions of the media with the grit patterns used as the reference. Note the following points when determining the positions.

- Ensure that the left edge of the media is positioned so that it is within the range of the grit pattern of the left edge.
- Ensure that the right edge of the media is positioned so that it is within the range of one of the grit patterns.

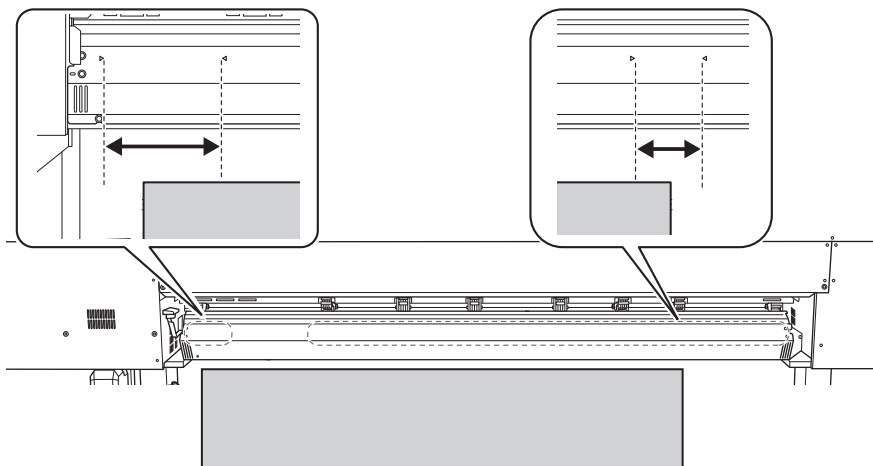

8. Pass the leading edge of the media between the pinch rollers (①) and the grit rollers (②).

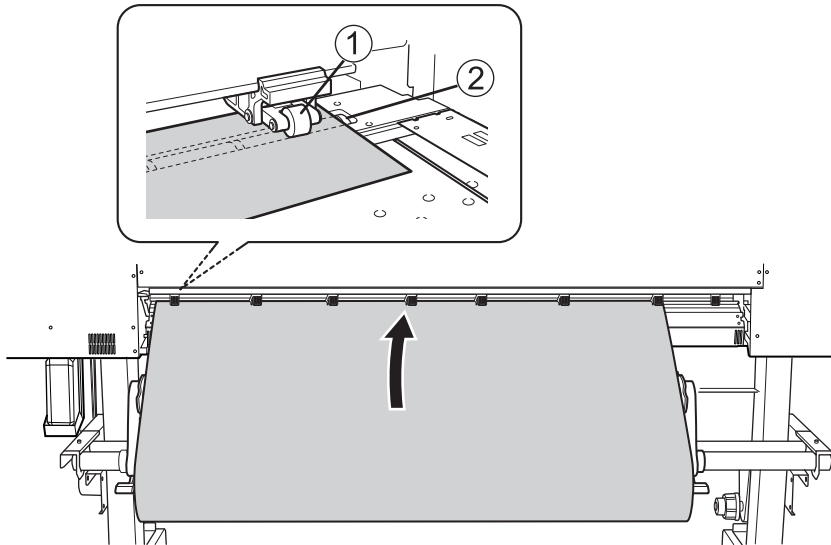

- 9. Lower the loading lever (rear).**
The media is held in place.

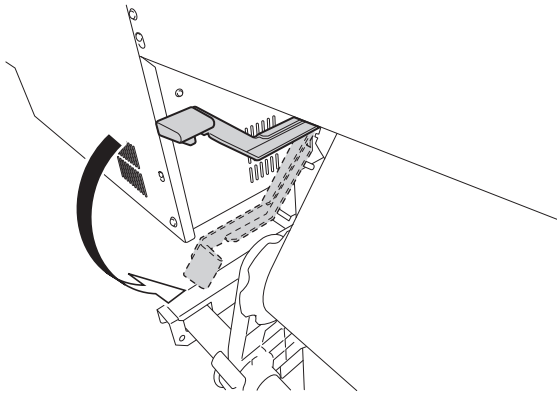

- 10. (Move to the front of the printer.) Gently hold down the media and raise the loading lever (front).**

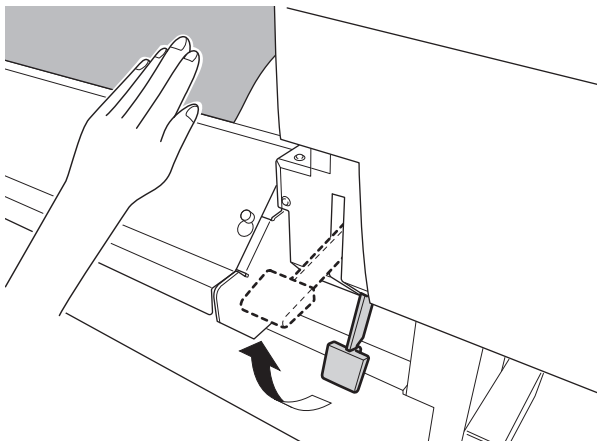

- 11. Make sure both edges of the media are above the grit rollers.**
Be sure to place the right edge of the media on the right-end grit roller.

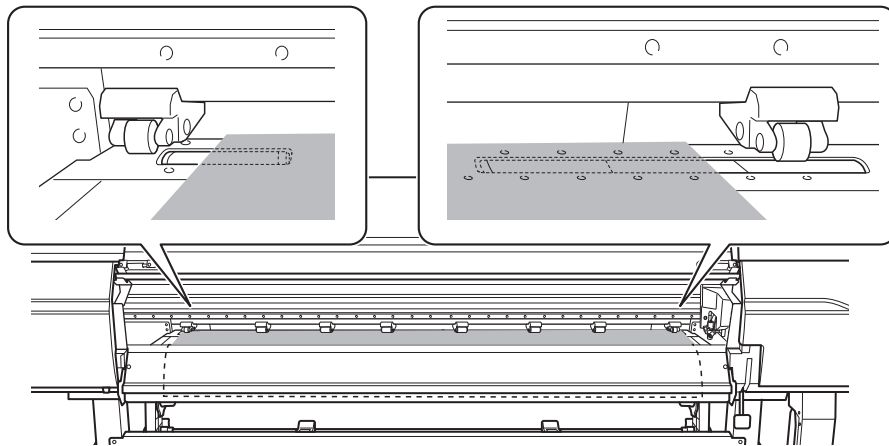

- 12.** Move the left and right pinch rollers, placing them on both edges of the media. Position them approximately 10 mm (0.39 in.) from each edge of the media.

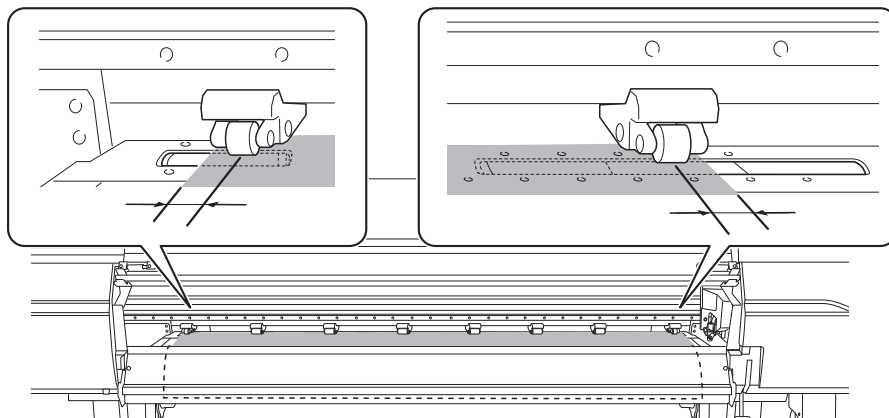

IMPORTANT

Be sure to use the left and right pinch rollers. The force with which the media is pinched varies between the middle pinch rollers and the left and right pinch rollers. Using the middle pinch rollers to pinch the media edges will lead to unstable media feeding.

MEMO

To smoothly move the pinch rollers, push down close to the rail.

- 13.** Move the middle pinch rollers (B) over all the remaining grit rollers (A) covered by the media. There are grit patterns (C) wherever there are grit rollers.

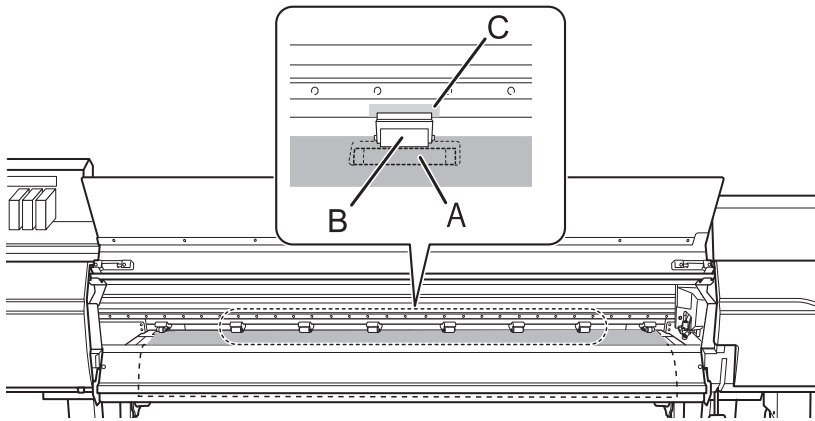

IMPORTANT

- Place the middle pinch rollers over all the grit patterns within the media width. If you have forgotten to place the middle pinch rollers, the media will be skewed during printing or will come loose, which will have an effect on the printing quality.
- The middle pinch roller will not lower onto the three grit rollers from the right end. Place the middle pinch roller on a grit roller other than these three.

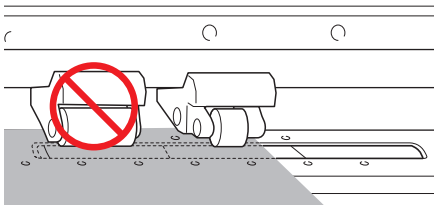

- There may be extra middle pinch rollers depending on the width of the media being used. Move the extra middle pinch rollers to positions where no grit patterns are present. Where no grit patterns are present, the middle pinch rollers will not come down.

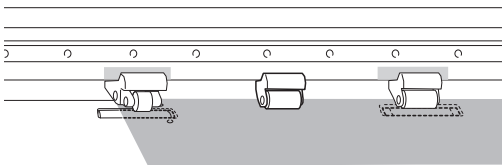

14. Lower the loading lever (front).

The media is held in place.

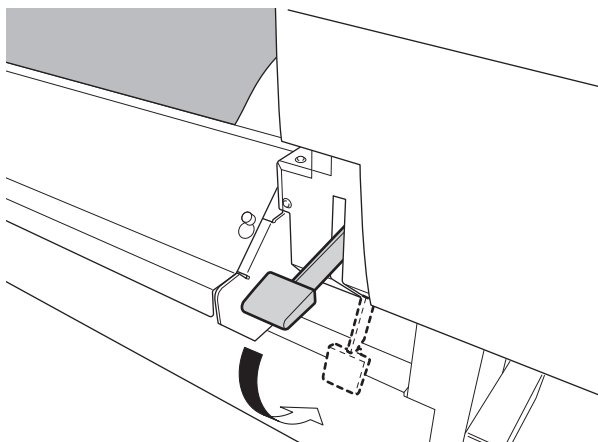

IMPORTANT

If you want to readjust the media position before securing it in place, redo the procedure from step 11.

15. Line up the edges of the media with the centers of the holes of the left and right media clamps.

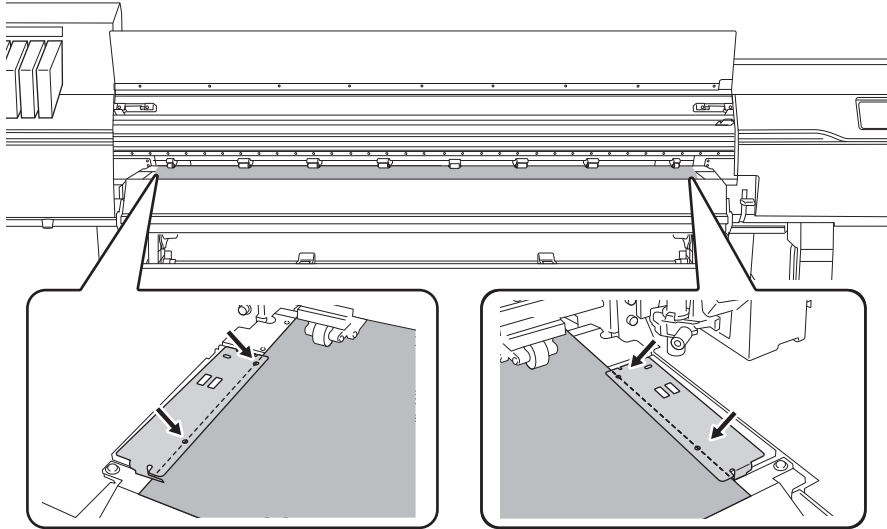

IMPORTANT

Be sure to use the media clamps when you set up media.

If you load the media clamps directly before printing after the media setup is complete, the machine may print on the media clamps.

16. Close the front cover.

2. Select the media.

Procedure

1. Tap  [Setup].

The registered media is displayed in a list.

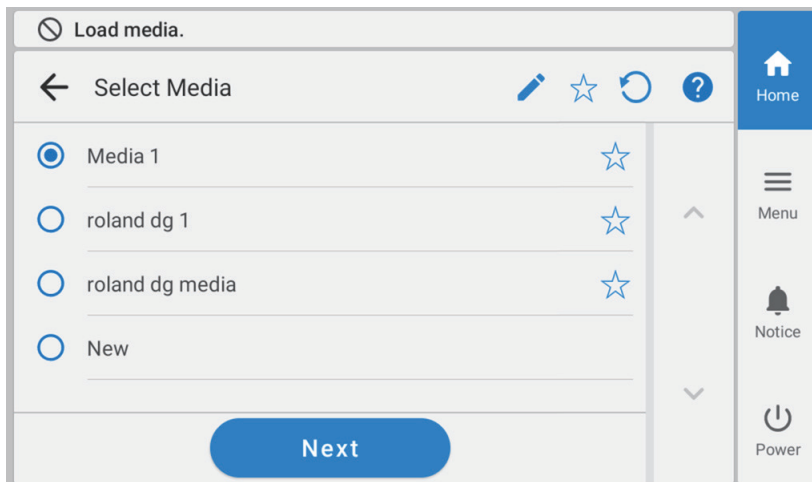

2. Select the media name to use.



MEMO

You can search for media in the media list by keyword and register media as favorites. The media list can also be set to show only media registered as favorites. Keyword searching and favorites registration can be used at the same time.

- **Searching for keywords in the media list**

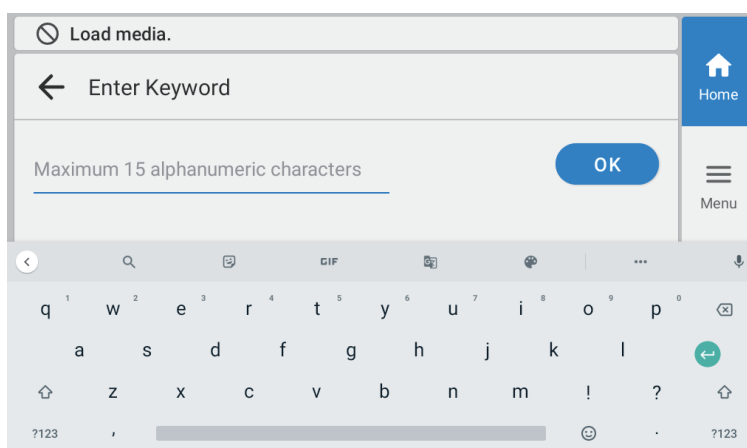
1. Tap .
2. Enter the media to search for.
Searching for partial matches instead of exact matches is also possible.



3. Tap [OK].
Media filtered according to the keywords will be displayed.
 4. Select the media to use from the search results.
- **Registering media to favorites and showing only media registered as favorites**
Tap  for the media to register it to favorites.
The icon for the favorited media will be displayed as .

To show only media registered as favorites, tap the icon indicated below.

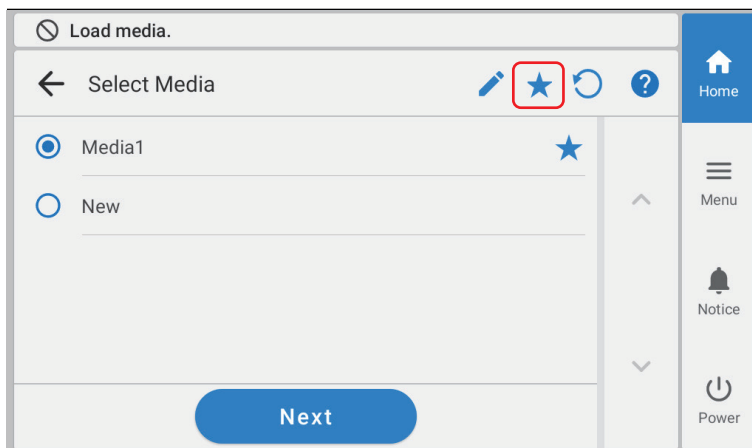

To reset the keyword search or favorites registration, tap .

When using both the keyword search and favorites registration, each function can also be reset individually.

To reset the keyword search, tap  to delete the keyword.

To reset the favorites registration, tap  for the media you want to reset.

3. Tap [Next].

4. The [Setup Method] screen appears. Select whether to use the take-up unit.

5. Tap [Start Setup].

The cutting carriage moves and detects the width of the media and the positions of the media clamps. This operation is called initialization.

6. When [The media could not be detected automatically. Manually set the printing] screen appears, use the following procedure to configure the settings.

MEMO

- This message may appear when media with high reflectance is set up.
- If automatic media detection is not possible and the printing area is set manually when new media is registered, the screen automatically changes to the [Printing Area Settings] screen in Step (3).

(1) Tap [OK].

(2) Enter a new media name and tap [OK].

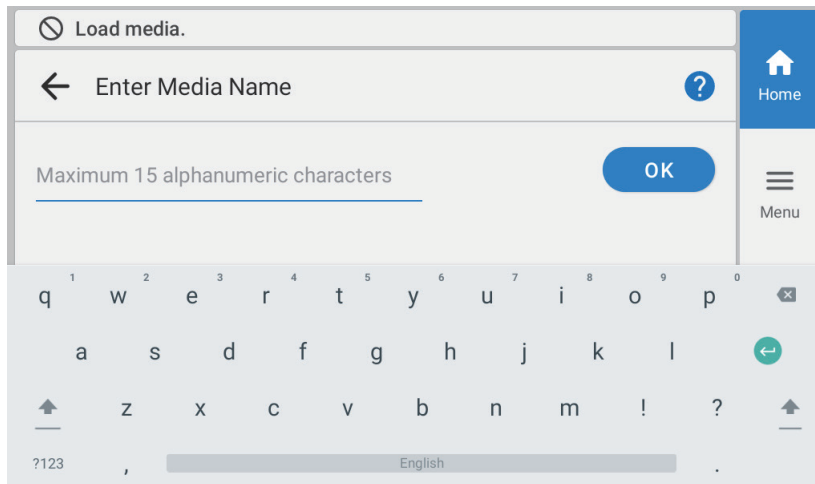

- (3) Tap [Change] on the [Printing Area Settings] screen.

The [Set the right edge of the printing area within the area specified by the pinch rollers.] screen appears.

- (4) Hold down < or > to move the center of the blade (A) approximately 2 mm (0.08 in.) to the inside (B) from the left edge of the right pinch roller.

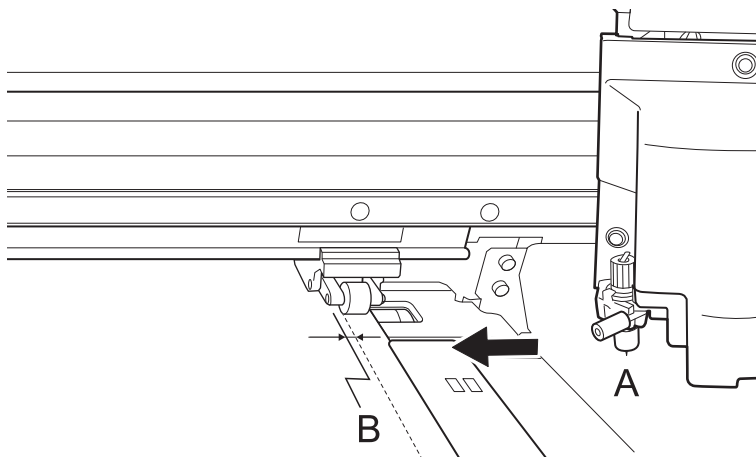

- (5) Tap [OK].

The [Set the left edge of the printing area within the area specified by the pinch rollers.] screen appears.

- (6) Hold down < or > to move the center of the blade (A) approximately 2 mm (0.08 in.) to the inside (B) from the right edge of the left pinch roller.

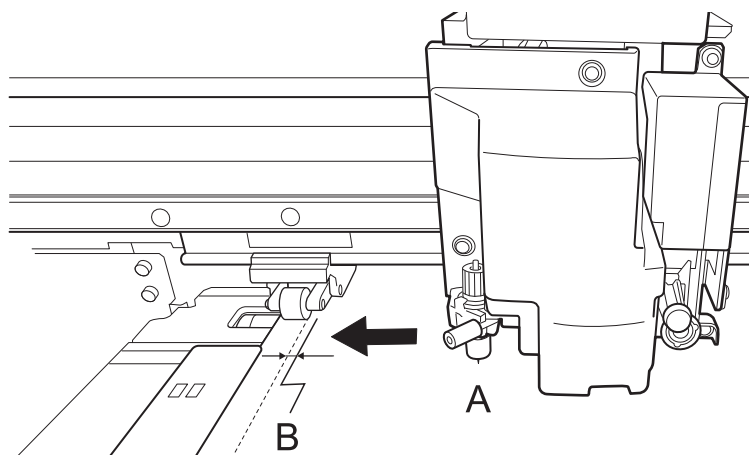

(7) Tap [OK].

The set left and right positions are applied to the [Printing Area (Width)].

(8) Tap [OK].

Checking before Output

LAN (Local Area Network) Settings

Check that you can perform communication through the LAN (Local Area Network).

The LAN is enabled if the status LED (②) on the LAN connector located on the side of the printer is lit in green.

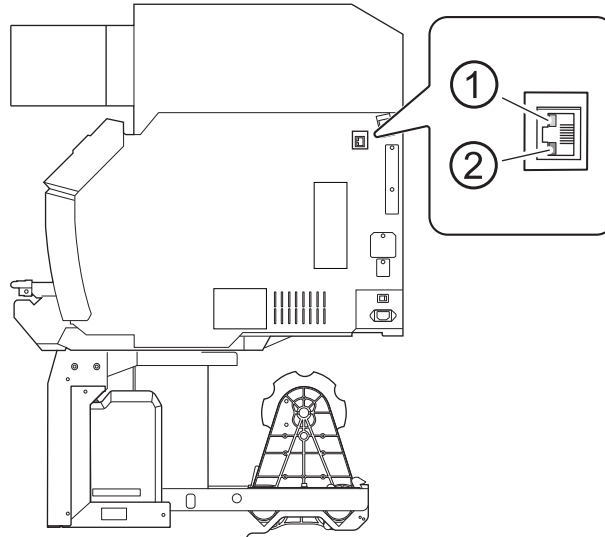

①	Activity LED	This lights up or flashes orange while data is being received from the network.
②	Status LED	This indicates the status of the communication function. When it lights in green, communication is possible.

Pausing and Canceling Output

You can pause and cancel output before it finishes.

Pausing and Resuming Output

IMPORTANT

We do not recommend resuming printing because horizontal bands are produced at the place where printing was paused.

MEMO

Some menu items can be operated during output, but return to the home screen before pausing output.

Procedure

1. During output, tap [Pause].
This pauses the printing operation.
2. Tap [Resume].

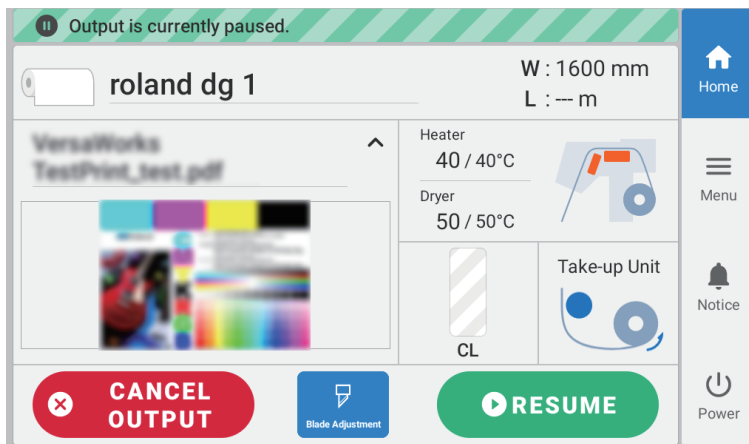

The printing operation resumes.

Canceling Output

Procedure

1. During output, tap [Pause].
This pauses the printing operation.
2. Tap [Cancel Output] when the following screen appears.

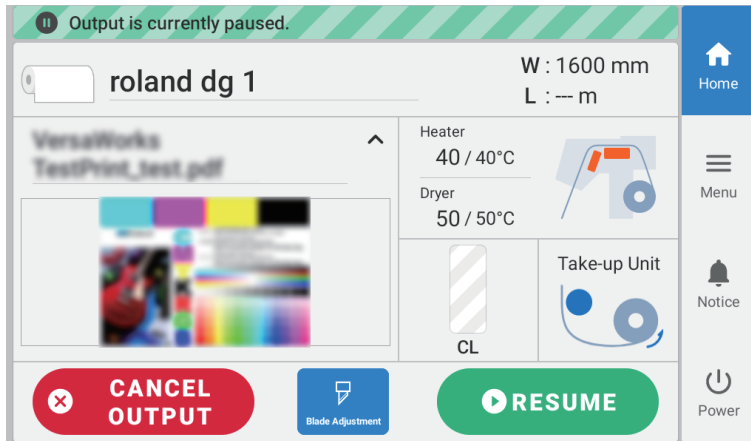

Output is canceled.

3. Stop sending the output data from the computer.

MEMO

The cleaning and printing test below can be canceled. Tap  during cleaning or a printing test, then tap [Cancel] on the home screen.

- [Normal Cleaning]
- [Medium Cleaning]
- [Powerful Cleaning]
- [Normal Cleaning] after [Manual Cleaning]
- Printing test after cleaning

Separating the Media

After printing, use [Sheet Cutting] or [Perforated Sheet Cutting] to separate the media.



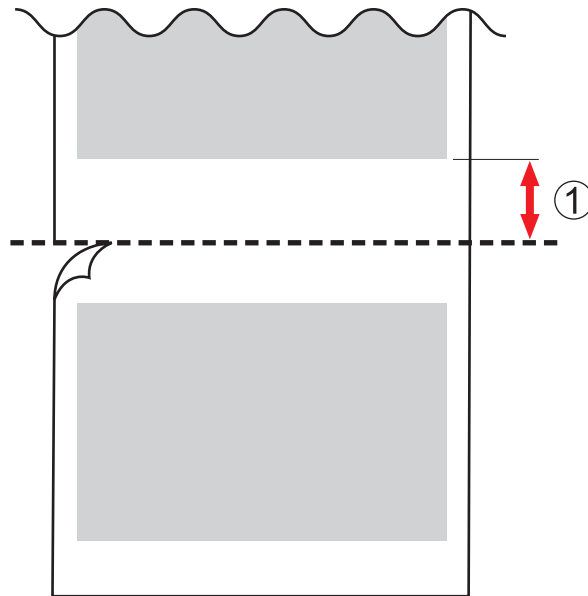

When performing [Sheet Cutting] or [Perforated Sheet Cutting], set the amount of media to feed to the next printing start position ① with [Margin After Sheet Cutting]. Under the initial settings, the next printing starts 75 mm (2.95 in.) from the front edge of the media after media separation. This function makes it possible to set the margin to the printing start location between 35 and 75 mm (1.38 and 2.95 in.).



IMPORTANT

Reducing the margin may result in the front of the media becoming loose and coming into contact with and possibly damaging the print heads. Be cautious when changing the margin.

Procedure

1. Close the front cover.
2. If necessary, use the following procedure to set the separation position.
 - (1) Tap .
 - (2) Tap  [Move].
 - (3) Tap  or  to set the media to the separation position.

The media is separated at the position in the following figure. Use the media clamp holes as a guideline for this position.

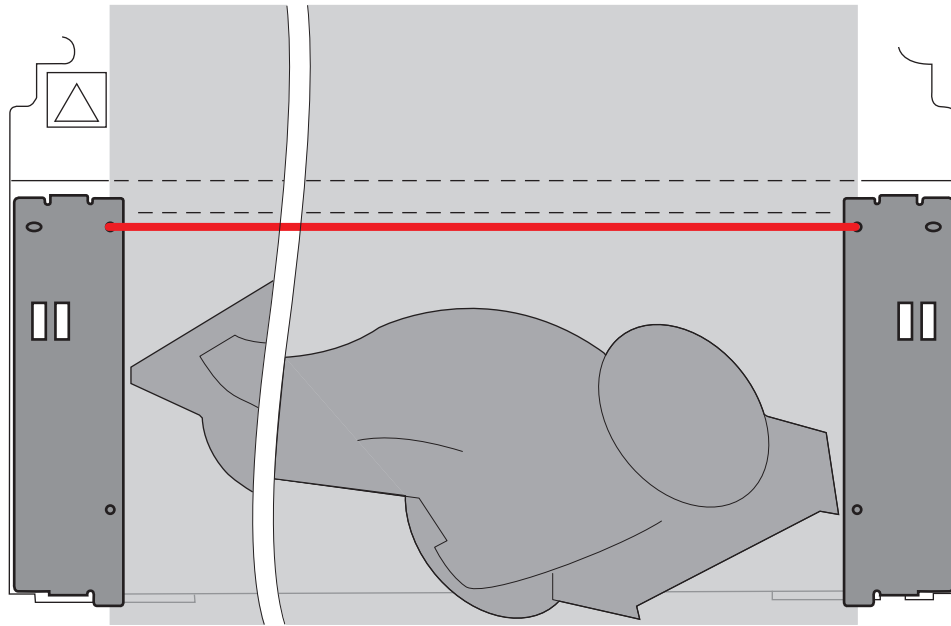

- (4) Tap [Set Base Point Here].

The separation position is set, and you are returned to the home screen.

MEMO

The display of the icon on the home screen changes to indicate that the base point position has been set.





Base

W : 1600 mm

L : --- m

3. Tap  [Sheet Cutting] on the operation panel.

4. Set the margin after media separation as necessary.

- (1) Tap [Margin After Sheet Cutting].
- (2) Tap  or  to set the margin.
- (3) Tap [Save].
- (4) Tap .

The screen returns to the sheet cutting screen.

5. Select the sheet cutting method.

[Sheet Cutting]	This separates the media. Media setup will be canceled.
[Perforated Sheet Cutting]	The media is perforated without being separated. Media setup will not be canceled.

MEMO

If the media is separated even after you select [Perforated Sheet Cutting], use [Preferences]>[Perforated Sheet Cutting] to change to the [Increase Uncut Locations] setting. If the media is heavy or has a large amount that is slack, it can be retained without being separated.

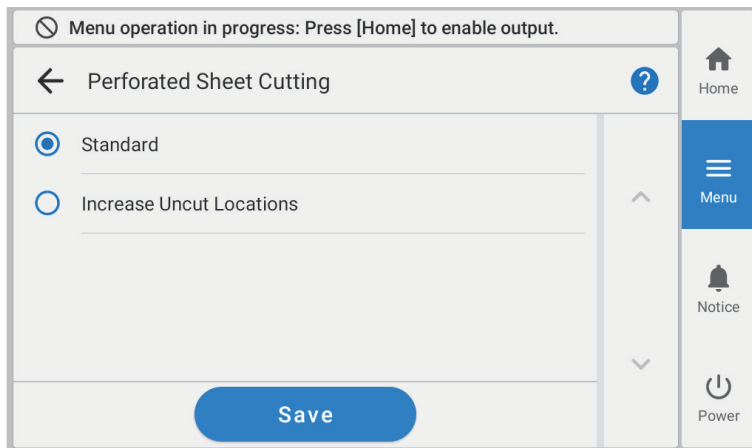

6. Tap [Execute].

The media is separated. If [Perforated Sheet Cutting] was selected in Step 5, the media is perforated.

- Some RIP software can be set to automatically separate the media after output has finished. For information on how to configure the settings, refer to the manual for the RIP software you are using.
- When using a take-up unit, take-up may be interrupted by media separation, so we recommend you turn off the automatic separation function or insert perforated sheet cutting with VersaWorks to ensure the media is not separated.

IMPORTANT

Separation Operations

- If the distance from the end of the media to the separation location is short, separation may not be performed smoothly.

When Using a Take-up Unit

- Do not operate the manual switch on the take-up unit leaving the loading lever lowered. Tension is applied to the media by the take-up unit, so avoid operations that pull the media with excessive force.

Give Attention to the Media Composition

- For some types of media, separation is not possible.
- Some types of media may remain on the platen after separation. If the media remains on the platen, remove it by hand.

Removing Media from the Take-up Unit

When output is complete, separate the media, take up the media manually, and then remove the media.

⚠ WARNING

Handling roll media is an operation that must be performed by 2 persons or more, and care must be taken to prevent falls.

Attempting to lift heavy media in a manner that taxes your strength may cause physical injury. Also, if dropped, such items may cause injury.

Procedure

1. Lower the dancer roller toward the rear.

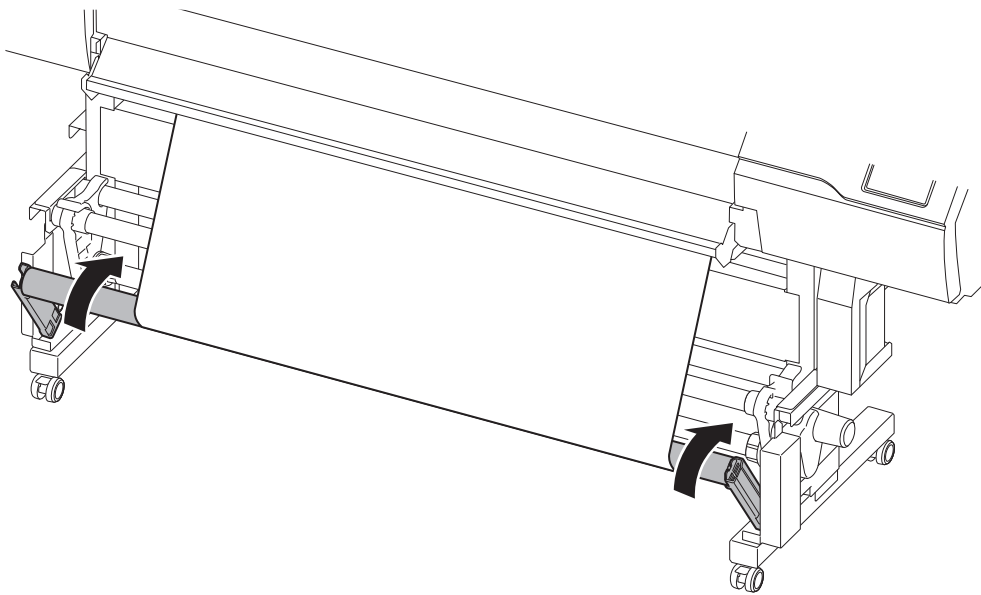

2. Close the front cover.
3. With the media held down, tap  [Sheet Cutting] on the operation panel.
P. 122 Separating the Media

IMPORTANT

Give Attention to the Media Composition

- For some types of media, separation is not possible.
- Some types of media may remain on the platen after separation. If the media remains on the platen, remove it by hand.

4. Use the MANUAL switch to take-up the media.

Separating the Media

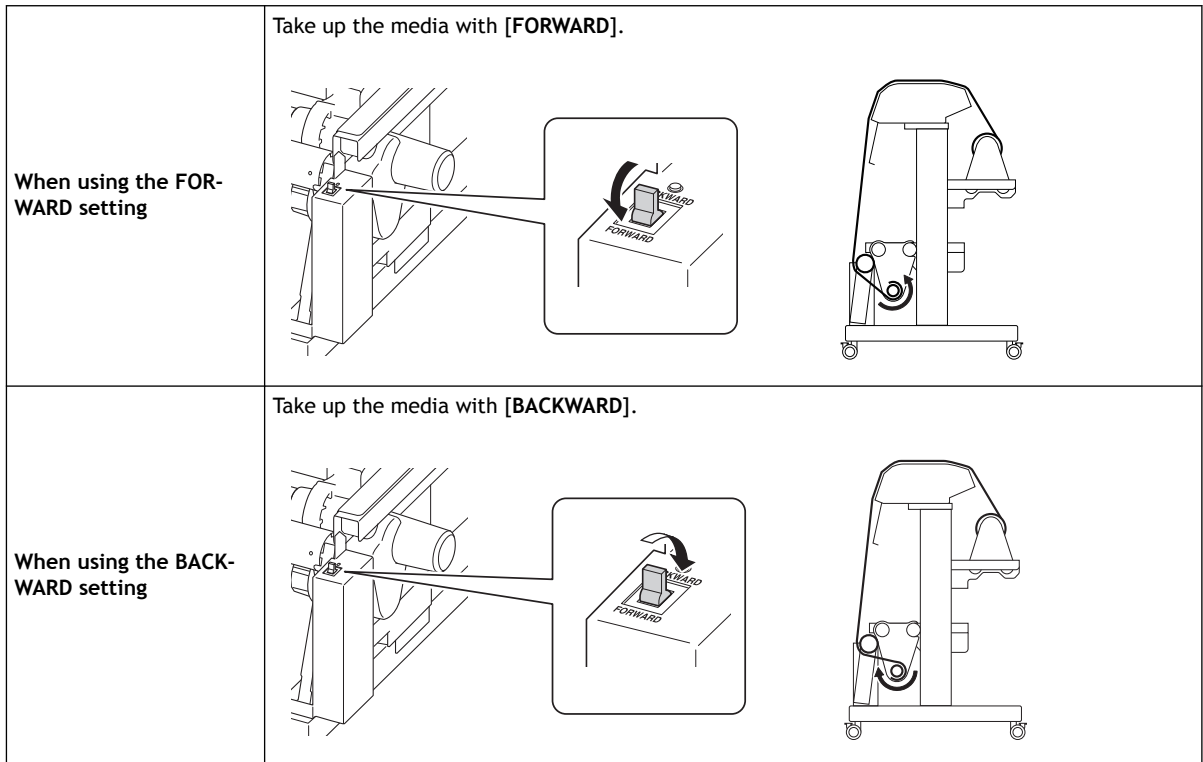

5. While supporting the media from below, loosen the securing lever on the left media holder.

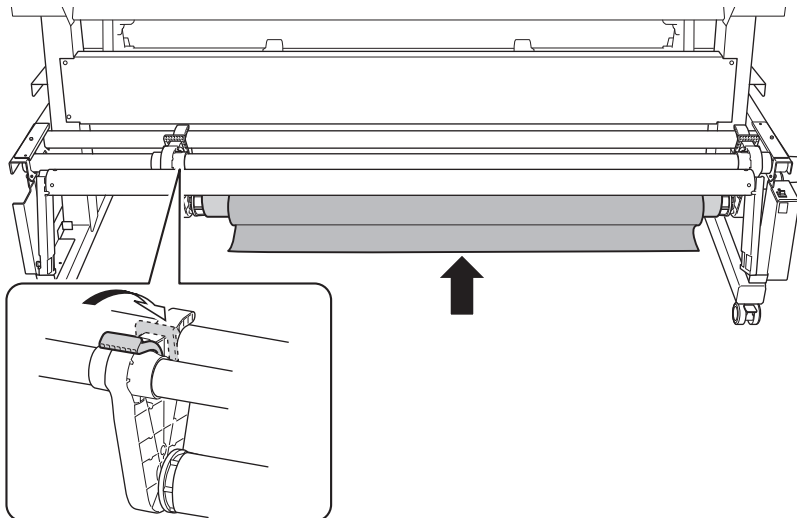

6. With the media supported, pull the paper tube and media from the end cap.

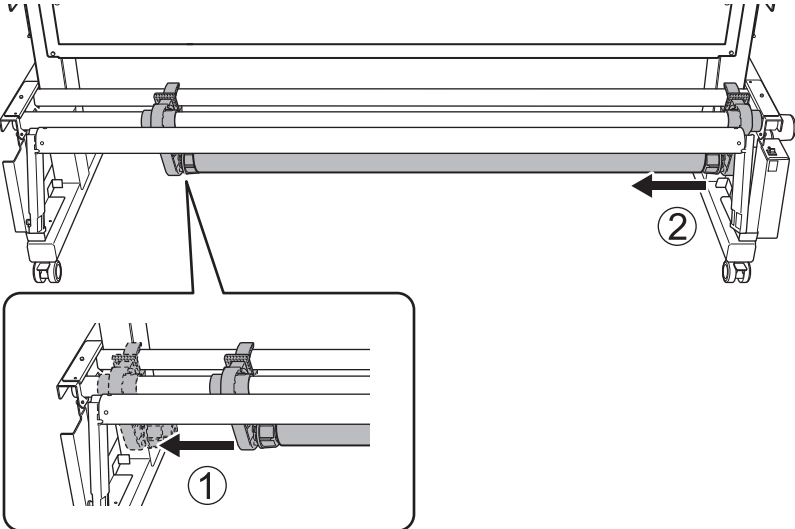

Replacing Ink Cartridges

Out-of-ink Warnings

If Using 4 Colors (CMYK)

- If two ink cartridges with the same color run out of ink: Printing pauses and a warning beep sounds. Refer to the screen display on the operation panel, pull out the empty cartridges, and insert new ones. Printing resumes.
- If one cartridge runs out of ink but there is still another cartridge with the same color: The operation panel screen continues displaying **[Printing output in progress.]**, and printing continues. Refer to the screen display on the operation panel and pull out the empty cartridge.

If Using 7 Colors (CMYKWhWhOrRe) or 8 Colors (CMYKLkGrOrRe, CMYKLcLmOrRe)

- When an ink pouch runs out, printing pauses and a warning beep sounds. Refer to the screen display on the operation panel, pull out the empty cartridges, and insert new ones. Printing resumes.

IMPORTANT

- See [Determining What Happens When Ink Runs Out\(P. 276\)](#) if you do not want printing to be paused.
- **[Ink Empty Mode]** is set to **[Stop]** by default. When changed to **[Continue]**, printing will not be paused.
- If ink runs out during cleaning, cleaning is canceled.
- Never reuse an ink cartridge for which the machine shows a sign indicating no ink. Occasionally the machine will show a sign indicating no ink even if there is a small amount of ink remaining in the ink cartridge. Nevertheless, do not reuse the ink cartridge. Such an ink cartridge is in a state where drawing ink from it is impossible. Using it in such a state may force air into the ink path and cause printer malfunctions.

Operation panel screen display

[Ink Cartridge Error] is displayed, and **[Empty]** is displayed for ink that has run out.

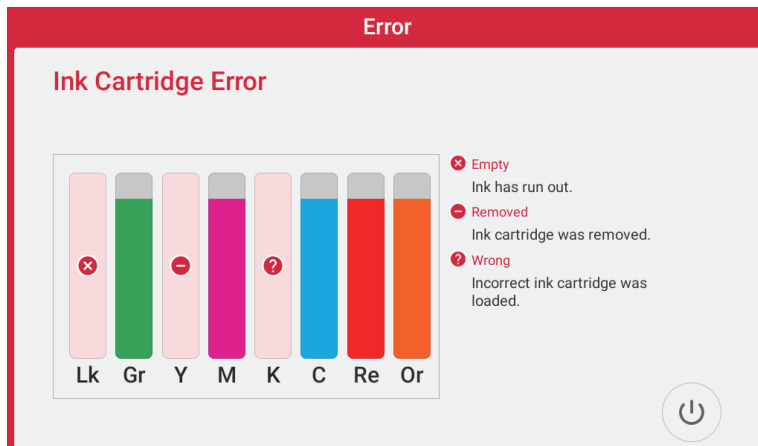

Preventing Sedimentation in Inks

Shake the ink cartridge 50 times (about 20 seconds), and then reinsert the cartridge. The precipitation of the ingredients in the ink disables printing in normal color. So that the ink mixes well, shake the ink cartridge horizontally with a stroke length of around 5 cm (1.97 in.) from each end of the ink cartridge.

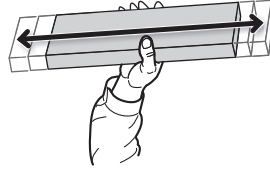

Shake the ink cartridges:

- White ink: Each day (before starting the day's operations).
- Ink other than white ink: When replaced with a new cartridge or when uneven color issues occur

MEMO

To prevent ink precipitation, you can make the machine periodically display a message prompting you to mix the ink.
[P. 275 Showing/Hiding Notifications](#)

IMPORTANT

- **The ingredients in white ink tend to settle.**
Allowing the ink to stand without shaking it can cause the settled material to harden, resulting in malfunction or other problems.
- **Before shaking the ink cartridge, wipe off any ink from around its mouth.**
If you do not wipe off the ink, it may splatter when you shake the ink cartridge.
- **When you have finished mixing the ink, reattach the ink cartridge immediately.**
Taking time to reattach the ink cartridge will adversely affect the ink path.

Cleaning Liquid Pouch Replacement

Out-of-cleaning-liquid Warnings

If the cleaning liquid runs out, [Replace the cleaning liquid pouch.] appears on the screen. Tap [OK] to close this message.

You can also check the message by tapping .

Cleaning Liquid Pouch Replacement

WARNING

Never store ink, cleaning liquid, or discharged fluid in any of the following locations.

- Any location exposed to open flame
- Any location where high temperature may occur
- Near bleach or any other such oxidizing agent or explosive material
- Any location within the reach of children

Fire may be a danger. Accidental ingestion by children may pose a health hazard.

IMPORTANT

Precautions regarding cleaning liquid pouch replacement

- Never insert or remove the cleaning cartridge with undue force. Cleaning liquid may leak.
- If the cover of the cleaning cartridge does not lock securely, this cartridge needs to be replaced.

For information about purchasing cleaning cartridges, contact your authorized dealer or visit our website (<https://www.rolanddg.co.jp/>).

Procedure

1. Pull out the cleaning cartridge from the machine.

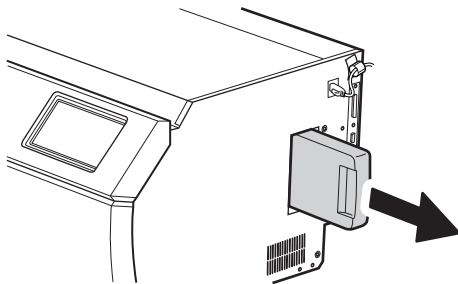

2. Remove the cover of the cleaning cartridge.
 - a. Keep the side with the arrow mark face up.
 - b. Remove the cover by sliding it in the direction indicated by the arrow.

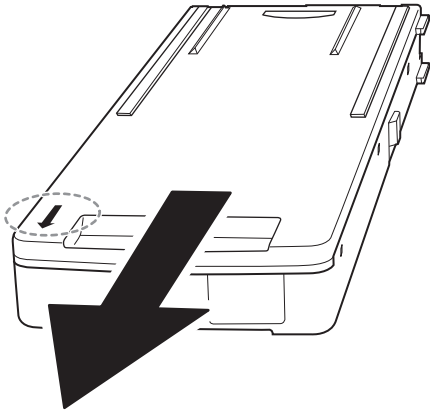

3. Remove the used cleaning liquid pouch from the cartridge case.

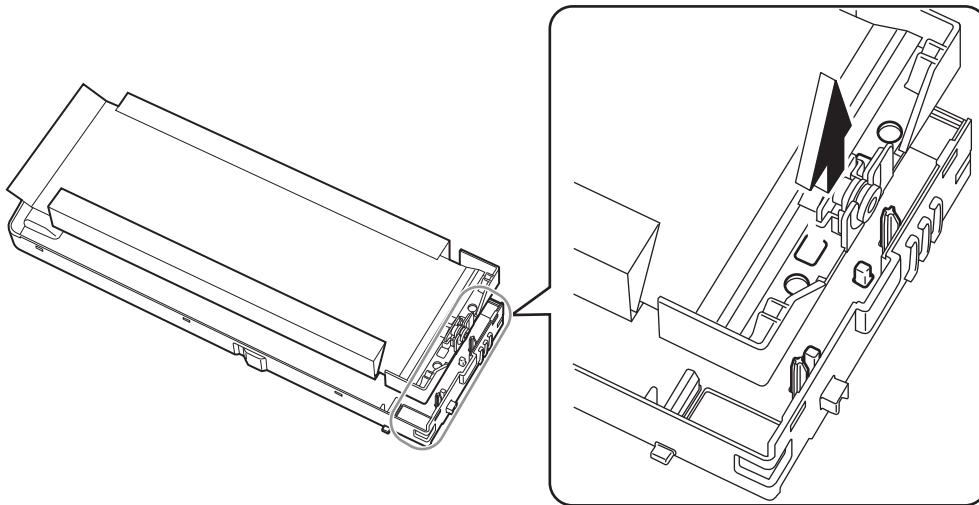

4. Load a new cleaning liquid pouch in the cartridge case.

MEMO

Pass the protrusions on the cartridge case through the holes on the cleaning liquid pouch to load it in the correct position.

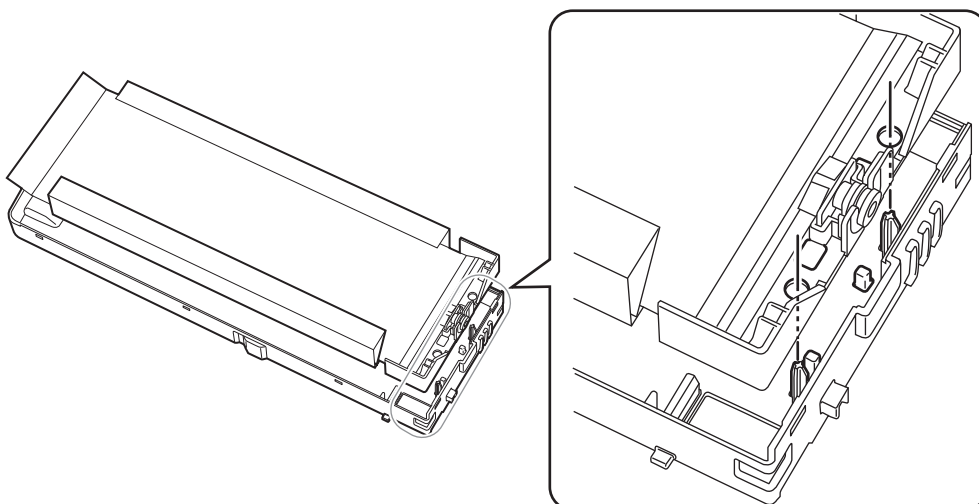

5. Attach the cover to the cartridge case.

- a. Insert the protrusions (A) at the back of the cover into the holes in the cartridge case.

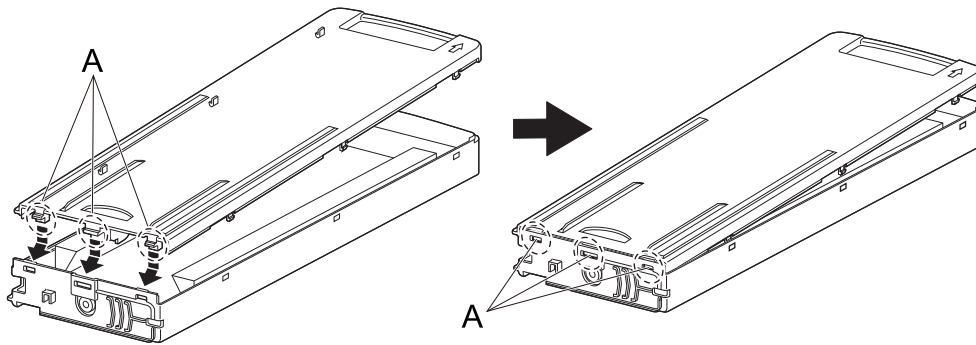

- b. Push the cover to fit its hooks into the holes in the cartridge case.
There are hooks in six locations. Check that all the hooks are seated in the holes and that the cover does not come loose from the cartridge case.

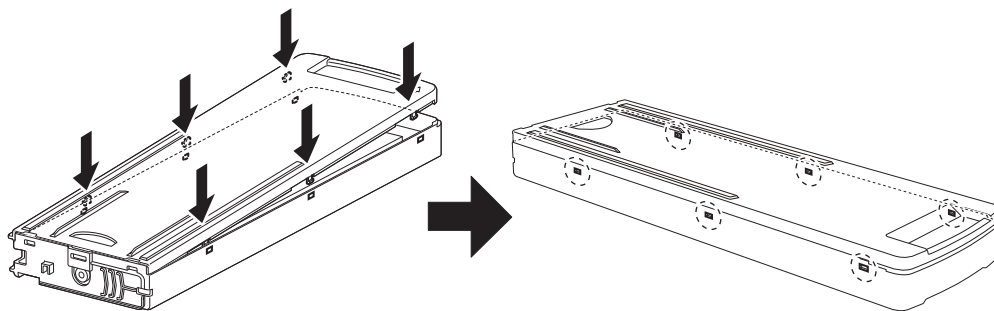

6. Insert the cleaning cartridge into the cleaning cartridge slot.

Orient the cartridge so its protrusion (1) is face up, and then, while keeping the cartridge level, insert the cartridge as far as it will go.

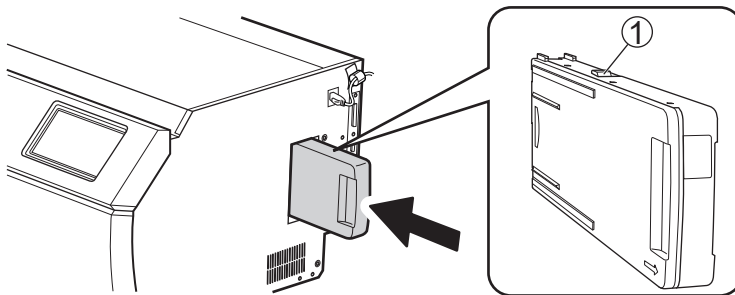

7. Tap [Yes] when the cleaning liquid pouch replacement confirmation screen appears.

If you tap [Yes] to reset the amount of cleaning liquid remaining, the cleaning liquid pouch will be identified as a new product.

MEMO

If you tap [Yes] on the cleaning liquid pouch replacement confirmation screen even though you have not replaced the cleaning liquid pouch, the amount of cleaning liquid remaining is reset. In this situation, no notification will appear even if the amount of cleaning liquid remaining is very small, and the message [Replace the cleaning liquid pouch.] will appear when the cleaning liquid runs out. To ensure you have enough time to prepare the replacement cleaning liquid, tap [No] if you have not replaced the cleaning liquid.

Output Method

Printing Method

Preparations for Printing Output	135
Step 1: Performing a Printing Test	135
Step 2: Performing Normal Cleaning	137
Starting Output	138

Preparations for Printing Output

Step 1: Performing a Printing Test

Before you carry out actual printing, perform a printing test to ensure no dot drop-out or dot displacement occurs. If dot drop-out or dot displacement occurs, perform cleaning of the print heads (normal cleaning).

MEMO

When performing printing tests successively, you can select [Feed] (vertical printing) or [Scan] (horizontal printing) as the print position for the second and later tests in comparison to the first test.









[P. 266 Performing Printing Tests Arranged Horizontally](#)

Procedure

1. Set up the media.
2. Tap  [Nozzle Drop-out Test] on the home screen.
3. Tap [Printing Test]>[Execute].
Printing of the test pattern starts.

MEMO

To change the start position for the printing test, configure the following settings.

1. Tap [Output Start Location]>[Change].
2. Tap .
The cutting carriage moves to the current base point.
3. Tap     and move the cutter center to the position where you want to start cutting.
Tap  or  to move the media in the feed direction (forward-back). Tap  or  to move the cutting carriage in the scan direction (left-right).

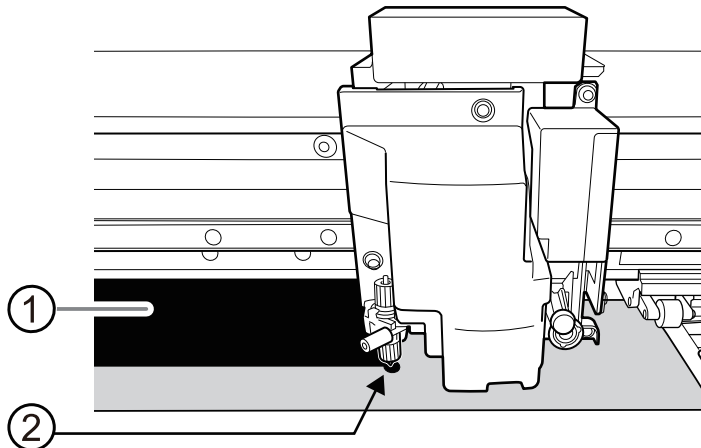

- ①: Printing area
 - ②: Base point (right edge of the printing area)
4. Once the position has been decided, tap [Set Base Point Here] to confirm it.
The base point position is updated.

4. Check whether there is dot drop-out or dot displacement in the test pattern.

Missing blocks indicate dot drop-out. Collapsed or inclined blocks indicate dot displacement.

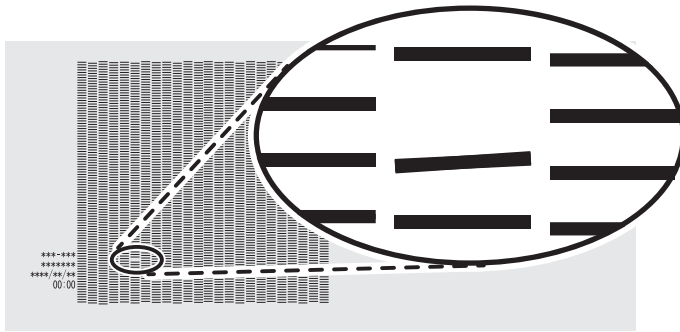

MEMO

If the printing-test results are difficult to interpret

Check the results in a bright location, changing your line of vision. They are visible using the reflection of the light.

5. If dot drop-out or dot displacement is present, perform normal cleaning.

[P. 137 Performing Normal Cleaning](#)

If there is no dot drop-out or dot displacement, proceed to the next step.

6. If you have opened the front cover, close it.

If no dot drop-out or dot displacement occurs, preparations for output are finished.

7. Tap  to return to the home screen.

RELATED LINKS

- [P. 318 When Dot Drop-out or Dot Displacement Occurs](#)

Step 2: Performing Normal Cleaning

MEMO

If the media has already been set up, the [After cleaning, perform a printing test.] menu appears on the [Normal Cleaning] screen. When this setting is turned on, a printing test is performed after cleaning.

Procedure

1. If the front cover is open, close it.
2. Tap [Cleaning].
3. Tap [Normal Cleaning].

The screen shown below appears.

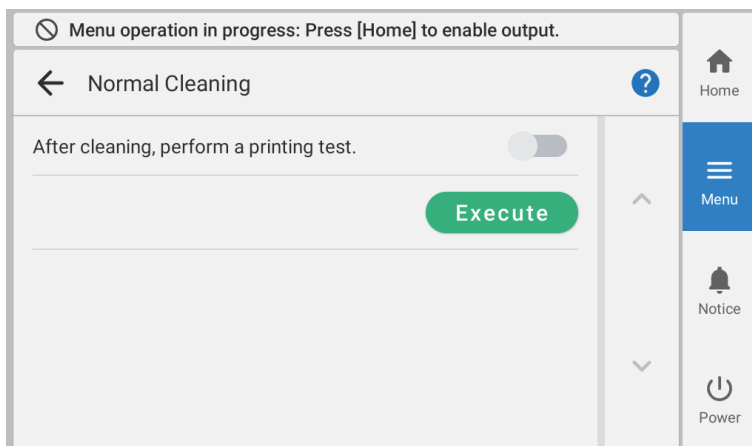

4. Tap [Execute].
Cleaning will start. The details of the operation in progress and the (approximate) remaining time of that work are displayed in the status bar at the top of the screen. When the work is finished, the status bar returns to its original display.
5. Tap ←.
6. Tap [Printing Test].
7. Tap [Nozzle Drop-out Test]>[Execute].
8. Check to make sure the dot drop-out or dot displacement has been corrected.
If the problem persists, try performing normal cleaning again. If the printer has been used for a long period, dot drop-outs may not be fixed even after performing normal cleaning two or three times. If this is the case, clean using a different method.
9. Tap  to return to the home screen.

RELATED LINKS

- [P. 296 Performing a Printing Test](#)
- [P. 320 When Normal Cleaning Is Not Effective](#)

Starting Output

⚠ WARNING

Never touch the print-head carriage while output is in progress.

The print-head carriage moves at high speed. Coming into contact with the moving carriage may cause injury.

⚠ CAUTION

Do not touch the dancer roller needlessly.

The media take-up unit and feeder may move suddenly, which may result in injury.

Procedure

1. Shake the ink cartridge at the times indicated below.

- White ink: Each day (before starting the day's operations).
- Ink other than white ink: When replaced with a new cartridge or when uneven color issues occur

Shake the ink cartridge 50 times (about 20 seconds), and then reinsert the cartridge. The precipitation of the ingredients in the ink disables printing in normal color. So that the ink mixes well, shake the ink cartridge horizontally with a stroke length of around 5 cm (1.97 in.) from each end of the ink cartridge.

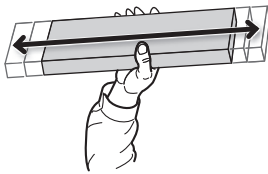

IMPORTANT

- **The ingredients in white ink tend to settle.**
Allowing the ink to stand without shaking it can cause the settled material to harden, resulting in malfunction or other problems.
- **Before shaking the ink cartridge, wipe off any ink from around its mouth.**
If you do not wipe off the ink, it may splatter when you shake the ink cartridge.
- **When you have finished mixing the ink, reattach the ink cartridge immediately.**
Taking time to reattach the ink cartridge will adversely affect the ink path.

2. Close the front cover.

3. Tap to return to the home screen.

4. Check that [Output possible.] is displayed in the status bar.

5. Send the output data from the computer.

For information on how to create the output data, refer to the documentation for the RIP software.

MEMO

- When you send the output data, [Normal cleaning in progress.] may be displayed on the screen. These indicate the preparation operations performed before output. Output will begin after the time displayed on the screen elapses.
- If [Heater warm up in progress. Please wait.] is displayed, wait until the set temperature is reached.
- The data being output can be viewed as an image. Tap  shown in the following figure to switch to the remaining ink screen. Tap it again to return to the screen for checking the data being output. However, this functionality is limited to RIP software that supports the display of the output data image (thumbnail).

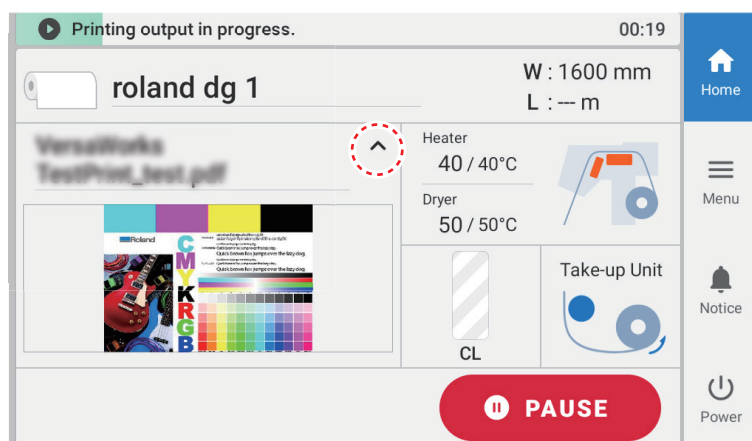

IMPORTANT

Output is not possible in these situations

- The machine does not run when a cover (front, left, or right) is open.
- Data from the computer is not accepted when [Load media.] is displayed.
- Output does not start while [Heater warm up in progress. Please wait.] is displayed.
- On menu screens where [Menu operation in progress: Press [Home] to enable output.] is displayed, output doesn't start even when data is sent from the computer. When you return to a menu item where output is possible or tap  to return to the home screen, output starts.

Points that must be observed

- Never open a cover (front, left, or right) while output is in progress. Doing so interrupts printing.
- When you are performing printing, clamp the edges of the media with the media clamps. Otherwise, the edges of the media may warp and catch on the print heads.
- During output, do not touch the media. Doing so may obstruct the media feed or cause the media to rub against the print heads, which may result in a paper jam or damage to the heads.
- Keep the loading lever raised when the machine is not in use.

When not using the machine, remove any media and store it in a suitable environment.

- If the machine is left with the media loaded, the media may be damaged, which may adversely affect printing. When not using the machine, remove any media and store it in a suitable environment.

RELATED LINKS

- [P. 190 Setting the Print Heater Temperature](#)
- [P. 192 Setting the Dryer Temperature](#)
- [P. 141 Switching Off the Print Heater and Dryer](#)

Cutting Method

Preparations for Cutting Output.....	141
Step 1: Switching Off the Print Heater and Dryer	141
Step 2: Preventing Pulling of the Media with Undue Force	142
Step 3: Adjusting Cutting	143
Starting Output	145

Preparations for Cutting Output

Step 1: Switching Off the Print Heater and Dryer

MEMO

This work is not necessary when [Cut Only] was selected for [Select Media Output Type], or when the media was created with [Duplicating Media Settings for Cutting](#) (P. 258).

Procedure

1. Set up the media.
2. Tap the following location.

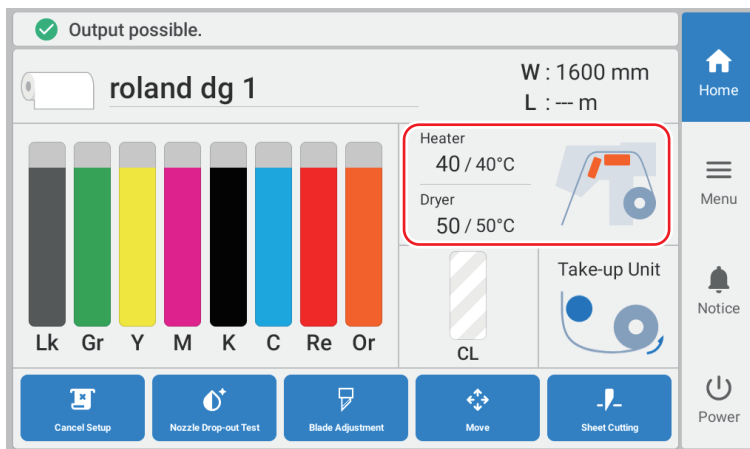

3. Tap [Heater Power] to turn it off as shown below.

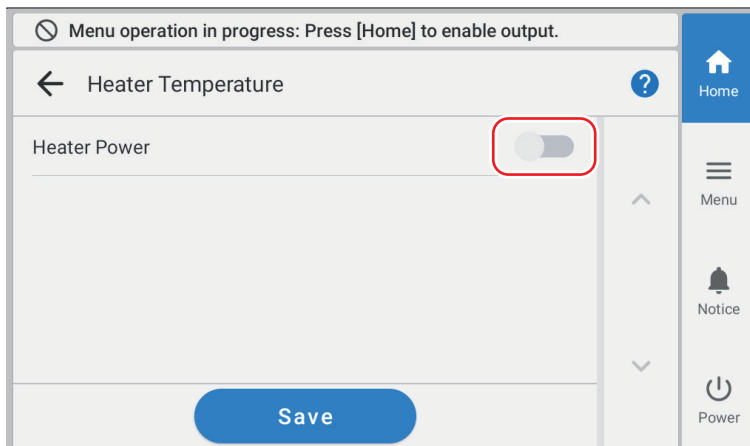



4. Tap [Save] to confirm your entry.
The [Print Heater] and [Dryer] settings turn off.
5. Tap  to return to the home screen.

Step 2: Preventing Pulling of the Media with Undue Force

Configure the settings shown below to prevent the media from being pulled forcibly and causing misalignment or distortion of the cut position when the printer pulls the media out such as for cutting.







Procedure

1. Tap .
2. Tap [Preferences]>[Prefeeding at Output].
3. Select [Enable].
4. Tap [Save] to confirm your entry.
5. Tap  to return to the home screen.

Step 3: Adjusting Cutting

For high-quality cutting, we recommend carrying out a cutting test to check the cutting quality for the media before you perform actual cutting. Adjust the blade force depending on the cutting quality.

Procedure

1. Tap  [Blade Adjustment] on the home screen.
2. Tap [Change] next to [Output Start Location].
3. Tap .
The cutting carriage moves to the current base point.
4. Tap , , , or  to move the cutting carriage to the location where you want to carry out the cutting test.
You can freely set the location for the cutting test.
5. Tap [Set Base Point Here].
6. Tap [Execute] next to [Cutting Test].
The test pattern is cut.
7. Peel off the cut shapes and change the [Blade Adjustment] settings according to the cutting quality.
Check that the two shapes are peeled off separately, a blade trace (red line) remains on the backing paper, and the backing paper is not cut.

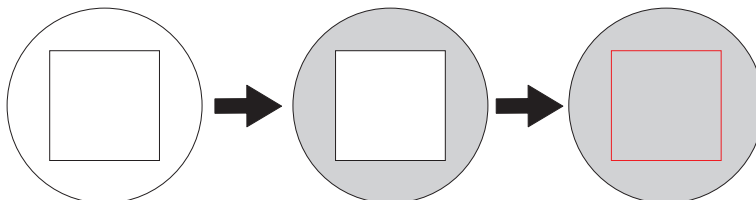

- **Two shapes are peeled off separately**
You do not need to perform the setting because the blade force is appropriate.
- **Two shapes are peeled off together**
Increase the blade force.
- **Backing paper is also cut**
Decrease the blade force.

8. Tap [Save].
The changed settings are saved.
9. Tap [Execute] next to [Cutting Test].
The test pattern is cut.
10. Check whether the correction was successful.

In the [Blade Adjustment] menu, you can also make settings for other cutting conditions in addition to the blade force.

RELATED LINKS

- [P. 200 Accurately Adjusting the Cutting Settings](#)

Starting Output

⚠ WARNING

Never touch the cutting carriage while output is in progress.
The cutting carriage moves at high speed. Coming into contact with the moving carriage may cause injury.

⚠ CAUTION

Do not touch the dancer roller needlessly.
The media take-up unit and feeder may move suddenly, which may result in injury.

Procedure

1. Close the front cover.
2. Tap  to display the home screen.
3. Check that [Output possible.] is displayed in the status bar.
4. Send the output data from the computer.
For information on how to create the output data, refer to the documentation for the RIP software.

MEMO

The data being output can be viewed as an image. Tap  shown in the following figure to switch to the remaining ink screen. Tap it again to return to the screen for checking the data being output. However, this functionality is limited to RIP software that supports the display of the output data image (thumbnail).

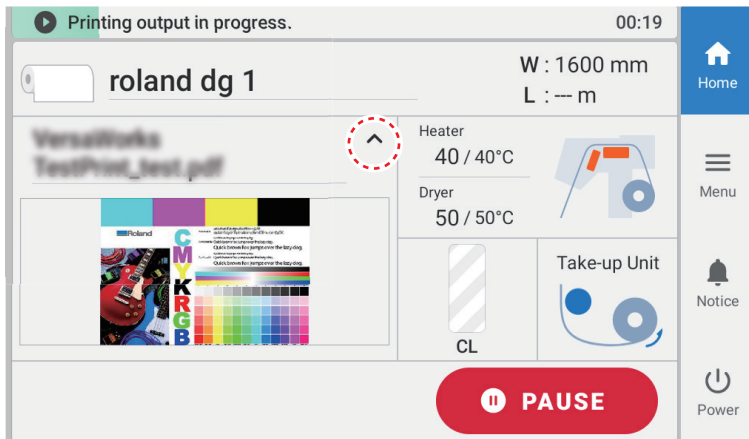

IMPORTANT

Output is not possible in these situations

- The machine does not run when a cover (front, left, or right) is open.
- Data from the computer is not accepted when [Load media.] is displayed.
- On menu screens where [Menu operation in progress: Press [Home] to enable output.] is displayed, output doesn't start even when data is sent from the computer. When you return to a menu item where output is possible or tap  to return to the home screen, output starts.

Points that must be observed

- Never open a cover (front, left, or right) while output is in progress. Doing so interrupts printing.
- During output, do not touch the media. Doing so may obstruct the media feed or cause the media to rub against the cutting carriage, which may result in a paper jam or damage to the carriage.
- Keep the loading lever raised when the machine is not in use.

When not using the machine, remove any media and store it in a suitable environment.

- If the machine is left with the media loaded, the media may be damaged, which may adversely affect printing. When not using the machine, remove any media and store it in a suitable environment.

Printing and Cutting Method

Preparations before Printing and Cutting Output.....	148
Step 1: Performing a Printing Test	148
Step 2: Performing Normal Cleaning	150
Step 3: Adjusting Cutting	151
Step 4: Correcting the Misalignment of Printing and Cutting.....	153
Starting Output	155

Preparations before Printing and Cutting Output

Step 1: Performing a Printing Test

Before you carry out actual printing, perform a printing test to ensure no dot drop-out or dot displacement occurs. If dot drop-out or dot displacement occurs, perform cleaning of the print heads (normal cleaning).

MEMO

When performing printing tests successively, you can select [Feed] (vertical printing) or [Scan] (horizontal printing) as the print position for the second and later tests in comparison to the first test.









[P. 266 Performing Printing Tests Arranged Horizontally](#)

Procedure

1. Set up the media.
2. Tap  [Nozzle Drop-out Test] on the home screen.
3. Tap [Printing Test]>[Execute].
Printing of the test pattern starts.

MEMO

To change the start position for the printing test, configure the following settings.

1. Tap [Output Start Location]>[Change].
2. Tap .
The cutting carriage moves to the current base point.
3. Tap     and move the cutter center to the position where you want to start cutting.
Tap  or  to move the media in the feed direction (forward-back). Tap  or  to move the cutting carriage in the scan direction (left-right).

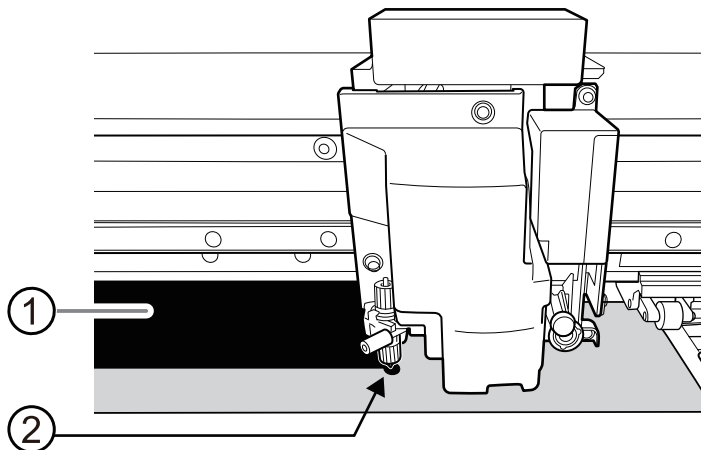

- ①: Printing area
 - ②: Base point (right edge of the printing area)
4. Once the position has been decided, tap [Set Base Point Here] to confirm it.
The base point position is updated.

4. Check whether there is dot drop-out or dot displacement in the test pattern.

Missing blocks indicate dot drop-out. Collapsed or inclined blocks indicate dot displacement.

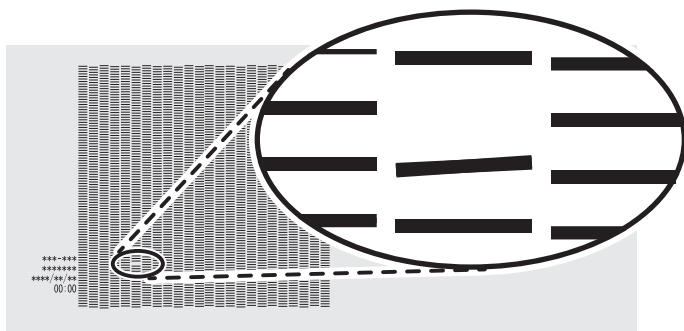
**MEMO**

If the printing-test results are difficult to interpret

Check the results in a bright location, changing your line of vision. They are visible using the reflection of the light.

5. If dot drop-out or dot displacement is present, perform normal cleaning.

[P. 150 Step 2: Performing Normal Cleaning](#)

If there is no dot drop-out or dot displacement, proceed to the next step.

6. If you have opened the front cover, close it.

If no dot drop-out or dot displacement occurs, preparations for output are finished.

7. Tap  to return to the home screen.

RELATED LINKS

- [P. 318 When Dot Drop-out or Dot Displacement Occurs](#)

Step 2: Performing Normal Cleaning

MEMO

If the media has already been set up, the [After cleaning, perform a printing test.] menu appears on the [Normal Cleaning] screen. When this setting is turned on, a printing test is performed after cleaning.

Procedure

1. If the front cover is open, close it.
2. Tap [Cleaning].
3. Tap [Normal Cleaning].

The screen shown below appears.

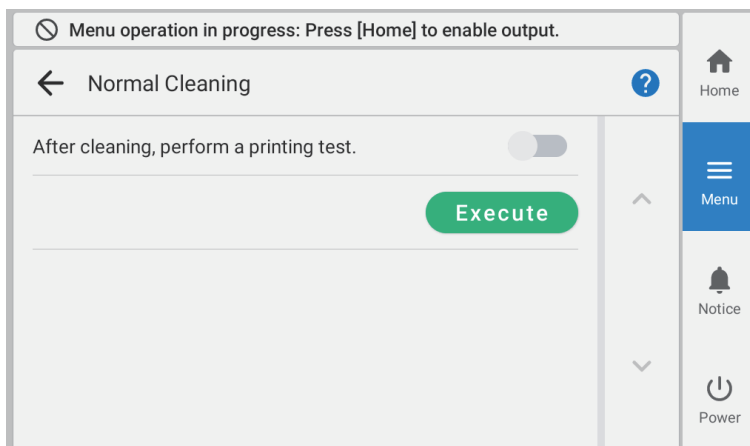







4. Tap [Execute].
Cleaning will start. The details of the operation in progress and the (approximate) remaining time of that work are displayed in the status bar at the top of the screen. When the work is finished, the status bar returns to its original display.
5. Tap ←.
6. Tap [Printing Test].
7. Tap [Nozzle Drop-out Test]>[Execute].
8. Check to make sure the dot drop-out or dot displacement has been corrected.
If the problem persists, try performing normal cleaning again. If the printer has been used for a long period, dot drop-outs may not be fixed even after performing normal cleaning two or three times. If this is the case, clean using a different method.
9. Tap 🏠 to return to the home screen.

Step 3: Adjusting Cutting

For high-quality cutting, we recommend carrying out a cutting test to check the cutting quality for the media before you perform actual cutting. Adjust the blade force depending on the cutting quality.

Procedure

1. Tap  [Blade Adjustment] on the home screen.
2. Tap [Change] next to [Output Start Location].
3. Tap .
The cutting carriage moves to the current base point.
4. Tap , , , or  to move the cutting carriage to the location where you want to carry out the cutting test.
You can freely set the location for the cutting test.
5. Tap [Set Base Point Here].
6. Tap [Execute] next to [Cutting Test].
The test pattern is cut.
7. Peel off the cut shapes and change the [Blade Adjustment] settings according to the cutting quality.
Check that the two shapes are peeled off separately, a blade trace (red line) remains on the backing paper, and the backing paper is not cut.

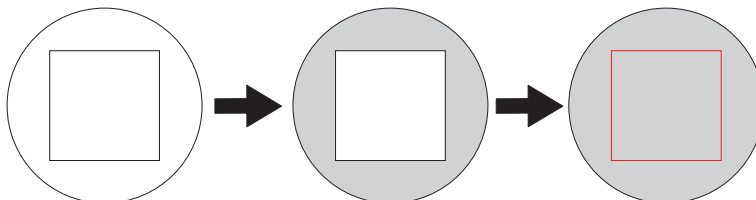

- **Two shapes are peeled off separately**
You do not need to perform the setting because the blade force is appropriate.
- **Two shapes are peeled off together**
Increase the blade force.
- **Backing paper is also cut**
Decrease the blade force.

8. Tap [Save].
The changed settings are saved.
9. Tap [Execute] next to [Cutting Test].
The test pattern is cut.
10. Check whether the correction was successful.

In the [Blade Adjustment] menu, you can also make settings for other cutting conditions in addition to the blade force.

RELATED LINKS

- [P. 200 Accurately Adjusting the Cutting Settings](#)

Step 4: Correcting the Misalignment of Printing and Cutting

Procedure

1. Tap .
2. Tap [Media Settings]>[Cutting Settings]>[Print & Cut Position Adjustment].
3. Tap [Execute] next to [Printing Test 1(Misalignment Check)].
Printing Test 1 is printed and cut. The test pattern is printed at each edge of the media.

MEMO

If the media is tilted, the positions at the edges will be misaligned. You can also adjust for misalignments due to the media being tilted by printing the test pattern at each edge.

4. Check the result of Printing Test 1.

Check whether the printing position (shaded part) and the cutting position (red line) are aligned. An example of the printing position and the cutting position being misaligned is shown in the following figure.

[F] indicates the feed direction of the media (the feed direction) and [S] indicates the direction of print head carriage movement (the scan direction).

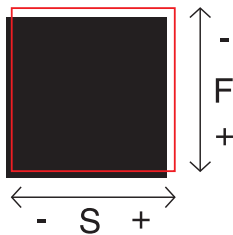

If the printing position and the cutting position are aligned, no corrections are necessary. Proceed to step 10.

If the printing position and the cutting position are not aligned, proceed to the next procedure.

5. Tap [Execute] next to [Printing Test 2(Correction Values)].
Printing Test 2 is printed and cut.
6. Check the correction values from the Printing Test 2 condition.
The point where the cutting line (A) intersects the correction-value scale (B) is the correction value. In the following figure, the correction value is "-0.3."
Check the media feed direction (the feed direction) and the direction of print-head carriage movement (the scan direction).

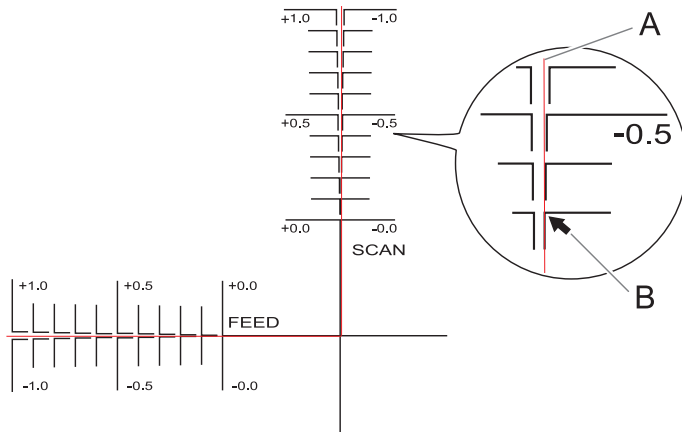

7. Set the correction values in the feed direction of the media (the feed direction) and the direction of print-head carriage movement (the scan direction).
 - (1) Tap **-** or **+** next to [Correction Value (Feed)] to set the correction value in the feed direction of the media (the feed direction).
 - (2) Tap **-** or **+** next to [Correction Value (Scan)] to set the correction value in the direction of print head carriage movement (the scan direction).

8. Tap [Save].
The correction values are saved.

9. Tap [Execute] next to [Printing Test 1(Misalignment Check)].
Printing Test 1 is printed and cut. If the printing and cutting lines are aligned, adjustment is complete. If further adjustment is needed, tap **-** or **+** next to [Correction Value (Feed)] and [Correction Value (Scan)] to fine-tune the printing and cutting position, and then [Save] the values.

MEMO

Default settings

- [Correction Value (Feed)] (correction value of the media feed direction): 0.00 mm
- [Correction Value (Scan)] (correction value of the print-head carriage movement direction): 0.00 mm

10. Tap  to return to the home screen.

Starting Output

⚠ WARNING

Never touch the print-head carriage while output is in progress.

The print-head carriage moves at high speed. Coming into contact with the moving carriage may cause injury.

⚠ CAUTION

Do not touch the dancer roller needlessly.

The media take-up unit and feeder may move suddenly, which may result in injury.

Procedure

1. Shake the ink cartridge at the times indicated below.

- White ink: Each day (before starting the day's operations).
- Ink other than white ink: When replaced with a new cartridge or when uneven color issues occur

Shake the ink cartridge 50 times (about 20 seconds), and then reinsert the cartridge. The precipitation of the ingredients in the ink disables printing in normal color. So that the ink mixes well, shake the ink cartridge horizontally with a stroke length of around 5 cm (1.97 in.) from each end of the ink cartridge.

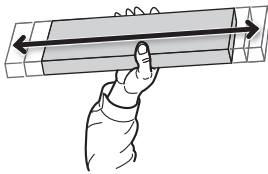

IMPORTANT

- **The ingredients in white ink tend to settle.**
Allowing the ink to stand without shaking it can cause the settled material to harden, resulting in malfunction or other problems.
- **Before shaking the ink cartridge, wipe off any ink from around its mouth.**
If you do not wipe off the ink, it may splatter when you shake the ink cartridge.
- **When you have finished mixing the ink, reattach the ink cartridge immediately.**
Taking time to reattach the ink cartridge will adversely affect the ink path.

2. Close the front cover.

3. Tap to return to the home screen.

4. Check that [Output possible.] is displayed in the status bar.

5. Send the output data from the computer.

For information on how to create the output data, refer to the documentation for the RIP software.

MEMO

- When you send the output data, [Normal cleaning in progress.] may be displayed on the screen. These indicate the preparation operations performed before output. Output will begin after the time displayed on the screen elapses.
- If [Heater warm up in progress. Please wait.] is displayed, wait until the set temperature is reached.
- The data being output can be viewed as an image. Tap  shown in the following figure to switch to the remaining ink screen. Tap it again to return to the screen for checking the data being output. However, this functionality is limited to RIP software that supports the display of the output data image (thumbnail).

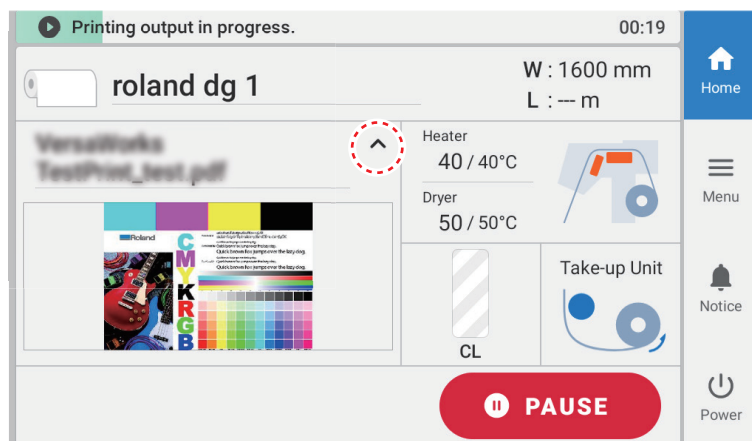

IMPORTANT

Output is not possible in these situations

- The machine does not run when a cover (front, left, or right) is open.
- Data from the computer is not accepted when [Load media.] is displayed.
- Output does not start while [Heater warm up in progress. Please wait.] is displayed.
- On menu screens where [Menu operation in progress: Press [Home] to enable output.] is displayed, output doesn't start even when data is sent from the computer. When you return to a menu item where output is possible or tap  to return to the home screen, output starts.

Points that must be observed

- Never open a cover (front, left, or right) while output is in progress. Doing so interrupts printing.
- When you are performing printing, clamp the edges of the media with the media clamps. Otherwise, the edges of the media may warp and catch on the print heads.
- During output, do not touch the media. Doing so may obstruct the media feed or cause the media to rub against the print heads, which may result in a paper jam or damage to the heads.
- Keep the loading lever raised when the machine is not in use.

When not using the machine, remove any media and store it in a suitable environment.

- If the machine is left with the media loaded, the media may be damaged, which may adversely affect printing. When not using the machine, remove any media and store it in a suitable environment.

RELATED LINKS

- [P. 190 Setting the Print Heater Temperature](#)
- [P. 192 Setting the Dryer Temperature](#)
- [P. 141 Switching Off the Print Heater and Dryer](#)

How to Cut with Crop Marks

Preparations before Cutting with Crop Marks	158
Step 1: Performing a Printing Test	158
Step 2: Performing Normal Cleaning	160
Step 3: Adjusting Cutting	161
Step 4: Correct the misalignment of printing and cutting with crop marks at the same time.	163
Starting Printing Output with Crop Marks	165
Preparations for Cutting Output.....	168
Step 1: Setting Up Media with Crop Marks	168
Step 2: Switching Off the Print Heater and Dryer	169
Step 3: Preventing Pulling of the Media with Undue Force	170
Starting Cutting Output.....	171

Preparations before Cutting with Crop Marks

What Is Cutting with Crop Marks?

If you are removing the printed media and setting it up again in order to cut it (for example, if you are processing the media, such as laminating after printing, and then setting up this media again for cutting), you have to align the printing and cutting positions. By printing the data together with crop marks, you can make it possible to align the positions using the crop marks when you set up the media again to cut it. In this manual, this printing method is referred to as "cutting with crop marks."

"Crop marks" are marks used to align positions. They are also called "alignment marks."

Step 1: Performing a Printing Test

Before you carry out actual printing, perform a printing test to ensure no dot drop-out or dot displacement occurs. If dot drop-out or dot displacement occurs, perform cleaning of the print heads (normal cleaning).

MEMO

When performing printing tests successively, you can select [Feed] (vertical printing) or [Scan] (horizontal printing) as the print position for the second and later tests in comparison to the first test.









[P. 266 Performing Printing Tests Arranged Horizontally](#)

Procedure

1. Set up the media.
2. Tap  [Nozzle Drop-out Test] on the home screen.
3. Tap [Printing Test]>[Execute].
Printing of the test pattern starts.

MEMO

To change the start position for the printing test, configure the following settings.

1. Tap [Output Start Location]>[Change].
2. Tap .
The cutting carriage moves to the current base point.
3. Tap     and move the cutter center to the position where you want to start cutting.
Tap  or  to move the media in the feed direction (forward-back). Tap  or  to move the cutting carriage in the scan direction (left-right).

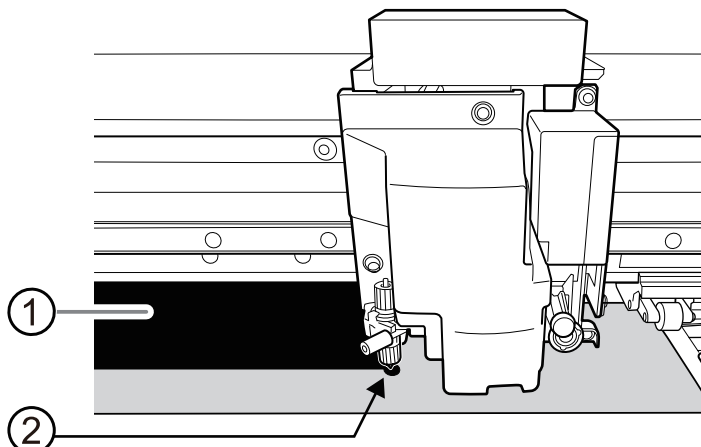

- ①: Printing area
 - ②: Base point (right edge of the printing area)
4. Once the position has been decided, tap [Set Base Point Here] to confirm it.
The base point position is updated.

4. Check whether there is dot drop-out or dot displacement in the test pattern.
Missing blocks indicate dot drop-out. Collapsed or inclined blocks indicate dot displacement.

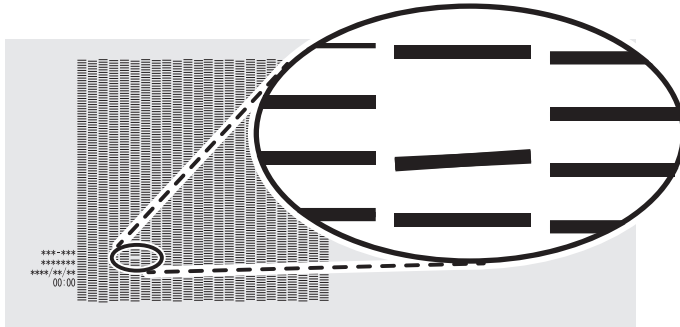

MEMO

If the printing-test results are difficult to interpret
Check the results in a bright location, changing your line of vision. They are visible using the reflection of the light.

5. If dot drop-out or dot displacement is present, perform normal cleaning.
[P. 160 Step 2: Performing Normal Cleaning](#)
If there is no dot drop-out or dot displacement, proceed to the next step.
6. If you have opened the front cover, close it.
If no dot drop-out or dot displacement occurs, preparations for output are finished.
7. Tap  to return to the home screen.

RELATED LINKS

- [P. 318 When Dot Drop-out or Dot Displacement Occurs](#)

Step 2: Performing Normal Cleaning

MEMO

If the media has already been set up, the [After cleaning, perform a printing test.] menu appears on the [Normal Cleaning] screen. When this setting is turned on, a printing test is performed after cleaning.

Procedure

1. If the front cover is open, close it.

2. Tap [Cleaning].

3. Tap [Normal Cleaning].

The screen shown below appears.

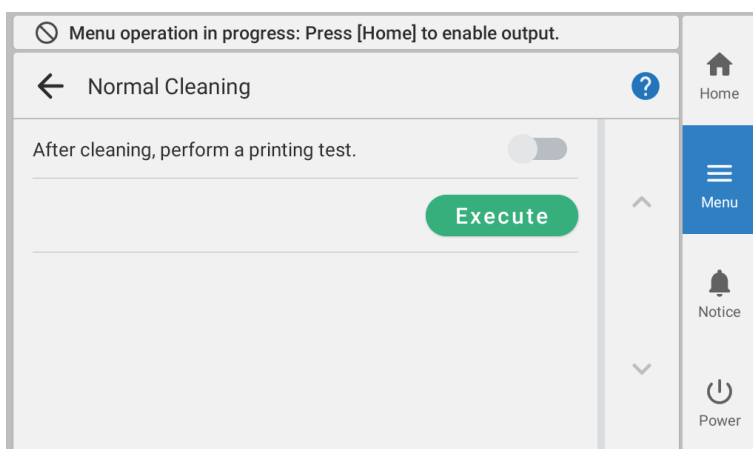

4. Tap [Execute].

Cleaning will start. The details of the operation in progress and the (approximate) remaining time of that work are displayed in the status bar at the top of the screen. When the work is finished, the status bar returns to its original display.

5. Tap ←.

6. Tap [Printing Test].

7. Tap [Nozzle Drop-out Test]>[Execute].

8. Check to make sure the dot drop-out or dot displacement has been corrected.

If the problem persists, try performing normal cleaning again. If the printer has been used for a long period, dot drop-outs may not be fixed even after performing normal cleaning two or three times. If this is the case, clean using a different method.

9. Tap  to return to the home screen.







RELATED LINKS

- [P. 296 Performing a Printing Test](#)
- [P. 320 When Normal Cleaning Is Not Effective](#)

Step 3: Adjusting Cutting

For high-quality cutting, we recommend carrying out a cutting test to check the cutting quality for the media before you perform actual cutting. Adjust the blade force depending on the cutting quality.

Procedure

1. Tap  [Blade Adjustment] on the home screen.
2. Tap [Change] next to [Output Start Location].
3. Tap .
The cutting carriage moves to the current base point.
4. Tap , , , or  to move the cutting carriage to the location where you want to carry out the cutting test.
You can freely set the location for the cutting test.
5. Tap [Set Base Point Here].
6. Tap [Execute] next to [Cutting Test].
The test pattern is cut.
7. Peel off the cut shapes and change the [Blade Adjustment] settings according to the cutting quality.
Check that the two shapes are peeled off separately, a blade trace (red line) remains on the backing paper, and the backing paper is not cut.

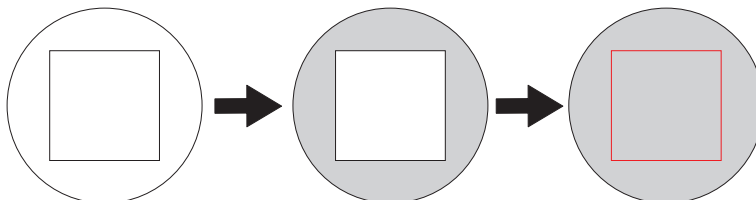

- **Two shapes are peeled off separately**
You do not need to perform the setting because the blade force is appropriate.
- **Two shapes are peeled off together**
Increase the blade force.
- **Backing paper is also cut**
Decrease the blade force.

8. Tap [Save].
The changed settings are saved.
9. Tap [Execute] next to [Cutting Test].
The test pattern is cut.
10. Check whether the correction was successful.

In the [Blade Adjustment] menu, you can also make settings for other cutting conditions in addition to the blade force.



RELATED LINKS

- [P. 200 Accurately Adjusting the Cutting Settings](#)

Step 4: Correct the misalignment of printing and cutting with crop marks at the same time.

Use the following procedure to print the crop marks and cut the media, checking for misalignment in the positions. In this section, the crop marks are printed simply, and then the crop marks are read and a cutting test is performed without removing the media. To simulate the actual process—printing crop marks, removing the media, and then performing post-processing such as laminating—before loading the media and checking for cutting position misalignment, turn on **[Separate Test for Printing/Cutting with Crop Marks]**. For more information, refer to [Correcting the Misalignment of Printing and Cutting with Crop Marks \(Separate Test for Printing and Cutting with Crop Marks\)\(P. 215\)](#).

Procedure

1. Tap .
2. Tap **[Media Settings]>[Cutting Settings]>[Crop Cut Position Adjustment]**.
3. Tap  next to **[Separate Test for Printing/Cutting with Crop Marks]** to turn it off.
4. Tap **[Execute]** next to **[Printing Test 1(Misalignment Check)]**.
Printing Test 1 is printed and cut. One test pattern is printed on the media.

IMPORTANT

Printing (crop marks) may not be readable with transparent media, silver or other light-reflective media, or black or other dark-colored media, which may prevent cutting from being performed. Try the following if **[Crop Mark Detection Error]** is displayed.

- [Are you using transparent media?\(P. 368\)](#)
- [Are you using media that is likely to reflect light or has deep colors?\(P. 368\)](#)

5. **Check Printing Test 1.**

Check whether the printing position (shaded part) and the cutting position (red line) are aligned. An example of the printing position and the cutting position being misaligned is shown in the following figure.

[F] indicates the feed direction of the media (the feed direction) and [S] indicates the direction of print head carriage movement (the scan direction).

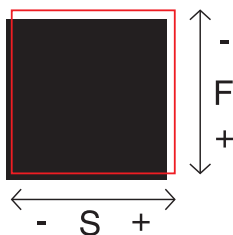

If the printing position and the cutting position are aligned, no corrections are necessary. Proceed to step 11.

If the printing position and the cutting position are not aligned, proceed to the next procedure.

6. Tap **[Execute]** next to **[Printing Test 2(Correction Values)]**.
Printing Test 2 is printed and cut.
7. **Check the correction values from the Printing Test 2 condition.**

The point where the cutting line (A) intersects the correction-value scale (B) is the correction value. In the following figure, the correction value is "-0.3."

Check the media feed direction (the feed direction) and the direction of print-head carriage movement (the scan direction).

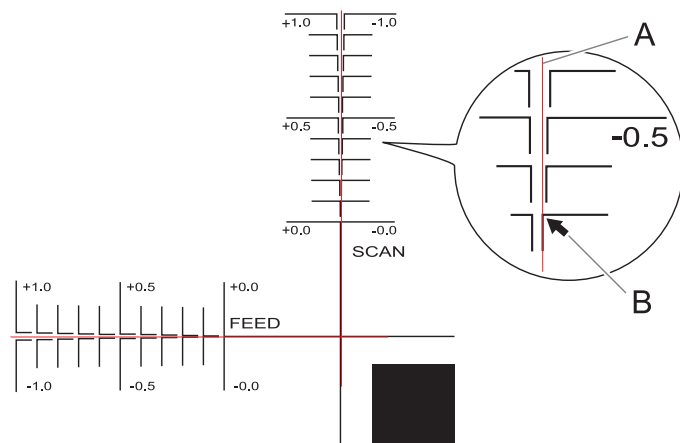

8. Set the correction values in the feed direction of the media (the feed direction) and the direction of print-head carriage movement (the scan direction).
 - (1) Tap **-** or **+** next to [Correction Value (Feed)] to set the correction value in the feed direction of the media (the feed direction).
 - (2) Tap **-** or **+** next to [Correction Value (Scan)] to set the correction value in the direction of print head carriage movement (the scan direction).
9. Tap [Save].
The correction values are saved.
10. Tap [Execute] next to [Printing Test 1(Misalignment Check)].
Printing Test 1 is printed and cut. If the printing and cutting lines are aligned, adjustment is complete. If further adjustment is needed, tap **-** or **+** next to [Correction Value (Feed)] and [Correction Value (Scan)] to fine-tune the printing and cutting position, and then [Save] the values.

MEMO

- Default setting
 [Correction Value (Feed)] (correction value of the media feed direction): 0.00 mm (0.00 in.)
 [Correction Value (Scan)] (correction value of the print-head carriage movement direction): 0.00 mm (0.00 in.)
- Depending on the changes in the condition of media caused by laminating and the loading position of the media before cutting, the positioning of cutting may be misaligned. In such cases, correct the misalignment of printing and cutting with crop marks.

11. Tap  to return to the home screen.

RELATED LINKS

- [P. 215 Correcting the Misalignment of Printing and Cutting with Crop Marks \(Separate Test for Printing and Cutting with Crop Marks\)](#)

Starting Printing Output with Crop Marks

⚠ WARNING

Never touch the print-head carriage while output is in progress.

The print-head carriage moves at high speed. Coming into contact with the moving carriage may cause injury.

⚠ CAUTION

Do not touch the dancer roller needlessly.

The media take-up unit and feeder may move suddenly, which may result in injury.

MEMO

When printing with crop marks, a printing area for printing the crop marks (①) and a margin for cropping and cutting must be secured.

- Crop mark printing area
Secure a crop mark printing area (A) of 22.5 mm (0.89 in.) both before and after the print data when printing crop marks.
- Margin for cropping and cutting
A margin of at least 75 mm (2.96 in.) before the crop marks (B) and at least 130 mm (5.12 in.) after the crop marks (C) are required in addition to the printing area required for reading and printing crop marks.

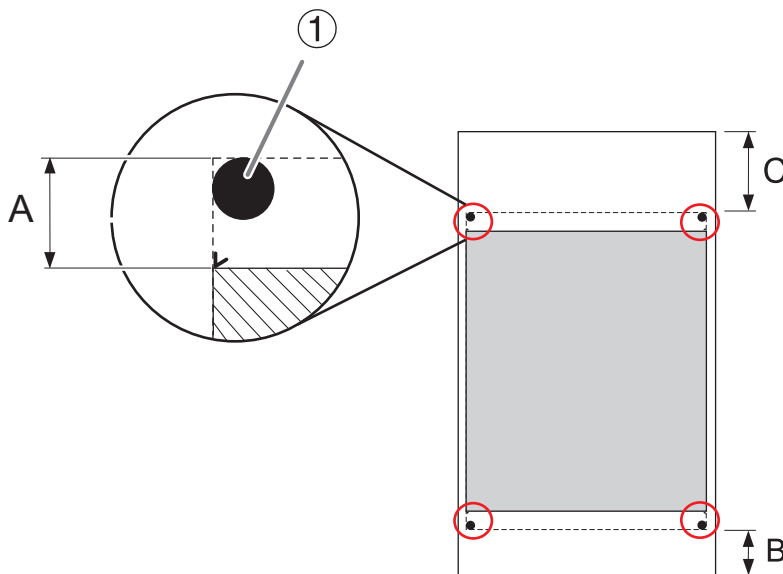

Procedure

1. Shake the ink cartridge at the times indicated below.

- White ink: Each day (before starting the day's operations).
- Ink other than white ink: When replaced with a new cartridge or when uneven color issues occur

Shake the ink cartridge 50 times (about 20 seconds), and then reinsert the cartridge. The precipitation of the ingredients in the ink disables printing in normal color. So that the ink mixes well,

shake the ink cartridge horizontally with a stroke length of around 5 cm (1.97 in.) from each end of the ink cartridge.

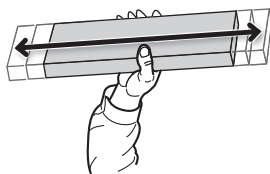

IMPORTANT

- **The ingredients in white ink tend to settle.**
Allowing the ink to stand without shaking it can cause the settled material to harden, resulting in malfunction or other problems.
- **Before shaking the ink cartridge, wipe off any ink from around its mouth.**
If you do not wipe off the ink, it may splatter when you shake the ink cartridge.
- **When you have finished mixing the ink, reattach the ink cartridge immediately.**
Taking time to reattach the ink cartridge will adversely affect the ink path.

2. Close the front cover.

3. Tap  to return to the home screen.

4. Check that [Output possible.] is displayed in the status bar.

5. Send the output data with crop marks from the computer.

For information on how to create the output data, refer to the documentation for the RIP software.

MEMO

- When you send the output data, [Normal cleaning in progress.] may be displayed on the screen. These indicate the preparation operations performed before output. Output will begin after the time displayed on the screen elapses.
- If [Heater warm up in progress. Please wait.] is displayed, wait until the set temperature is reached.
- The data being output can be viewed as an image. Tap  shown in the following figure to switch to the remaining ink screen. Tap it again to return to the screen for checking the data being output. However, this functionality is limited to RIP software that supports the display of the output data image (thumbnail).

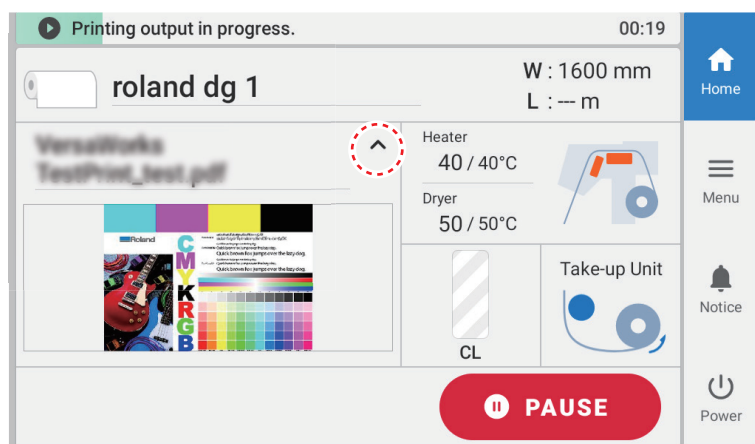

IMPORTANT**Output is not possible in these situations**

- The machine does not run when a cover (front, left, or right) is open.
- Data from the computer is not accepted when [Load media.] is displayed.
- Output does not start while [Heater warm up in progress. Please wait.] is displayed.
- On menu screens where [Menu operation in progress: Press [Home] to enable output.] is displayed, output doesn't start even when data is sent from the computer. When you return to a menu item where output is possible or tap  to return to the home screen, output starts.

Points that must be observed

- Never open a cover (front, left, or right) while output is in progress. Doing so interrupts printing.
- When you are performing printing, clamp the edges of the media with the media clamps. Otherwise, the edges of the media may warp and catch on the print heads.
- During output, do not touch the media. Doing so may obstruct the media feed or cause the media to rub against the print heads, which may result in a paper jam or damage to the heads.
- Keep the loading lever raised when the machine is not in use.

When not using the machine, remove any media and store it in a suitable environment.

- If the machine is left with the media loaded, the media may be damaged, which may adversely affect printing. When not using the machine, remove any media and store it in a suitable environment.

RELATED LINKS

- [P. 190 Setting the Print Heater Temperature](#)
- [P. 192 Setting the Dryer Temperature](#)
- [P. 141 Switching Off the Print Heater and Dryer](#)

Preparations for Cutting Output

Step 1: Setting Up Media with Crop Marks

Procedure

1. Load the media on which crop marks have been printed.

Place the front left and right crop marks so they are straight and aligned with the blade protector (A).

IMPORTANT

Ensure that the crop marks are not angled by more than 5 degrees. Crop marks cannot be read at higher angles.

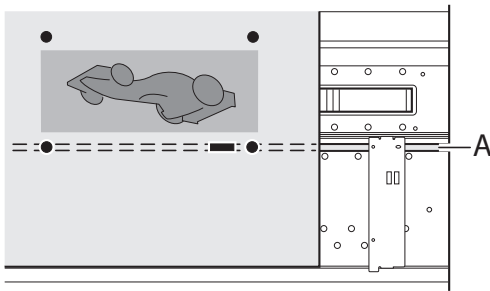

2. Finish the media setup and check that the home screen is displayed.

This completes the setup of the media with crop marks. Proceed to [Step 1: Switching Off the Print Heater and Dryer \(P. 141\)](#).

RELATED LINKS

- [P. 33 Setup of New Media](#)
- [P. 77 Setup of Registered Media](#)

Step 2: Switching Off the Print Heater and Dryer

MEMO

This work is not necessary when [Cut Only] was selected for [Select Media Output Type], or when the media was created with [Duplicating Media Settings for Cutting \(P. 258\)](#).

Procedure

1. Set up the media.
2. Tap the following location.

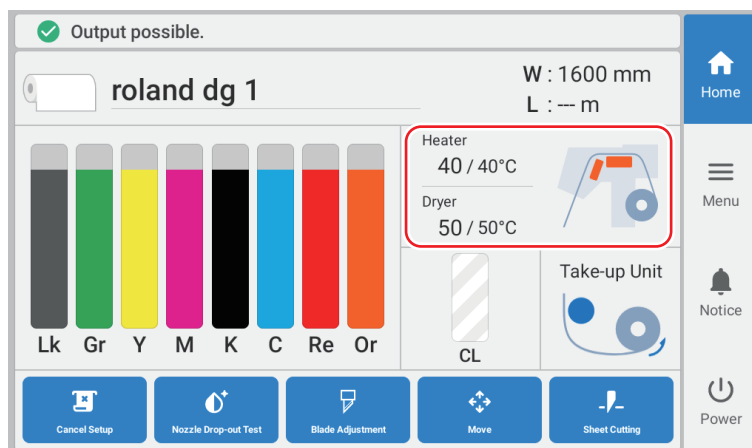

3. Tap [Heater Power] to turn it off as shown below.

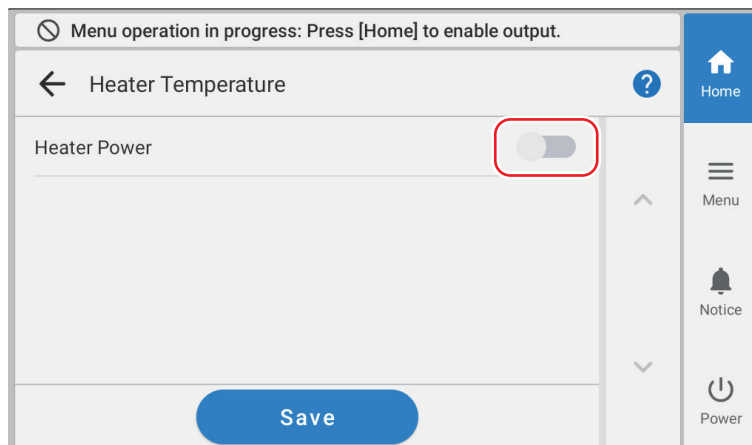



4. Tap [Save] to confirm your entry.
The [Print Heater] and [Dryer] settings turn off.
5. Tap  to return to the home screen.

Step 3: Preventing Pulling of the Media with Undue Force

Configure the settings shown below to prevent the media from being pulled forcibly and causing misalignment or distortion of the cut position when the printer pulls the media out such as for cutting.

Procedure

1. Tap .
2. Tap [Preferences]>[Prefeeding at Output].
3. Select [Enable].
4. Tap [Save] to confirm your entry.
5. Tap  to return to the home screen.

Starting Cutting Output

⚠ WARNING

Never touch the cutting carriage while output is in progress.

The cutting carriage moves at high speed. Coming into contact with the moving carriage may cause injury.

⚠ CAUTION

Do not touch the dancer roller needlessly.

The media take-up unit and feeder may move suddenly, which may result in injury.

Procedure

1. Close the front cover.
2. Tap  to display the home screen.
3. Check that [Output possible.] is displayed in the status bar.
4. Send the output data from the computer.

For information on how to create the output data, refer to the documentation for the RIP software.

MEMO

The data being output can be viewed as an image. Tap  shown in the following figure to switch to the remaining ink screen. Tap it again to return to the screen for checking the data being output. However, this functionality is limited to RIP software that supports the display of the output data image (thumbnail).

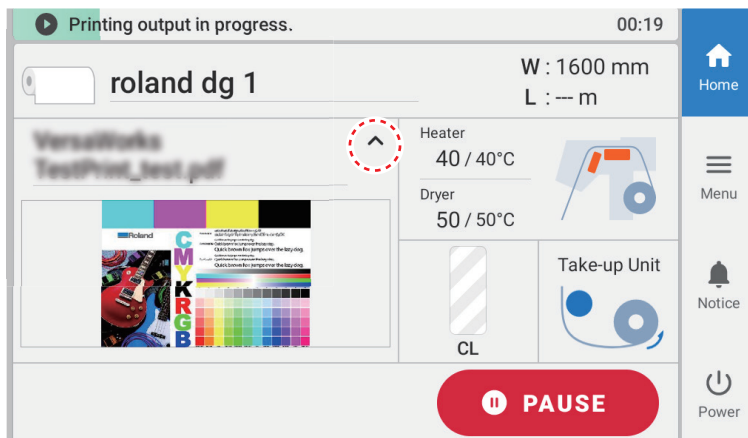

IMPORTANT

Output is not possible in these situations

- The machine does not run when a cover (front, left, or right) is open.
- Data from the computer is not accepted when [Load media.] is displayed.
- On menu screens where [Menu operation in progress: Press [Home] to enable output.] is displayed, output doesn't start even when data is sent from the computer. When you return to a menu item where output is possible or tap  to return to the home screen, output starts.

Points that must be observed

- Never open a cover (front, left, or right) while output is in progress. Doing so interrupts printing.
- During output, do not touch the media. Doing so may obstruct the media feed or cause the media to rub against the print heads, which may result in a paper jam or damage to the heads.
- Keep the loading lever raised when the machine is not in use.

When not using the machine, remove any media and store it in a suitable environment.

- If the machine is left with the media loaded, the media may be damaged, which may adversely affect printing. When not using the machine, remove any media and store it in a suitable environment.

Optimizing Quality and Efficiency

Optimizing the Output Quality

Using the Correction Functions.....	175
Automatically Making Required Adjustments	175
Manual Adjustment: Reducing Horizontal Bands (Feed Correction)	176
Manual Adjustment: Adjusting the Misalignment of the Ink Landing Position (Media Gap Adjustment).....	178
Configuring Settings to Match the Properties of the Media	180
Changing the Print Head Height	180
Using Hard-to-Dry Media	182
Using Media That Wrinkles Easily/Does Not Move Smoothly.....	183
Using Sticky Media	184
Take-up Unit Settings	185
Setting the Take-up Unit	185
Preventing Misaligned Media.....	187
Use Middle Pinch Rollers When Pulling Back or Feeding Media	187
Adjusting the Ink-drying Method	188
What Is the Media Heating System?	188
Setting the Print Heater Temperature	190
Setting the Dryer Temperature.....	192
Hints and Tips for Temperature Control	194
Setting the Temperature during Standby.....	195
Drying the Trailing Edge of the Printing Area on the Dryer.....	196
Switching Off the Print Heater and Dryer Together.....	197
Using an Auxiliary Drying Unit (DU3)	199
Accurately Adjusting the Cutting Settings.....	200
Fine-tuning the Cutting Conditions.....	200
Adjusting the Amount of Blade Extension	202
Performing Distance Correction during Cutting	204
Cutting to Make It Possible to Cut Corners Attractively (Over Cut)	205
Prioritizing the Cutting Settings of This Machine over the RIP Software Settings....	206
Accurately Adjusting the Settings for Printing and Cutting	207
Correcting the Misalignment of Printing and Cutting	207
Correcting the Misalignment of the Printing and Cutting Positions during Cutting ..	210
Accurately Adjusting the Settings for Cutting with Crop Marks	212
Correcting the Misalignment of Printing and Cutting with Crop Marks (Concur- rent Test for Printing and Cutting with Crop Marks).....	212
Correcting the Misalignment of Printing and Cutting with Crop Marks (Sepa- rate Test for Printing and Cutting with Crop Marks).....	215
Correcting the Reading Sensor	220

Using the Correction Functions

To optimize the output quality, it is effective to use some correction functions.

Automatically Making Required Adjustments

To optimize the output quality, corrections must match the media and printing conditions.

Depending on the printing conditions, the ink landing position may be misaligned and the movement distance may change subtly during media feeding. Automatically correct these issues to match the media.

First, print a test pattern. Then read this pattern with the multi sensor and automatically enter the correction values.

Executing automatic correction prints a test pattern, reads this pattern, and enters the correction values for the following operations.

- Multi sensor adjustment (adjusting to the optimal condition the sensor used in correction)
- Media gap adjustment (correcting the ink landing position)
- Feed correction (to reduce horizontal bands)

MEMO

The printing test width is approximately 290 mm (11.42 in.). Check that a printing area which can be printed has been secured, then perform the printing test.

Procedure

1. Set up the media.
2. Close the front cover.
3. Tap .
4. Tap [Media Settings]>[Printing Settings]>[Batch Automatic Correction].
5. Tap [Execute].

Test patterns are printed and correction values are entered for the following operations.

 - Multi Sensor Adjustment
 - Feed Correction
 - Media Gap Adjustment
6. Tap [OK] when the completion screen appears.
7. Perform the operations shown below according to the [Result].
 - If [Successful] is displayed on the operation panel, tap  to go back to the home screen.
 - If [Failed] is displayed on the operation panel, carry out manual adjustment.

RELATED LINKS

- [P. 176 Manual Adjustment: Reducing Horizontal Bands \(Feed Correction\)](#)
- [P. 178 Manual Adjustment: Adjusting the Misalignment of the Ink Landing Position \(Media Gap Adjustment\)](#)

Manual Adjustment: Reducing Horizontal Bands (Feed Correction)

Perform corrections to make the band-shaped "stripes" on the printed surface less noticeable.

The band-shaped "stripes" are called "horizontal bands" or "banding." Horizontal bands are caused by the subtle changes in the movement distance that occur when feeding the media depending on the media's thickness and the temperature of the front heater. We recommend that you make corrections to match the media you are using and the set temperature of the front heater.

First, print a test pattern, and then determine and enter the correction value. After entering the correction value, print a test pattern again and check the correction results. Repeat the process of printing a test pattern and entering a correction value several times to find the optimal correction value.

MEMO

The printing test width is approximately 375 mm (14.76 in.). Check that a printing area which can be printed has been secured, then perform the printing test.

Procedure

1. Set up the media.
2. Close the front cover.
3. Tap .
4. Tap [Media Settings]>[Printing Settings]>[Feed Correction].
5. Select [Detailed Correction (Manual)] and tap [Next].



6. Tap [Printing Test]>[Execute].
Printing of the test pattern starts.

7. Check the printed test pattern, and then tap  or  to change the correction value.

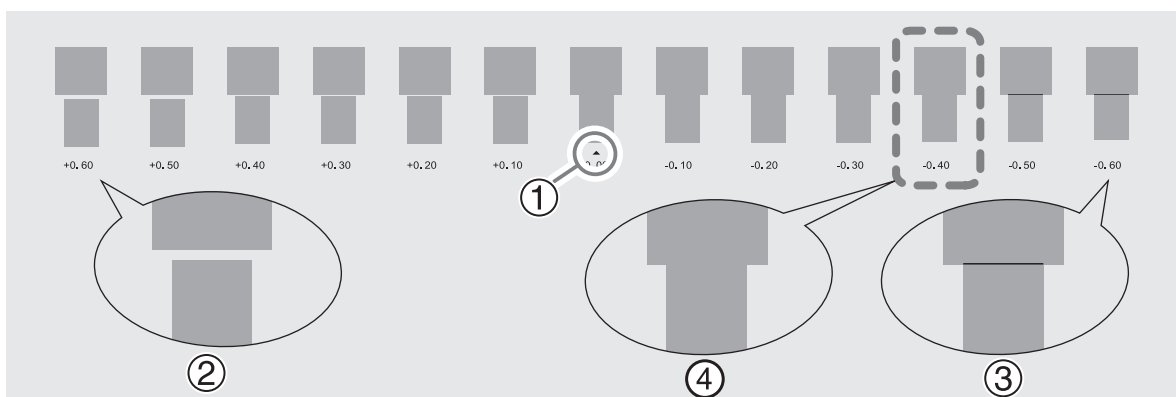
The current correction value ① is that of the figure indicated by "▲." Select the value to make the gap ② and overlap ③ between the upper/lower squares smallest. In the case of the following figure, select "-0.40." (④). When you cannot choose between two sequential numbers, specify a value that is between them.



MEMO

- If the test pattern is difficult to see, tap  or  next to [Media Feed] to move the media to a position where it is easier to see.

- If you want to hold the media to check the test pattern, tap [Execute] next to [Sheet Cutting] to separate the media.

8. Tap [Save].

The entered correction value is saved.

9. Tap [Printing Test]>[Execute].

The test pattern is printed again.

10. Check the test pattern to see whether the correction was successful.

Check that the gap and overlap are the smallest for the figure indicated by "▲" (that is, the current correction value). If the gap and overlap are smaller for another figure, set the correction value again.

11. When you have successfully performed the correction, tap  to go back to the home screen.

Manual Adjustment: Adjusting the Misalignment of the Ink Landing Position (Media Gap Adjustment)

This adjusts the landing position of the ink discharged from the print heads. The landing position varies according to the print head height and the thickness of the media, so we recommend that you make corrections to match the media you are using.

First, print a test pattern, and then determine and enter the correction value. After entering the correction value, print a test pattern again and check the correction results.



This adjustment must be performed in the following cases.

- When using this machine for the first time
- When changing the media to use
- When the print head height was changed

MEMO

The printing test width is approximately 200 mm (7.87 in.). Check that a printing area which can be printed has been secured, then perform the printing test.



Procedure

1. Set up the media.
2. Close the front cover.
3. Tap .
4. Tap [Media Settings]>[Printing Settings]>[Media Gap Adjustment].
5. Select [Detailed Correction (Manual)] and tap [Next].
6. Tap [Printing Test]>[Execute].
Printing of the test pattern starts.
7. Check the printed test pattern, and then tap  or  to change the No. 1 and No. 2 H1 correction values.

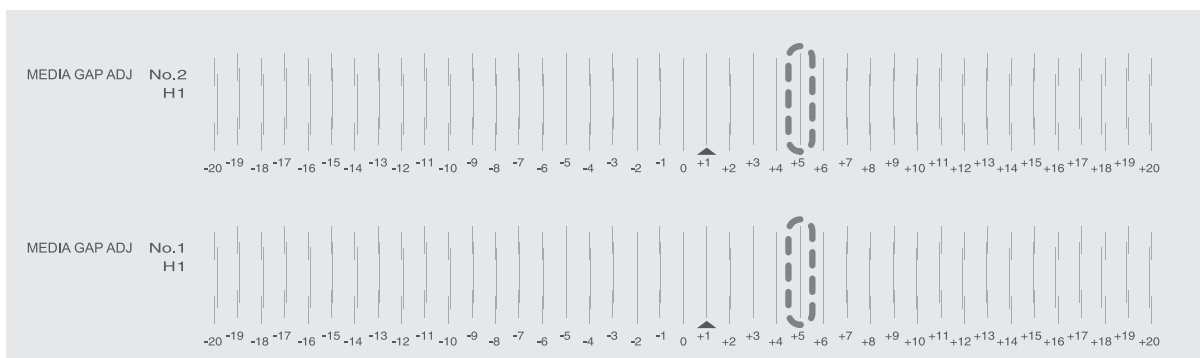
Select the value that gives the least misalignment between the two lines. In the case of the following figure, select "+5" for H1 of No. 1 and No. 2. When you cannot choose between two sequential numbers, select a value that is between them (you can set correction values in units of "0.5").



MEMO

- If the test pattern is difficult to see, tap  or  next to [Media Feed] to move the media to a position where it is easier to see.
- If you want to hold the media to check the test pattern, tap [Execute] next to [Sheet Cutting] to separate the media.

8. Tap [Save].

The entered correction value is saved.

9. Tap [Printing Test]>[Execute].

The test pattern is printed again.

10. Check the test pattern to see whether the correction was successful.

For all the correction values, check that the misalignment is minimized for the two vertical lines indicated by "▲" (that is, the current correction value). If the misalignment is smaller for another set of vertical lines, set the correction value again.

11. When you have successfully performed the correction, tap  to go back to the home screen.

Configuring Settings to Match the Properties of the Media

Changing the Print Head Height

This adjusts the print head height to prevent media that is wrinkled or comes loose from the platen from contacting the print heads.

You can select the print head height from [Low], [Medium], and [High]. Printing quality when the print head height is set to [Medium] or [High] may be coarser or otherwise lower than when set to [Low].

Procedure

1. Set up the media.
2. Tap .
3. Tap [Media Settings]>[Printing Settings]>[Print Head Height].
4. Tap [Change].
The print head carriage moves to a position where they can be operated.
5. Open the front cover.
6. Move the height-adjustment lever to adjust the head height.
When you change the position of the height-adjustment lever, the screen changes and the buzzer sounds at the same time.

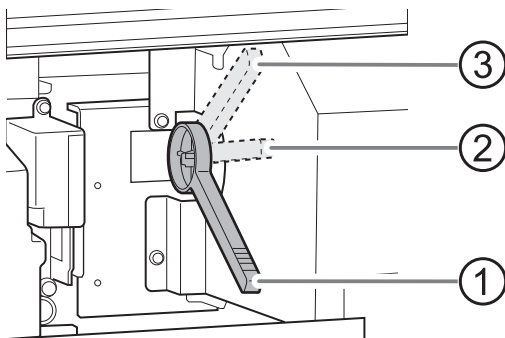

Position	Operation panel display	Description
①	[Low]	Normally set the height-adjustment lever to [Low].
②	[Medium]	For media that is wrinkled or comes loose from the platen during printing, set the height-adjustment lever to [Medium].
③	[High]	If the media still hits the print head even after setting to [Medium], set to [High].

IMPORTANT

The printing quality degrades as the distance between the media and the print heads increases. Do not move the height-adjustment lever to [Medium] or [High] needlessly.

7. Close the front cover.
8. Tap [OK].

The print head carriage moves to their original position.

9. Tap  to return to the home screen.

MEMO

- Default setting: [Low]
- If degradation of printing quality occurs after raising the print head height, refer to the following information and try optimizing the quality.





RELATED LINKS

- [P. 175 Automatically Making Required Adjustments](#)
- [P. 178 Manual Adjustment: Adjusting the Misalignment of the Ink Landing Position \(Media Gap Adjustment\)](#)

Using Hard-to-Dry Media

This setting is used to extend the drying time when the ink dries poorly even if the dryer is used.

Procedure

1. Set up the media.
2. Tap .
3. Tap [Media Settings]>[Other Media Settings]>[Drying Time Per Scan].
4. Tap  or  to change the value.
Larger values cause the media to move more slowly, extending the drying time accordingly.
5. Tap [Save] to confirm your entry.
6. Tap  to return to the home screen.

MEMO

- Default setting: [Off]
- Depending on the RIP software you are using, you can also configure this setting in the RIP software. If you have configured the setting in the RIP software, the printer's setting is ignored.



RELATED LINKS

- [P. 188 Adjusting the Ink-drying Method](#)

Using Media That Wrinkles Easily/Does Not Move Smoothly

The platen uses suction to grip the media and keep it stable. The suction force can be adjusted corresponding to the nature and condition of the media.

Procedure

1. Set up the media.
2. Tap .
3. Tap [Media Settings]>[Other Media Settings]>[Media Suction Force].
4. Tap  or  to change the value.

0 to 100%	When the media is flimsy and cannot move smoothly, such as with thin films, decreasing this value (reducing the suction force) may correct the problem.
Auto	The suction force is automatically adjusted to the optimal level for the media width.

5. Tap [Save] to confirm your entry.
6. Tap  to return to the home screen.

MEMO



- Default setting: [Auto]
- Depending on the RIP software you are using, you can also configure this setting in the RIP software. When you have configured the setting in the RIP software, the machine's setting is ignored.

Using Sticky Media

This setting is used to peel off the media before starting printing when using media that sticks easily to the platen. This setting is effective to prevent media jams.

Note, however, that peeling off the media may cause unstable media feed. Leave this menu item set to **[Disable]** unless you specifically need to change it.

Procedure

1. Set up the media.
2. Tap .
3. Tap **[Media Settings]>[Other Media Settings]>[Media Sticking Prevention]**.
4. Select **[Enable]**.
5. Tap **[Save]** to confirm your entry.
6. Tap  to return to the home screen.

MEMO

- Default setting: **[Disable]**
- Depending on the RIP software you are using, you can also configure this setting in the RIP software. When you have configured the setting in the RIP software, the machine's setting is ignored.

Take-up Unit Settings

Setting the Take-up Unit

Make sure the following settings match the loading method and output method of the actual media. The settings will have to be changed from the defaults when:

- Using weak media
- Taking up the media with an inward curl
- Taking up the media during cutting process in the Print & Cut mode

Procedure

1. Follow the procedure below to configure the take-up unit.

- (1) Tap .
- (2) Tap [Preferences]>[Take-up].
- (3) Tap [Take-up during Cutting].
- (4) Select [Enabled] or [Disabled].

[Enabled]	The media is taken up during cutting while slack is being created. This prevents the media from sticking to the floor. Make sure the media is taken up at least halfway around the paper tube beforehand.
[Disabled]	The media is taken up after all cutting finishes.

MEMO

- Default setting: [Disabled]
- [Enabled] cannot be performed in the following situations:
 - [Blade Adjustment]>[Printing Test]
 - [Print & Cut Position Adjustment]>[Printing Test 1(Misalignment Check)]/[Printing Test 2(Correction Values)]
 - [Crop Cut Position Adjustment]>[Printing Test 1(Misalignment Check)]/[Printing Test 2(Correction Values)]

IMPORTANT

When [Preferences]>[Take-up]>[Enabled] is set, to preserve cut quality, the speed may be limited to the optimum speed for [Cutting Speed] and [Rise Movement Speed] depending on the set media.

[P. 200 Fine-tuning the Cutting Conditions](#)

- (5) Tap [Save].
- (6) Tap [Take-up Method].
- (7) Select [Loose Winding] or [Tension Winding].

[Loose Winding]	The media is taken up with some slack. This is suited to PVC and other such stiff or slippery media.
[Tension Winding]	The media is stretched and taken up. This is suited to tarpaulin and other such weak media and media that does not slip easily. Even if [Tension Winding] is set, if [Enabled] is enabled, the media is taken up while slack is being created.

MEMO

- Default setting: [Loose Winding]

- (8) Tap [Save].
- (9) Tap [Take-up Direction].
- (10) Select [Backward] or [Forward].

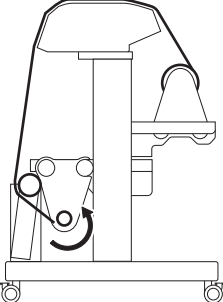
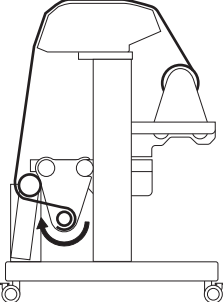
[Forward]	The media is taken up onto the paper tube with the printed surface on the outside. 
[Backward]	The media is taken up onto the paper tube with the printed surface on the inside. 

MEMO

- Default setting: [Forward]

- (11) Tap [Save].
- (12) Tap  to return to the home screen.

Preventing Misaligned Media



Use Middle Pinch Rollers When Pulling Back or Feeding Media

Set the setting that causes the middle pinch rollers to go up automatically during pullback printing or printing and cutting to **[Disable]**. Holding down media that is not straight or comes loose is effective in preventing misalignment during printing and cutting.

[Middle Pinch Auto Raise/Lower] is a function that causes the middle pinch rollers to automatically rise when media is pulled back, performs overprinting and cutting while they are raised. However, if you are performing lengthy printing or using non-resilient media, the media will be skewed or will come loose, which may have an effect on the output quality.

If you set **[Middle Pinch Auto Raise/Lower]** to **[Disable]**, the middle pinch rollers will press down on the media while moving, thus preventing skewing or coming loose. However, because the middle pinch rollers are pressed against the printed surface, it is easier for the rollers to leave a trace on the printed surface. Before pulling back the media, make sure to dry it thoroughly.

Procedure

1. Set up the media.
2. Tap .
3. Tap **[Media Settings]>[Other Media Settings]>[Middle Pinch Auto Raise/Lower]**.
4. Select **[Disable]**.
The middle pinch rollers will lower during media feeding and pullback, pressing down on the media while moving.
5. Tap **[Save]** to confirm your entry.
6. Tap  to return to the home screen.

MEMO

- Default setting: **[Enable]**

RELATED LINKS

- [P. 188 Adjusting the Ink-drying Method](#)

Adjusting the Ink-drying Method

What Is the Media Heating System?

This machine is equipped with a media heating system that warms the media. You use this mainly to improve ink adhesion and to dry the ink. You can adjust the temperature settings to match the type of media and the printing speed.

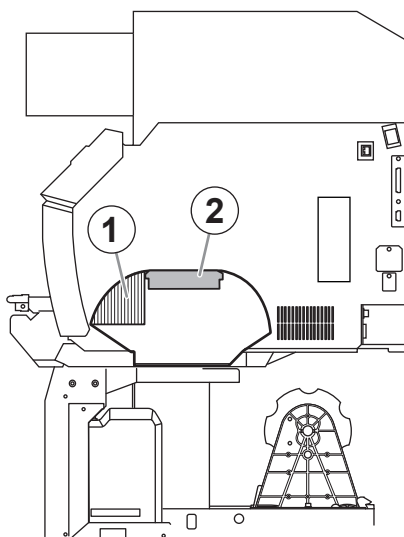

①	[Dryer]	This is used to dry the ink.
②	[Print Heater]	This heater is used mainly to improve ink adhesion.

⚠ WARNING

High Temperature

The platen and dryer become hot. Exercise caution to avoid burns.

⚠ WARNING

Remove any loaded media or switch off the sub power when printing is not being performed.

The continued application of heat at a single location may cause the release of toxic gases from the media or pose a fire hazard.

⚠ WARNING

Never use media that cannot withstand heat.

Doing so may result in fire or the release of toxic gases or may degrade the media.

⚠ WARNING

Never use the platen or dryer for any purpose for which they are not intended, such as to dry clothing.

Doing so may cause overheating, resulting in fire or accident.

IMPORTANT

Use the machine in an environment with an ambient temperature of 20 to 32°C (68 to 89.6°F).

If the machine is used at an ambient temperature lower than 20°C (68°F), then depending on the type or width of the media, wrinkling or temperature-caused unevenness may occur. If this happens, try lowering the temperature of the media heating system by about 2°C (3.6°F). To obtain stable printing results, however, use the machine in an environment with an ambient temperature of 20 to 32°C (68 to 89.6°F).

RELATED LINKS

- [P. 199 Using an Auxiliary Drying Unit \(DU3\)](#)

Setting the Print Heater Temperature

Setting the temperature of the print heater appropriately improves ink adhesion and inhibits smudging. An applicable application is changing the set temperature of registered media.

- With the default settings, the temperature rises to the [Standby Heater Temperature] when the power turns on. On completion of media setup, the temperature rises to the set value.
- Depending on the usage environment, the temperature of the dryer may become higher than the set temperature, but this does not represent a problem.
- Temperature settings are not possible when [Heater Power] accessed from [Media Settings]>[Heater Settings]>[Heater Temperature] is off.

Procedure

1. Set up the media.
2. Tap the following location on the home screen.

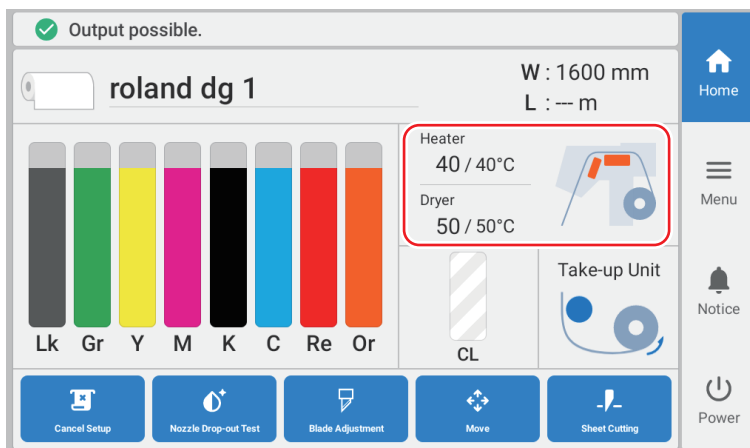

The [Heater Temperature] screen appears.

3. Check that the [Heater Power] is turned on.

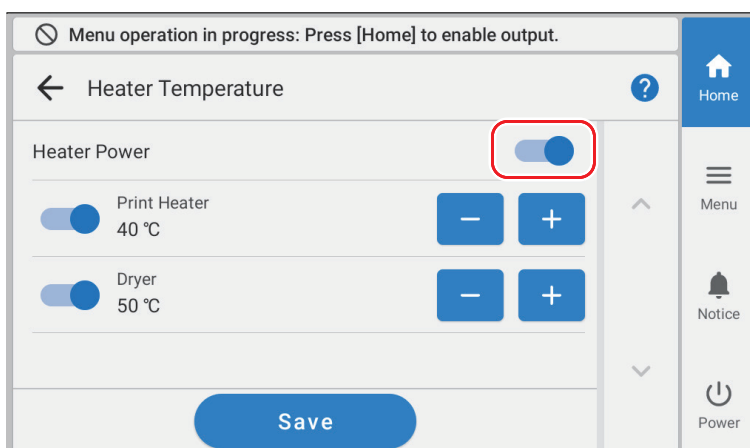

4. Tap **-** or **+** to set the [Print Heater] temperature.

If the ink forms lumps or smudges, raise the temperature. Note, however, that a temperature that is too high may degrade the media or cause it to wrinkle.

5. Tap [Save] to confirm your entry.

6. Tap  to return to the home screen.

MEMO

- Default setting: 40°C (104°F)
- Depending on the RIP software you are using, you can also configure this setting in the RIP software. If you have configured the setting in the RIP software, the RIP software setting is used.

Setting the Dryer Temperature

Setting the temperature of the dryer appropriately makes the ink dry fast. An applicable application is changing the set temperature of registered media.

- With the default settings, the temperature rises to the [Standby Heater Temperature] when the power turns on. On completion of media setup, the temperature rises to the set value.
- Depending on the usage environment, the temperature of the dryer may become higher than the set temperature, but this does not represent a problem.
- Temperature settings are not possible when [Heater Power] accessed from [Media Settings]>[Heater Settings]>[Heater Temperature] is off.

Procedure

1. Set up the media.
2. Tap the following location on the home screen.

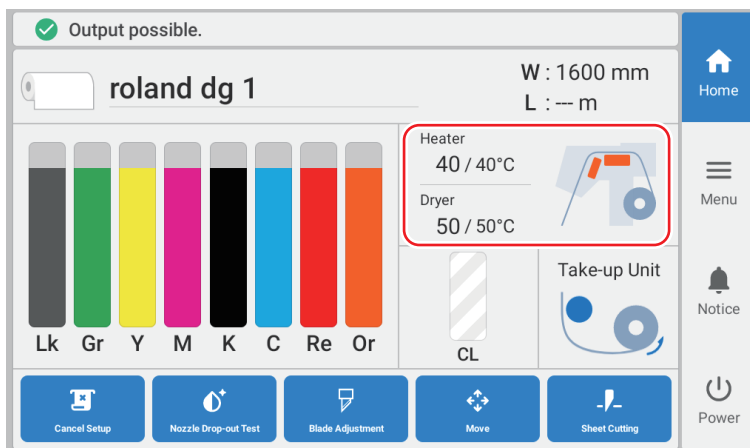

The [Heater Temperature] screen appears.

3. Check that the [Heater Power] is turned on.

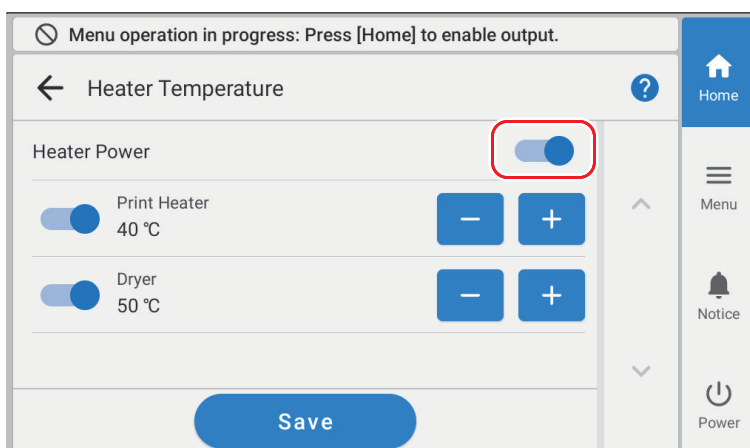

4. Tap **-** or **+** to set the [Dryer] temperature.

When ink drying is poor, set the temperature to a higher value. Note, however, that a temperature that is too high may degrade the media or cause it to wrinkle.

5. Tap [Save] to confirm your entry.

6. Tap  to return to the home screen.

MEMO

- Default setting: 50°C (122°F)
- Depending on the RIP software you are using, you can also configure this setting in the RIP software. If you have configured the setting in the RIP software, the RIP software setting is used.

Hints and Tips for Temperature Control

The optimal temperature for the media heating system varies according to such factors as the type of media and the settings of the RIP software.

Relationship between the quality settings of the RIP software and temperature

If smudging or poor drying occurs even after raising the temperature, try setting the printing quality of the RIP software to higher image quality. Conversely, if you want to use a faster print quality, raise the temperature.

Amount of ink

When you change the amount of ink using the settings for your software RIP, adjusting this may yield better results. If problems such as smudging persist even after raising the temperature, try reducing the amount of ink.





Other points to remember

When recommended settings for temperature, printing quality, and other values are given for your media, use the suggested settings.

Setting the Temperature during Standby

Standby: State in which the main power and the sub power are switched on and the media setup is not complete.

Procedure

1. Tap .
2. Tap [Preferences]>[Standby Heater Temperature].
3. Tap  or  next to [Standby Heater Temperature] to set the temperature.
When this is set to  (off), the media heating system is switched off during standby.
4. Tap [Save] to confirm your entry.
5. Tap  to return to the home screen.



MEMO



- Default setting: 30°C (86°F)

Drying the Trailing Edge of the Printing Area on the Dryer

To dry the ink thoroughly, configure the settings so that the media is fed until the trailing edge of the printed area is put on the dryer after the printing is finished.

Procedure

1. Set up the media.
2. Tap .
3. Tap [Media Settings]>[Heater Settings]>[Dry After Printing].
4. Tap  to turn it on.

[Drying Feed] [(Printing Only)]	This setting applies to output data designed only for printing. This setting is ignored for output data designed for printing and cutting. The margin between the print-end position and the next print-start position is set to a value of 130 mm (5.12 in.) when [Extended Dryer] is set to [Disable] and 310 mm (12.20 in.) when it is set to [Enable].
[Drying Feed] [(Printing amp; Cutting)]	This setting applies to output data designed for printing and cutting. This setting is ignored for output data designed only for printing.
 (On)	Media feed is performed until the trailing edge of the printing area is positioned on the dryer.
 (Off)	Media feed stops when printing ends. This means that the trailing edge of the printing area is not fed to the dryer unless you continue with a subsequent printing operation.

5. Tap  or  to set the [Drying Feed] [(Printing Only)] or [Drying Feed] [(Printing amp; Cutting)] drying time.

MEMO

Drying Time

- The next operation is not started until the set time elapses.
- Tap [Skip] during drying to finish the drying time and start the next operation.
- If the drying time has been set in VersaWorks, priority is given to the VersaWorks setting.
- If [Drying Time] is set to a value other than [0 min] and [Drying Feed] is off, the machine waits for the set time at the print-end position before starting the next operation.

6. Tap [Save] to confirm your entry.
7. Tap  to return to the home screen.

MEMO

Default setting:

- [Drying Feed] [(Printing Only)]: Cleared
- [Drying Feed] [(Printing amp; Cutting)]: Cleared
- [Drying Time] [(Printing Only)]: [0 min.]
- [Drying Time] [(Printing amp; Cutting)]: [0 min.]

Switching Off the Print Heater and Dryer Together

This setting is useful when you want to switch off the media heating system collectively, such as when performing only cutting. Turning off [Heater Power] under [Media Settings]>[Heater Settings]>[Heater Temperature] will make it impossible to set the temperature of the print heater and dryer.

Procedure

1. Set up the media.
2. Tap the following location on the home screen.

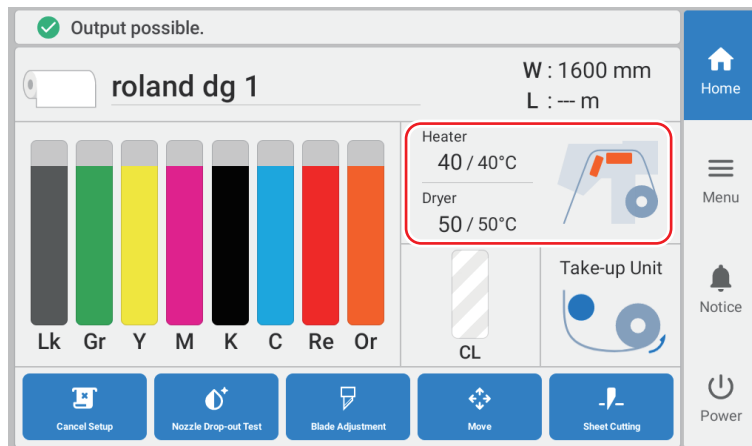

The [Heater Temperature] screen appears.

3. Tap  next to [Heater Power] to turn it off.

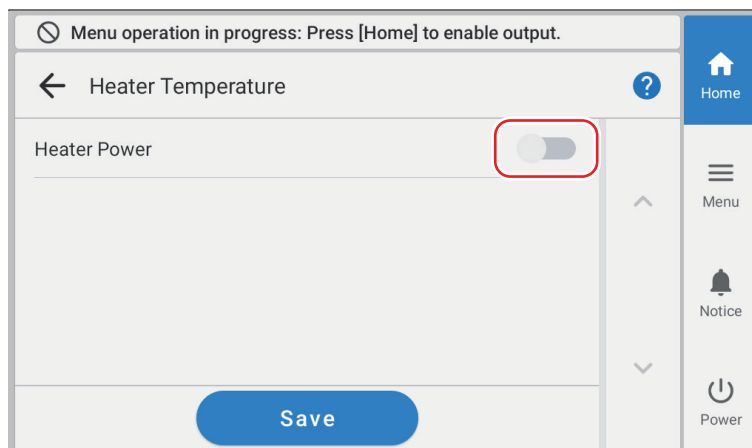

The settings for the print heater and dryer are turned off.

4. Tap [Save] to confirm your entry.
5. Tap  to return to the home screen.

MEMO

- Default setting: Selected



IMPORTANT

When this is set to off, the heater will not turn on even if the heater temperature is set in VersaWorks.

Using an Auxiliary Drying Unit (DU3)

This setting is required when using an auxiliary drying unit (DU3). When [Extended Dryer] is set to [Enable], the temperature is set to the same temperature as the printer's dryer. When [Blower Fan] is set to [Enable], the blower fan turns during printing.

Procedure

1. Set up the media.
2. Tap .
3. When using [Extended Dryer], configure the settings as shown below.
 - (1) Tap [Preferences]>[Extended Dryer].
 - (2) Select [Enable].
 - (3) Tap [Save] to confirm your entry.
4. When using [Blower Fan], configure the settings as shown below.
 - (1) Tap  to go back to the previous screen.
 - (2) Tap [Blower Fan].
 - (3) Select [Enable].
 - (4) Tap [Save] to confirm your entry.
5. Tap  to return to the home screen.

MEMO

- Default setting
 - [Extended Dryer]: [Disable]
 - [Blower Fan]: [Disable]
- For information about the DU3, contact your authorized dealer or visit our website (<https://www.rolanddg.co.jp/>).
- For details on how to use the DU3, refer to its documentation.

RELATED LINKS







- [DU-3 User's Manual](#)

Accurately Adjusting the Cutting Settings

Fine-tuning the Cutting Conditions



You can accurately set items such as the blade force, movement speed, and blade offset to match the nature of the media and the shape to cut. First, perform a cutting test, and then determine and enter the setting values. After entering the setting values, perform a cutting test again and check the results. Repeat the process of performing a cutting test and making the settings several times to find the optimal setting values.

Procedure

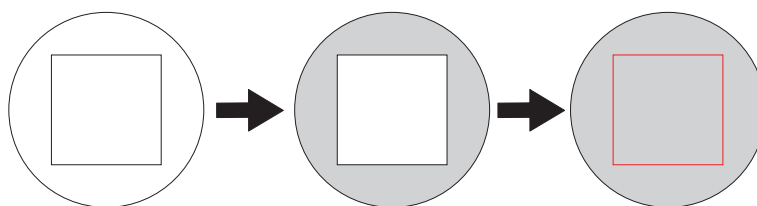
1. Set up the media.
2. Tap  [Blade Adjustment] on the home screen.
3. Tap [Change] next to [Output Start Location].
4. Tap .
The cutting carriage moves to the current base point.
5. Tap , , , or  to move the cutting carriage to the location where you want to carry out the cutting test.
You can freely set the location for the cutting test.
6. Tap [Set Base Point Here].
7. Tap [Execute] next to [Cutting Test].
The test pattern is cut.
8. Check the results of the cutting test.
Check that the two shapes are peeled off separately, a blade trace (red line) remains on the backing paper, and the backing paper is not cut.



Check item	Result	Setting item	Adjustment
Check the shape.	The cut shape is distorted.	[Cutting Speed]	Reduce
Peel off the circle.	The square also peels off.	[Blade Force]	Increase
	Some uncut areas remain.	[Cutting Speed]	Reduce
Peel off the square.	The blade leaves faint traces on the backing paper.	[Blade Force]	No change
	The blade trace is indistinct.		Increase
	The blade trace is too deep and cuts into the backing paper.		Reduce

Check item	Result		Setting item	Adjustment
Check the shape of the square you have peeled off.		The corners are not rounded and do not have "horns."	[Blade Offset]	No change
		The corners are rounded.		Increase
		The corners have "horns."		Reduce

9. Tap  or  to change the settings.

Setting item	Setting details	Default setting
[Blade Force]	Set the force (pressure) of the blade.	50 gf (0.11 lbf)
[Cutting Speed]	Set the speed of cutting.	30 cm/s (11.81 in./s)
[Blade Offset]	Set the blade offset. Enter the listed offset value for the blade. The offset value for the included blade is 0.250 mm (9.8 mil).	0.250 mm (9.84 mil)
[Rise Movement Speed]	Set the blade's up speed during cutting (the speed at which the blade travels when it moves to the next cutting line after cutting one cutting line). If the media comes loose during no-load feed and the blade damages the surface of the media, reduce the speed.	30 cm/s (11.81 in./s)

10. Tap [Save] to confirm your entry.

11. Tap  to return to the home screen.

Adjusting the Amount of Blade Extension

Adjustment when Not Cutting the Backing Paper (Normal Cut)

When you want to perform accurate and fine adjustment of the cutting-in amount, such as when cutting media with thin backing paper, you can obtain good results by adjusting the amount of blade extension (③). Turn the cap portion of the blade holder to adjust the amount of blade extension. Each indicator tick corresponds to 0.1 millimeters, and adjustment for 0.5 millimeters can be made by rotating the cap one full turn.

Note that making the amount of blade extension too small may cause the tip of the blade holder cap to touch the printed surface, soiling and damaging it. It is important to be especially careful about this when you are using media that has poor ink-adhesion properties.

The amount of blade extension (③) is 0 mm (0 in.) (①) at minimum and 2.5 mm (0.09 in.) (②) at maximum.

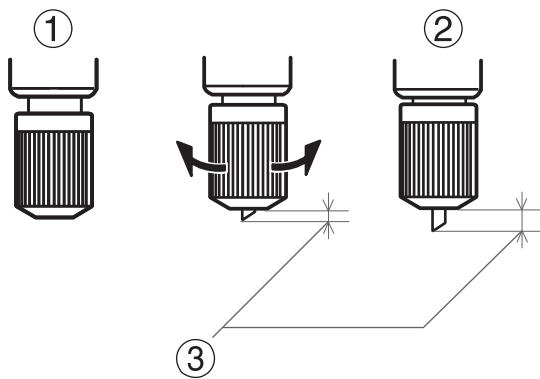

Set the amount of blade extension (①) to an amount that is the sum of the thickness of the media portion (②) and half (④) the thickness of the backing paper (③).

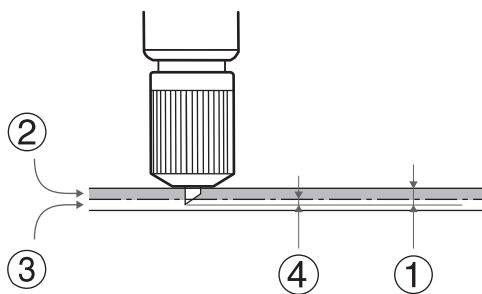

Adjustment when Cutting the Backing Paper (Perforated Cut)

In cases when you want to cut out the printed part, or other cases when you want to cut through the backing paper, use perforated cutting.

IMPORTANT

This function specifies the location to perform perforated cutting in the print data, and performs cutting. This is different from the perforated sheet cutting that cuts to the backing paper at fixed intervals during sheet cutting used when separating the media.

Turn the cap portion of the blade holder to adjust the amount of blade extension. Each indicator tick corresponds to 0.1 mm (3.9 mil), and adjustment for 0.5 mm (19.7 mil) can be made by rotating the cap one full turn.

The amount of blade extension (③) is 0 mm (0 in.) (①) at minimum and 2.5 mm (0.09 in.) (②) at maximum.

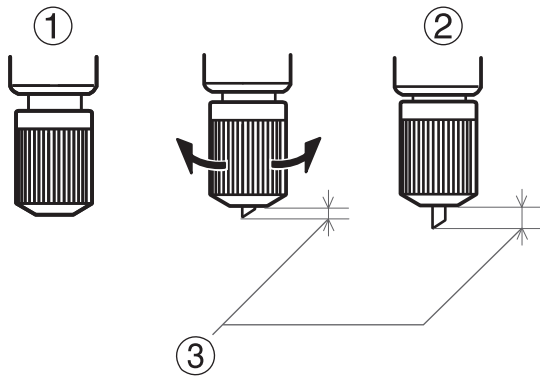

Set the amount of blade extension (③) so that when the cutter pierces the media (④), the blade extends slightly.

For information about the output settings for cutting perforated lines, refer to the documentation for VersaWorks.

<https://downloadcenter.rolanddg.com/VersaWorks7>

IMPORTANT

Pushing the blade out too far will damage the blade and blade protector and hasten their deterioration, so exercise caution.

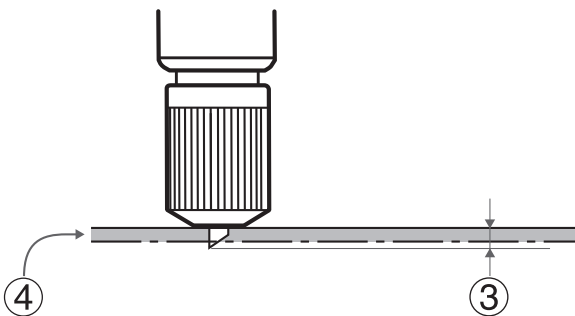



Performing Distance Correction during Cutting

This correction is performed when you want to accurately align the lengths of cut lines when cutting. This setting is applied to both cutting only and printing and cutting.

The movement distance of the media changes subtly depending on the media's thickness. This means that the length of a line when cut may differ from the length setting in the data.

Procedure

1. Set up the media.
2. Tap .
3. Tap [Media Settings]>[Cutting Settings]>[Cutting Distance Correction].
4. Tap  or  to change the correction values.

Setting item	Setting details	Default settings
[Correction Value (Feed)]	(correction value of media feed direction)	0.00%
[Correction Value (Scan)]	Correction value of the print-head carriage movement direction	0.00%

5. Tap [Save] to confirm your entry.
6. Tap  to return to the home screen.



Cutting to Make It Possible to Cut Corners Attractively (Over Cut)

The corners of the border of the cutting line can be cut slightly longer so that the corners can be cut attractively.

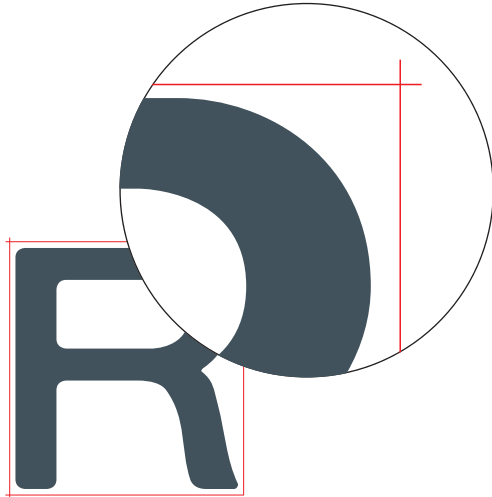
This is effective when using laminated or thick media, or non-resilient media. It also has the effect of making stickers easier to peel off.



Procedure

1. Set up the media.
2. Tap .
3. Tap [Media Settings]>[Cutting Settings]>[Over Cut].
4. Tap [Enable].
5. Tap [Save] to confirm your entry.
6. Tap  to return to the home screen.

MEMO

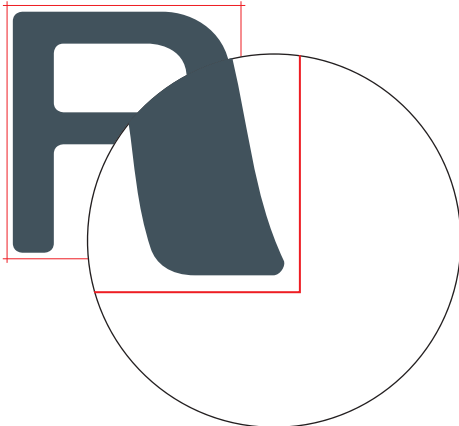

- Default setting: [Disable]
- The cutting start point is not over cut.



Prioritizing the Cutting Settings of This Machine over the RIP Software Settings

This setting is used to prioritize the cutting conditions set on the machine over the RIP software settings. Depending on the RIP software, you can also configure the settings for the cutting conditions, and normally the RIP software settings are given priority.

Procedure

1. Tap .
2. Tap [Preferences]>[Priority for Cutting Settings].
3. Select [Machine Priority].
4. Tap [Save] to confirm your entry.
5. Tap  to return to the home screen.

MEMO

- Default setting: [Software RIP Priority]

Accurately Adjusting the Settings for Printing and Cutting



Correcting the Misalignment of Printing and Cutting

This is a correction method performed when printing followed immediately by cutting yields positioning for printing and cutting that is slightly misaligned.

Print alignment marks, perform detection of the printed marks, and then correct the discrepancy. Subtle misalignment between the printing and cutting positions may occur due to the thickness of the media or the print head height. We recommend that you make corrections to match the media you are using.

1. Adjusting the Misalignment of the Ink Landing Position

Procedure

1. Set up the media.
2. Tap .
3. Tap [Media Settings]>[Printing Settings]>[Media Gap Adjustment].
4. Select [Simple Correction (Auto)] and tap [Next].
5. Tap [Execute].
The test pattern is printed and the media gap is adjusted automatically.
6. Tap [OK] when the completion screen appears.
7. Perform the operations shown below according to the [Result].
 - If [Successful] is displayed on the operation panel, tap  to go back to the home screen.
 - If [Failed] is displayed on the operation panel, manually adjust the media gap.

RELATED LINKS

- [P. 178 Manual Adjustment: Adjusting the Misalignment of the Ink Landing Position \(Media Gap Adjustment\)](#)

2. Correcting the Misalignment of Printing and Cutting

Procedure

1. Tap .
2. Tap [Media Settings]>[Cutting Settings]>[Print & Cut Position Adjustment].
3. Tap [Execute] next to [Printing Test 1(Misalignment Check)].
Printing Test 1 is printed and cut. The test pattern is printed at each edge of the media.

MEMO

If the media is tilted, the positions at the edges will be misaligned. You can also adjust for misalignments due to the media being tilted by printing the test pattern at each edge.

4. Check the result of Printing Test 1.
Check whether the printing position (shaded part) and the cutting position (red line) are aligned. An example of the printing position and the cutting position being misaligned is shown in the following figure.
[F] indicates the feed direction of the media (the feed direction) and [S] indicates the direction of print head carriage movement (the scan direction).

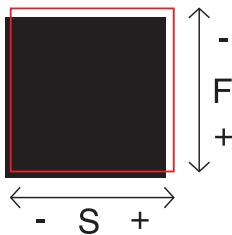

If the printing position and the cutting position are aligned, no corrections are necessary. Proceed to step 10.

If the printing position and the cutting position are not aligned, proceed to the next procedure.

5. Tap [Execute] next to [Printing Test 2(Correction Values)].
Printing Test 2 is printed and cut.
6. Check the correction values from the Printing Test 2 condition.
The point where the cutting line (A) intersects the correction-value scale (B) is the correction value. In the following figure, the correction value is "-0.3."
Check the media feed direction (the feed direction) and the direction of print-head carriage movement (the scan direction).

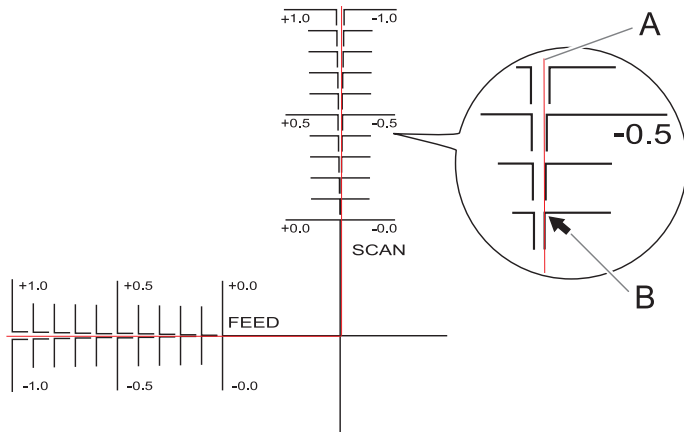

7. Set the correction values in the feed direction of the media (the feed direction) and the direction of print-head carriage movement (the scan direction).
 - (1) Tap **-** or **+** next to [Correction Value (Feed)] to set the correction value in the feed direction of the media (the feed direction).
 - (2) Tap **-** or **+** next to [Correction Value (Scan)] to set the correction value in the direction of print head carriage movement (the scan direction).

8. Tap [Save].
The correction values are saved.

9. Tap [Execute] next to [Printing Test 1(Misalignment Check)].
Printing Test 1 is printed and cut. If the printing and cutting lines are aligned, adjustment is complete. If further adjustment is needed, tap **-** or **+** next to [Correction Value (Feed)] and [Correction Value (Scan)] to fine-tune the printing and cutting position, and then [Save] the values.

MEMO

Default settings

- [Correction Value (Feed)] (correction value of the media feed direction): 0.00 mm
- [Correction Value (Scan)] (correction value of the print-head carriage movement direction): 0.00 mm

10. Tap  to return to the home screen.

Correcting the Misalignment of the Printing and Cutting Positions during Cutting

This method pauses a cutting operation to correct the misalignment of the cutting positions (A) when this misalignment is found during cutting after printing. The correction values set here are applied to the media settings currently set up.



If the printing and cutting positions are misaligned, normally adjust the positions while checking a test pattern.

Procedure

1. During cutting, tap [Pause].
The cutting operation is paused.
2. Tap .
3. Tap [Media Settings]>[Cutting Settings]>[Print & Cut Position Adjustment].
4. Determine the correction value for the cutting position.

MEMO

To decide a correction value

In the following figure, move the solid line (A), representing the current cutting position, to the dashed line (B).

[F] indicates the feed direction of the media (the feed direction) and [S] indicates the direction of print head carriage movement (the scan direction).

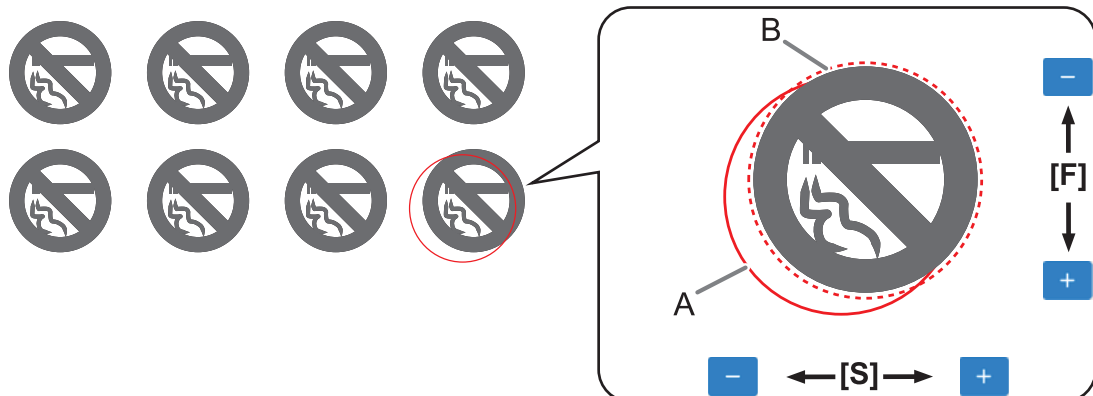

- Media feed direction misaligned in the positive direction

- Move the cutting position in the negative direction.
- Print head carriage movement direction (the scan direction) is misaligned in the negative direction.
- Move the cutting position in the positive direction.

5. Set the correction values in the feed direction of the media (the feed direction) and the direction of print-head carriage movement (the scan direction).

(1) Tap **-** or **+** next to [Correction Value (Feed)] to set the correction value in the feed direction of the media (the feed direction).

(2) Tap **-** or **+** next to [Correction Value (Scan)] to set the correction value in the direction of print head carriage movement (the scan direction).

6. Tap [Save] to confirm your entry.

7. Tap  to return to the home screen.

8. Tap [Resume] to restart the cutting operation.

Tap [Cancel Output] to cancel the cutting operation.

MEMO

Default settings

- [Correction Value (Feed)] (correction value of the media feed direction): 0.00 mm
- [Correction Value (Scan)] (correction value of the print-head carriage movement direction): 0.00 mm

RELATED LINKS

- [P. 207 Correcting the Misalignment of Printing and Cutting](#)

Accurately Adjusting the Settings for Cutting with Crop Marks



Correcting the Misalignment of Printing and Cutting with Crop Marks (Concurrent Test for Printing and Cutting with Crop Marks)

Depending on the composition of the media, the positioning of printing and cutting may be misaligned even when you are using crop marks. Make corrections for misaligned printing and cutting for the media you are using.

In cutting with crop marks, the media is removed after printing and then cut. However, with this method, you can make corrections of printing and cutting positions at the same time without removing the media.

1. Adjusting the Misalignment of the Ink Landing Position

Procedure

1. Set up the media.
2. Tap .
3. Tap [Media Settings]>[Printing Settings]>[Media Gap Adjustment].
4. Select [Simple Correction (Auto)] and tap [Next].
5. Tap [Execute].
The test pattern is printed and the media gap is adjusted automatically.
6. Tap [OK] when the completion screen appears.
7. Perform the operations shown below according to the [Result].
 - If [Successful] is displayed on the operation panel, tap  to go back to the home screen.
 - If [Failed] is displayed on the operation panel, manually adjust the media gap.



RELATED LINKS

- [P. 178 Manual Adjustment: Adjusting the Misalignment of the Ink Landing Position \(Media Gap Adjustment\)](#)

2. Correct the misalignment of printing and cutting with crop marks at the same time.

Use the following procedure to print the crop marks and cut the media, checking for misalignment in the positions. In this section, the crop marks are printed simply, and then the crop marks are read and a cutting test is performed without removing the media. To simulate the actual process—printing crop marks, removing the media, and then performing post-processing such as laminating—before loading the media and checking for cutting position misalignment, turn on **[Separate Test for Printing/Cutting with Crop Marks]**. For more information, refer to [Correcting the Misalignment of Printing and Cutting with Crop Marks \(Separate Test for Printing and Cutting with Crop Marks\)\(P. 215\)](#).

Procedure

1. Tap .
2. Tap **[Media Settings]>[Cutting Settings]>[Crop Cut Position Adjustment]**.
3. Tap  next to **[Separate Test for Printing/Cutting with Crop Marks]** to turn it off.
4. Tap **[Execute]** next to **[Printing Test 1(Misalignment Check)]**.
Printing Test 1 is printed and cut. One test pattern is printed on the media.

IMPORTANT

Printing (crop marks) may not be readable with transparent media, silver or other light-reflective media, or black or other dark-colored media, which may prevent cutting from being performed. Try the following if **[Crop Mark Detection Error]** is displayed.

- [Are you using transparent media?\(P. 368\)](#)
- [Are you using media that is likely to reflect light or has deep colors?\(P. 368\)](#)

5. Check Printing Test 1.

Check whether the printing position (shaded part) and the cutting position (red line) are aligned. An example of the printing position and the cutting position being misaligned is shown in the following figure.

[F] indicates the feed direction of the media (the feed direction) and [S] indicates the direction of print head carriage movement (the scan direction).

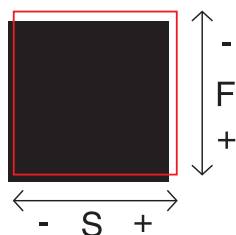

If the printing position and the cutting position are aligned, no corrections are necessary. Proceed to step 11.

If the printing position and the cutting position are not aligned, proceed to the next procedure.

6. Tap **[Execute]** next to **[Printing Test 2(Correction Values)]**.
Printing Test 2 is printed and cut.
7. Check the correction values from the Printing Test 2 condition.

The point where the cutting line (A) intersects the correction-value scale (B) is the correction value. In the following figure, the correction value is "-0.3."

Check the media feed direction (the feed direction) and the direction of print-head carriage movement (the scan direction).

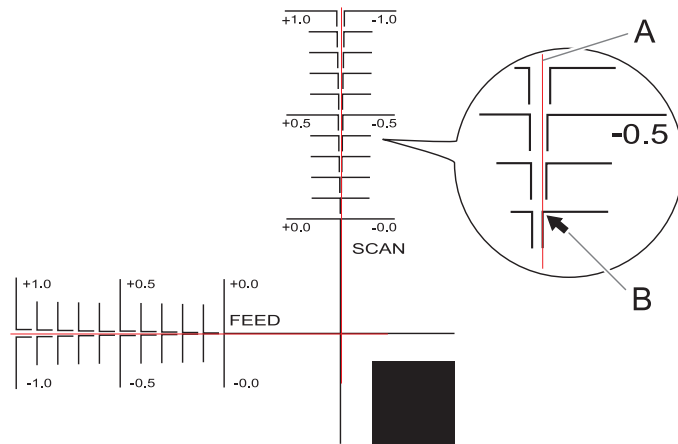

8. Set the correction values in the feed direction of the media (the feed direction) and the direction of print-head carriage movement (the scan direction).
 - (1) Tap **-** or **+** next to [Correction Value (Feed)] to set the correction value in the feed direction of the media (the feed direction).
 - (2) Tap **-** or **+** next to [Correction Value (Scan)] to set the correction value in the direction of print head carriage movement (the scan direction).

9. Tap [Save].
The correction values are saved.

10. Tap [Execute] next to [Printing Test 1(Misalignment Check)].
Printing Test 1 is printed and cut. If the printing and cutting lines are aligned, adjustment is complete. If further adjustment is needed, tap **-** or **+** next to [Correction Value (Feed)] and [Correction Value (Scan)] to fine-tune the printing and cutting position, and then [Save] the values.

MEMO

- Default setting
 [Correction Value (Feed)] (correction value of the media feed direction): 0.00 mm (0.00 in.)
 [Correction Value (Scan)] (correction value of the print-head carriage movement direction): 0.00 mm (0.00 in.)
- Depending on the changes in the condition of media caused by laminating and the loading position of the media before cutting, the positioning of cutting may be misaligned. In such cases, correct the misalignment of printing and cutting with crop marks.

11. Tap  to return to the home screen.

RELATED LINKS

- [P. 215 Correcting the Misalignment of Printing and Cutting with Crop Marks \(Separate Test for Printing and Cutting with Crop Marks\)](#)

Correcting the Misalignment of Printing and Cutting with Crop Marks (Separate Test for Printing and Cutting with Crop Marks)

Due to changes in the thickness of media caused by laminating and misalignment of the loading position of the media before and after cutting, the positioning of printing and cutting may be misaligned even when you are using crop marks. Make corrections for misaligned printing and cutting for the media you are using and its condition.



In this test, so as to create the same conditions as the actual operation, print only the crop marks, remove the media, load the media again, and then cut the media.

MEMO

- The required pre-print margin for [Separate Test for Printing/Cutting with Crop Marks] is at least 75 mm (2.96 in.), and the required post-print margin is at least 130 mm (5.12 in.).

1. Adjusting the Misalignment of the Ink Landing Position

Procedure





1. Set up the media.
2. Tap .
3. Tap [Media Settings]>[Printing Settings]>[Media Gap Adjustment].
4. Select [Simple Correction (Auto)] and tap [Next].
5. Tap [Execute].
The test pattern is printed and the media gap is adjusted automatically.
6. Tap [OK] when the completion screen appears.
7. Perform the operations shown below according to the [Result].
 - If [Successful] is displayed on the operation panel, tap  to go back to the home screen.
 - If [Failed] is displayed on the operation panel, manually adjust the media gap.

RELATED LINKS

- [P. 178 Manual Adjustment: Adjusting the Misalignment of the Ink Landing Position \(Media Gap Adjustment\)](#)

2. Print only the crop marks.

Procedure







1. Tap .
2. Tap [Media Settings]>[Cutting Settings]>[Crop Cut Position Adjustment].
3. Tap  next to [Separate Test for Printing/Cutting with Crop Marks] to turn it on.
4. Tap [Execute] next to [Printing Test].
Printing of the test pattern starts.
The crop marks are printed. When printing is finished, you will return to the original screen.
5. Remove any media.
Use the following procedure to separate the media.
 - (1) Close the front cover.
 - (2) Tap [Change] next to [Output Start Location].
 - (3) Tap  to feed the media until there is a margin of 130 mm (5.12 in.) or more after the printed crop marks.
 - (4) Tap  to go back to the previous screen.
 - (5) Tap [Execute] next to [Sheet Cutting].
 - (6) Tap [Yes] on the confirmation screen.
6. Complete operations before cutting output for normal cutting with crop marks, such as laminating.

RELATED LINKS

- [P. 122 Separating the Media](#)

3. Perform a cutting test.

Procedure

1. Set up the media for which operations before cutting output, such as lamination, is complete.
2. Tap .
3. Tap [Media Settings]>[Cutting Settings]>[Crop Cut Position Adjustment].
4. Tap  next to [Separate Test for Printing/Cutting with Crop Marks] to turn it on.
5. Tap [Execute] next to [Cutting Test].
The [Move the blade over a crop mark.] screen appears.
6. Tap , , , or  to move the center of the blade over the crop marks to use in the cutting test.

The center of the blade should only be over the crop marks, and does not need to be aligned with the center of the crop marks.

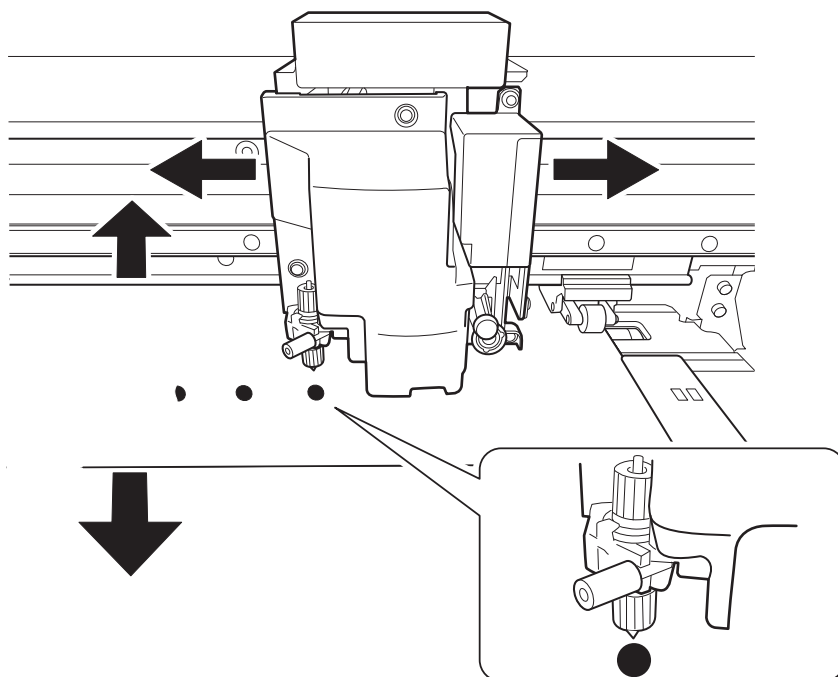

7. Tap [Execute].
The cutting test starts.

IMPORTANT

Printing (crop marks) may not be readable with transparent media, silver or other light-reflective media, or black or other dark-colored media, which may prevent cutting from being performed. Try the following if [Crop Mark Detection Error] is displayed.

- Are you using transparent media?(P. 368)
- Are you using media that is likely to reflect light or has deep colors?(P. 368)

4. Setting the Correction Values

Procedure

1. View the results of the cutting test to determine the correction values.

Check whether the crop mark (shaded part) and the cutting position (red line) are aligned. An example of the crop mark and the cutting position being misaligned is shown in the following figure.

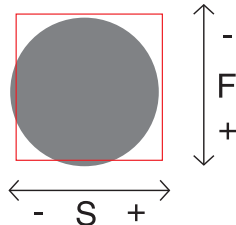

- If the test printed crop marks are inside the cutting line, correction is not necessary. Proceed to step 5.
- If the test printed crop marks are extending beyond the cutting line, correction is necessary.

[F] indicates the feed direction of the media (the feed direction) and [S] indicates the direction of print-head carriage movement (the scan direction). ("F," "S," "+," "-", and the arrows are not displayed on the actual test pattern.)

MEMO

Determine the values so as to correct the misalignment of the cutting position. In the case of the above figure, feed direction [F] is misaligned in a negative direction and scan direction [S] in a positive direction. Therefore, set the correction values for the feed direction [F] to positive values and the scan direction [S] to negative values. Measure the actual misalignment amount when determining the value.

2. Set the correction values in the feed direction of the media (the feed direction) and the direction of print-head carriage movement (the scan direction).
 - (1) Tap **-** or **+** next to [Correction Value (Feed)] to set the correction value in the feed direction of the media (the feed direction).
 - (2) Tap **-** or **+** next to [Correction Value (Scan)] to set the correction value in the direction of print head carriage movement (the scan direction).
3. Tap [Save].
4. Perform steps 5 to 7 of 3. **Perform a cutting test.(P. 217)** again to check whether the correction was successful.
 - If the test printed crop marks are inside the cutting line, correction is complete.
 - If the test printed crop marks are extending beyond the cutting line, redo the correction.
5. Tap  to return to the home screen.

MEMO

- Default settings
 - [Correction Value (Feed)] (correction value of the media feed direction): 0.00 mm
 - [Correction Value (Scan)] (correction value of the print-head carriage movement direction): 0.00 mm

- You can also make corrections of printing and cutting positions at the same time without removing the media.

RELATED LINKS

- [P. 212 Correcting the Misalignment of Printing and Cutting with Crop Marks \(Concurrent Test for Printing and Cutting with Crop Marks\)](#)

Correcting the Reading Sensor

Depending on the characteristics of the media, such as reflectivity and colors, the machine may not be able to read the media width. In such cases, correct the sensor for reading the media.

Procedure

1. Set up the media.
2. Tap .
3. Tap [Media Settings]>[Other Media Settings]>[Multi Sensor Adjustment].
4. Tap [Execute].
5. Perform the operations shown below according to the [Adjustment Result].
 - If [Successful] is displayed on the operation panel, proceed to the next procedure.
 - If [Failed] is displayed on the operation panel, the following causes are possible, so take countermeasures and redo the correction.

Cause	Countermeasures
The lighting in the room where the printer is installed or vicinity of the printer is too bright.	Adjust the lighting in the room.
Correction failed for some reason.	Redo the correction.
Crop marks cannot be recognized due to the characteristics (reflectivity and colors) of the media.	To cut with crop marks, try the following. <ul style="list-style-type: none"> • Are you using media that is likely to reflect light or has deep colors?(P. 368) • Are you using transparent media?(P. 368)
There is ink on the multi sensor because, for example, the media strikes it immediately after printing.	Contact your authorized dealer.

6. Tap  to return to the home screen.

Optimizing Work Efficiency

Batch Settings for Output	222
Step 1: Configuring [Batch Media Settings]	222
Step 2: Setting the Heater Temperature.....	223
Step 3: Changing the Print Head Height	224
Step 4: Setting the Media Suction Force.....	226
Step 5: Configuring Media Sticking Prevention Settings.....	227
Step 6: Use Middle Pinch Rollers When Pulling Back or Feeding Media	228
Step 7: Adjusting the Output-start Location	229
Step 8: Performing a Printing Test.....	231
Step 9: Performing Feed Correction (Reducing Horizontal Stripes)	233
Step 10: Adjusting the Misalignment of the Ink Landing Position.....	235
Step 11: Configuring the Settings to Dry the Trailing Edge of the Printing Area	237
Step 12: Setting the Ink Drying Time.....	238
Step 13: Fine-tuning the Cutting Conditions	239
Step 14: Correcting the Reading Sensor	241
Step 15: Correcting the Misalignment of Printing and Cutting	242
Step 16: Correcting the Misalignment of Printing and Cutting with Crop Marks (Concurrent Test for Printing and Cutting with Crop Marks)	244
Step 17: Correcting the Misalignment of Printing and Cutting with Crop Marks (Separate Test for Printing and Cutting with Crop Marks)	246
Step 18: Cutting to Make It Possible to Cut Corners Attractively (Over Cut)	250
Step 19: Setting the Printing Movement Range.....	251
Managing the Media Settings.....	252
Changing the Media Settings	252
Checking the Registered Media Settings.....	254
Changing the Media Name	256
Duplicating Media Settings.....	257
Duplicating Media Settings for Cutting.....	258
Deleting Media Settings	259
Adjusting the Output-start Location.....	260
Setting the Base Point	260
Reducing Output Time	262
Speeding Up Output for Narrow Media.....	262
Printing with Crop Marks	263
Managing VersaWorks Jobs	264
Outputting a Job	264
Displaying the [Printing Log].....	265
Other Useful Functions	266
Performing Printing Tests Arranged Horizontally	266
Changing the Operation Panel Color Theme	267
Displaying the 2D Code for Viewing the Manual on the Operation Panel	268
Displaying the Roland DG Connect 2D Code on the Operation Panel.....	269

Batch Settings for Output

This section explains how to change media settings as a batch during setup.

To ensure the optimal output according to the media size and type, you can configure various settings on this machine. However, it is hard work to configure these settings one at a time. Use [Batch Media Settings] to configure the absolute minimum of necessary items as a batch.

Note that you can set all the items set here individually as well.

To cancel the [Batch Media Settings] at any time, tap  to return to the home screen.

Step 1: Configuring [Batch Media Settings]

MEMO

For these batch media settings, a printing test is performed for adjustment. Load media which can secure the printing area for the printing test. The printing test width is the following.

- Media gap adjustment: Approx. 200 mm (7.87 in.)
- Feed correction: Approx. 375 mm (14.76 in.)

Procedure

1. Set up the media.
2. Tap .
3. Tap [Media Settings]>[Batch Media Settings].

Step 2: Setting the Heater Temperature

The print heater and dryer temperatures can be set as needed.

Setting the temperature of the print heater appropriately improves ink adhesion and inhibits smudging.

Setting the temperature of the dryer appropriately also makes the ink dry fast.

- With the default settings, the temperature rises to the [Standby Heater Temperature] when the power turns on. On completion of media setup, the temperature rises to the set value.
- Depending on the usage environment, the temperature of the dryer may become higher than the set temperature, but this does not represent a problem.

Procedure

1. Check that the [Heater Power] is turned on.

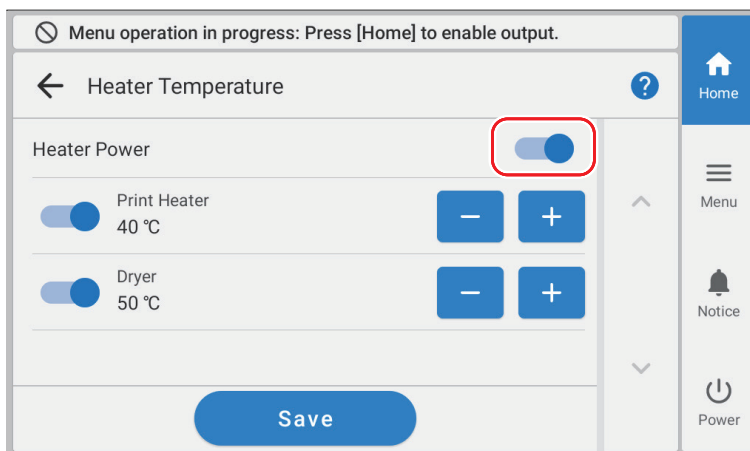

2. Tap **-** or **+** to set the [Print Heater] or [Dryer] temperature.

[Print Heater]: If the ink forms lumps or smudges, raise the temperature. Note, however, that a temperature that is too high may degrade the media or cause it to wrinkle.

[Dryer]: When ink drying is poor, set the temperature to a higher value. Note, however, that a temperature that is too high may degrade the media or cause it to wrinkle.

3. Tap [Save and Proceed].

MEMO

- Default setting:
 - [Print Heater]: 40°C (104°F)
 - [Dryer]: 50°C (122°F)
- Depending on the RIP software you are using, you can also configure this setting in the RIP software. If you have configured the setting in the RIP software, the RIP software setting is used.

Step 3: Changing the Print Head Height

This adjusts the print head height to prevent media that is wrinkled or comes loose from the platen from contacting the print heads.

You can select the print head height from [Low], [Medium], and [High]. Printing quality when the print head height is set to [Medium] or [High] may be coarser or otherwise lower than when set to [Low].

Procedure

1. Tap [Change].

The print head carriage moves to a position where they can be operated.

2. Open the front cover.

3. Move the height-adjustment lever to adjust the head height.

When you change the position of the height-adjustment lever, the screen changes and the buzzer sounds at the same time.

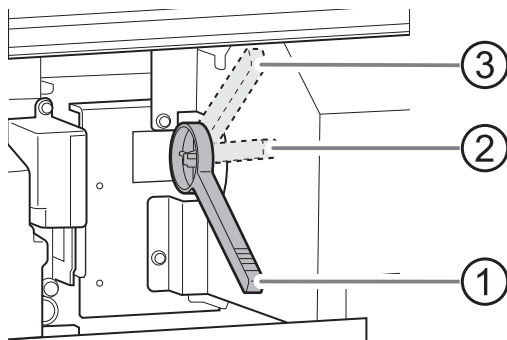

Position	Operation panel display	Description
①	[Low]	Normally set the height-adjustment lever to [Low].
②	[Medium]	For media that is wrinkled or comes loose from the platen during printing, set the height-adjustment lever to [Medium].
③	[High]	For media that is wrinkled or comes loose from the platen during printing even when the height-adjustment lever is set to [Medium], set the lever to [High].

IMPORTANT

The printing quality degrades as the distance between the media and the print heads increases. Do not move the height-adjustment lever to [Medium] or [High] needlessly.

4. Close the front cover.

5. Tap [OK].

The print head carriage moves to their original position.

6. Tap [Next].

MEMO

- Default setting: [Low]

- If degradation of printing quality occurs after raising the print head height, refer to the following information and try optimizing the quality.

RELATED LINKS

- [P. 175 Automatically Making Required Adjustments](#)
- [P. 178 Manual Adjustment: Adjusting the Misalignment of the Ink Landing Position \(Media Gap Adjustment\)](#)

Step 4: Setting the Media Suction Force

The platen uses suction to grip the media and keep it stable. The suction force can be adjusted corresponding to the nature and condition of the media.

Procedure

1. Tap **-** or **+** to change the value.

0 to 100%	When the media is flimsy and cannot move smoothly, such as with thin films, decreasing this value (reducing the suction force) may correct the problem.
Auto	The suction force is automatically adjusted to the optimal level for the media width.

2. Tap [Save and Proceed].

MEMO

- Default setting: [Auto]
- Depending on the RIP software you are using, you can also configure this setting in the RIP software. When you have configured the setting in the RIP software, the machine's setting is ignored.

Step 5: Configuring Media Sticking Prevention Settings

This setting is used to peel off the media before starting printing when using media that sticks easily to the platen. This setting is effective to prevent media jams.

Note, however, that peeling off the media may cause unstable media feed. Leave this menu item set to **[Disable]** unless you specifically need to change it.

Procedure

1. Select **[Enable]**.
2. Tap **[Save and Proceed]**.

MEMO

- Default setting: **[Disable]**
- Depending on the RIP software you are using, you can also configure this setting in the RIP software. When you have configured the setting in the RIP software, the machine's setting is ignored.

Step 6: Use Middle Pinch Rollers When Pulling Back or Feeding Media

Set the setting that causes the middle pinch rollers to go up automatically during pullback printing or printing and cutting to **[Disable]**. Holding down media that is not straight or comes loose is effective in preventing misalignment during printing and cutting.

[Middle Pinch Auto Raise/Lower] is a function that causes the middle pinch rollers to automatically rise when media is pulled back, performs overprinting and cutting while they are raised. However, if you are performing lengthy printing or using non-resilient media, the media will be skewed or will come loose, which may have an effect on the output quality.

If you set **[Middle Pinch Auto Raise/Lower]** to **[Disable]**, the middle pinch rollers will press down on the media while moving, thus preventing skewing or coming loose. However, because the middle pinch rollers are pressed against the printed surface, it is easier for the rollers to leave a trace on the printed surface. Before pulling back the media, make sure to dry it thoroughly.

Procedure

1. Select **[Disable]**.

The middle pinch rollers will lower during media feeding and pullback, pressing down on the media while moving.

2. Tap **[Save and Proceed]**.

MEMO

- Default setting: **[Enable]**

Step 7: Adjusting the Output-start Location

Set the base point to determine the printing area on the set up media.

The base point (④) indicates the right edge of the printing area (①). (②: Media feed direction, ③: print-head carriage movement direction) You can print without setting the base point, but setting the printing area enables you to use media without being wasteful and also to print on the targeted location.

Make this setting for each individual page. When the printing of one page finishes, the base point returns to its default value.

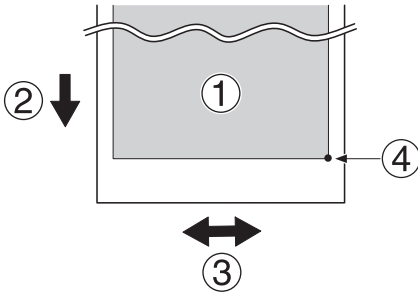

MEMO

- Note that the left and right positions are not restored to their defaults for test patterns.





Procedure

1. Tap [Output Start Location]>[Change].

The movement screen appears.

2. Tap .

The cutting carriage moves to the current base point.

3. Tap , ,  or  to move the center of the blade to the position that you want to set as the base point.

Tap  or  to move the media. Tap  or  to move the cutting carriage.

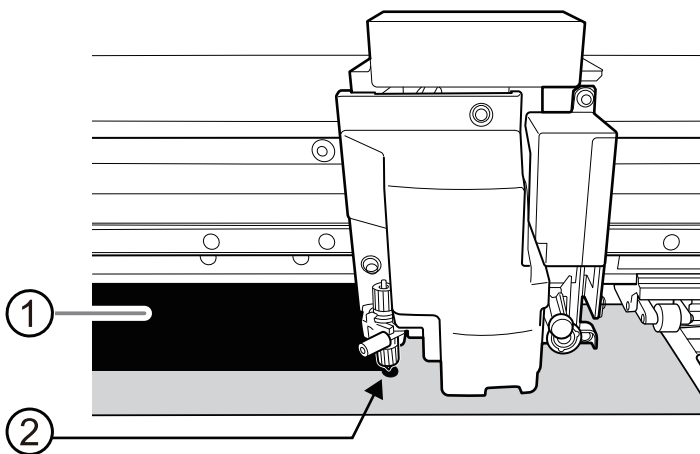

- ①: Printing area
- ②: Base point (right edge of the printing area)

4. Once the position has been decided, tap [Set Base Point Here] to confirm it.

Step 8: Performing a Printing Test

Before you carry out actual printing, perform a printing test to ensure no dot drop-out or dot displacement occurs. If dot drop-out or dot displacement occurs, perform cleaning of the print heads (normal cleaning).

MEMO

When performing printing tests successively, you can select **[Feed]** (vertical printing) or **[Scan]** (horizontal printing) as the printing position for the second and later tests in comparison to the first test.

[P. 266 Performing Printing Tests Arranged Horizontally](#)

Procedure

1. Tap **[Printing Test]>[Execute]**.

Printing of the test pattern starts.

2. Check whether there is dot drop-out or dot displacement in the test pattern.

Missing blocks indicate dot drop-out. Collapsed or inclined blocks indicate dot displacement.

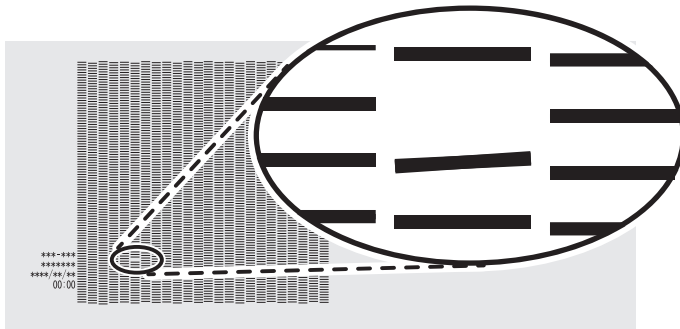

3. If you have opened the front cover, close it.

If dot drop-out or dot displacement is present in the printing test, follow the procedure below to perform normal cleaning.

If there is no dot drop-out or dot displacement, proceed to Step 4.

- (1) Tap **[Cleaning]>[Normal Cleaning]**.

The screen shown below appears.

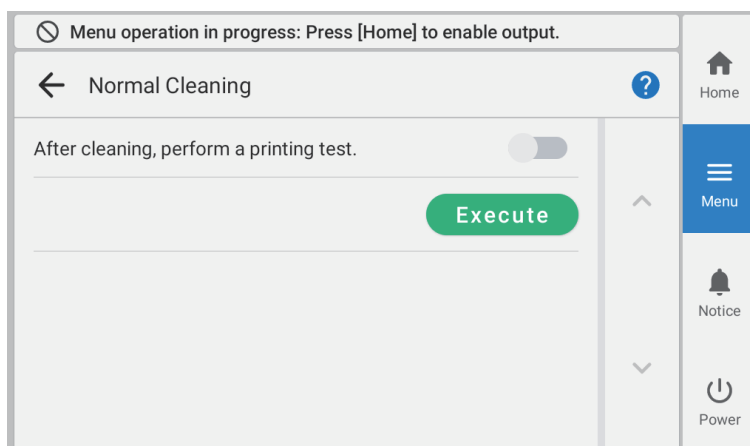

MEMO

If the media has already been set up, the [After cleaning, perform a printing test.] menu appears on the [Normal Cleaning] screen. When this setting is turned on, a printing test is performed after cleaning.

(2) Tap [Execute].

Cleaning will start. The details of the operation in progress and the (approximate) remaining time of that work are displayed in the status bar at the top of the screen. When the work is finished, the status bar returns to its original display.

(3) Tap ← twice.

(4) Tap [Printing Test]>[Execute].

(5) Check to make sure the dot drop-out or dot displacement has been corrected.

If the problem persists, try performing normal cleaning again. If the printer has been used for a long period, dot drop-outs may not be fixed even after performing normal cleaning two or three times. In such cases, refer to [When Normal Cleaning Is Not Effective\(P. 320\)](#).

If there is no dot drop-out or dot displacement, proceed to Step 4.

4. Tap [Next].

Step 9: Performing Feed Correction (Reducing Horizontal Stripes)

Perform corrections to make the band-shaped "stripes" on the printed surface less noticeable.

The band-shaped "stripes" are called "horizontal bands" or "banding." Horizontal bands are caused by the subtle changes in the movement distance that occur when feeding the media depending on the media's thickness and the temperature of the front heater. We recommend that you make corrections to match the media you are using and the set temperature of the front heater.

First, print a test pattern, and then determine and enter the correction value. After entering the correction value, print a test pattern again and check the correction results. Repeat the process of printing a test pattern and entering a correction value several times to find the optimal correction value.

Procedure

1. Tap [Printing Test]>[Execute].

Printing of the test pattern starts.

2. Check the printed test pattern, and then tap **-** or **+** to change the correction value.

The current correction value ① is that of the figure indicated by "▲." Select the value to make the gap ② and overlap ③ between the upper/lower squares smallest. In the case of the following figure, select "-0.40." (④). When you cannot choose between two sequential numbers, specify a value that is between them.

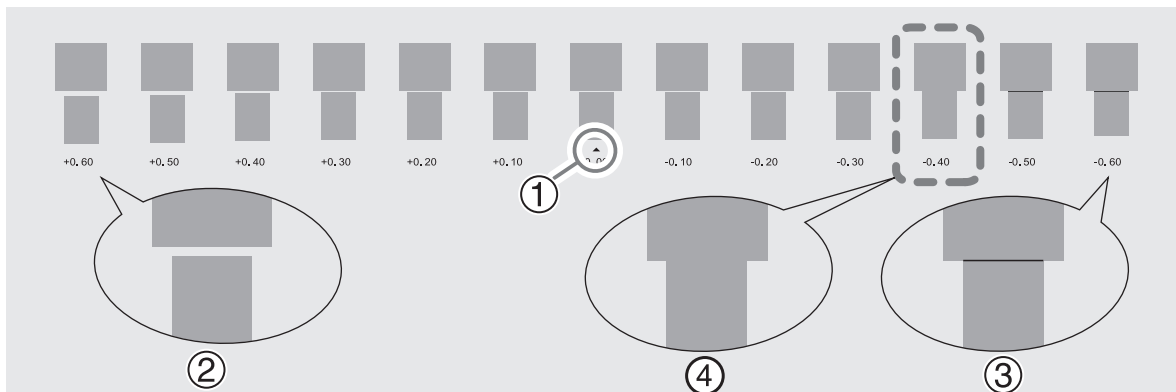

MEMO

- If the test pattern is difficult to see, tap **^** or **v** next to [Media Feed] to move the media to a position where it is easier to see.
- If you want to hold the media to check the test pattern, tap [Execute] next to [Sheet Cutting] to separate the media.

3. Tap [Save].

The entered correction value is saved.

4. Tap [Printing Test]>[Execute].

The test pattern is printed again.

5. Check the test pattern to see whether the correction was successful.

Check that the gap and overlap are the smallest for the figure indicated by "▲" (that is, the current correction value). If the gap and overlap are smaller for another figure, set the correction value again.

6. When you have successfully performed the correction, tap [Save and Proceed].

Step 10: Adjusting the Misalignment of the Ink Landing Position

This adjusts the landing position of the ink discharged from the print heads. The landing position varies according to the print head height and the thickness of the media, so we recommend that you make corrections to match the media you are using.

First, print a test pattern, and then determine and enter the correction value. After entering the correction value, print a test pattern again and check the correction results.

This adjustment must be performed in the following cases.

- When changing the media to use
- When the print head height was changed

Procedure

1. Tap [Printing Test]>[Execute].

Printing of the test pattern starts.

2. Check the printed test pattern, and then tap **-** or **+** to change the No. 1 and No. 2 H1 correction values.

Select the value that gives the least misalignment between the two lines. In the case of the following figure, select "+5" for H1 of No. 1 and No. 2. When you cannot choose between two sequential numbers, select a value that is between them (you can set correction values in units of "0.5").

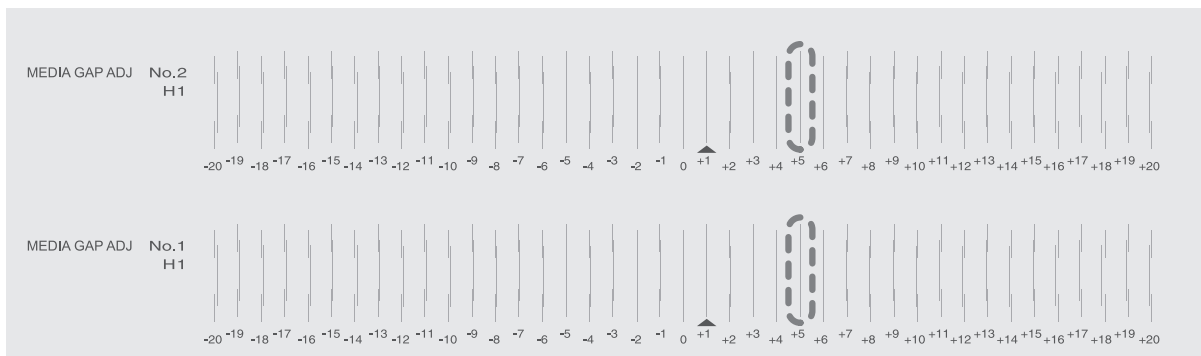

MEMO

- If the test pattern is difficult to see, tap **^** or **v** next to [Media Feed] to move the media to a position where it is easier to see.
- If you want to hold the media to check the test pattern, tap [Execute] next to [Sheet Cutting] to separate the media.

3. Tap [Save].

The entered correction value is saved.

4. Tap [Printing Test]>[Execute].

The test pattern is printed again.

5. Check the test pattern to see whether the correction was successful.

For all the correction values, check that the misalignment is minimized for the two vertical lines indicated by "▲" (that is, the current correction value). If the misalignment is smaller for another set of vertical lines, set the correction value again.



6. When you have successfully performed the correction, tap [Save and Proceed].

Step 11: Configuring the Settings to Dry the Trailing Edge of the Printing Area

When this setting is selected, the media is fed after printing until the trailing edge of the printing area is on the dryer. This allows the ink up to the trailing edge of the printing area to fully dry.

Procedure

1. Tap  to turn the setting on or off.

[Drying Feed][(Printing Only)]	This setting applies to output data designed only for printing. This setting is ignored for output data designed for printing and cutting. The margin between the print-end position and the next print-start position is set to a value of 130 mm (5.12 in.) when [Extended Dryer] is set to [Disable] and 310 mm (12.20 in.) when it is set to [Enable].
[Drying Feed][(Printing amp; Cutting)]	This setting applies to output data designed for printing and cutting. This setting is ignored for output data designed only for printing.
 (On)	Media feed is performed until the trailing edge of the printing area is positioned on the dryer.
 (Off)	Media feed stops when printing ends. This means that the trailing edge of the printing area is not fed to the dryer unless you continue with a subsequent printing operation.

2. Tap  or  to set the [Drying Feed][(Printing Only)] or [Drying Feed][(Printing amp; Cutting)] drying time.

MEMO

Drying Time

- The next operation is not started until the set time elapses.
- Tap [Skip] during drying to finish the drying time and start the next operation.
- If the drying time has been set in the RIP software, priority is given to the RIP software setting.
- If [Drying Time] is set to a value other than [0 min] and [Drying Feed] is off, the machine waits for the set time at the print-end position before starting the next operation.

3. Tap [Save and Proceed].

MEMO

Default setting:

- [Drying Feed][(Printing Only)]: Cleared
- [Drying Feed][(Printing amp; Cutting)]: Cleared
- [Drying Time][(Printing Only)]: [0 min.]
- [Drying Time][(Printing amp; Cutting)]: [0 min.]

Step 12: Setting the Ink Drying Time

This setting is used to extend the drying time when the ink dries poorly even if the dryer is used.

Procedure

1. Tap  or  to change the value.

Larger values cause the media to move more slowly, extending the drying time accordingly.

2. Tap [Save and Proceed].

MEMO

- Default setting: [Off]
- Depending on the RIP software you are using, you can also configure this setting in the RIP software. If you have configured the setting in the RIP software, the printer's setting is ignored.

Step 13: Fine-tuning the Cutting Conditions

You can accurately set items such as the blade force, movement speed, and blade offset to match the nature of the media and the shape to cut. First, perform a cutting test, and then determine and enter the setting values. After entering the setting values, perform a cutting test again and check the results. Repeat the process of performing a cutting test and making the settings several times to find the optimal setting values.

Procedure



1. Tap [Execute] next to [Cutting Test].

The test pattern is cut.

2. Check the results of the cutting test.

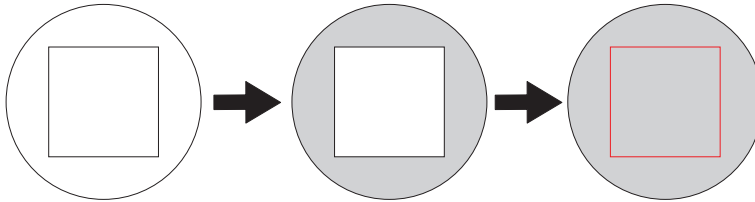
Check that the two shapes are peeled off separately, a blade trace (red line) remains on the backing paper, and the backing paper is not cut.



Check item	Result	Setting item	Adjustment
Check the shape.	The cut shape is distorted.	[Cutting Speed]	Reduce
Peel off the circle.	The square also peels off.	[Blade Force]	Increase
	Some uncut areas remain.	[Cutting Speed]	Reduce
Peel off the square.	The blade leaves faint traces on the backing paper.	[Blade Force]	No change
	The blade trace is indistinct.		Increase
	The blade trace is too deep and cuts into the backing paper.		Reduce
Check the shape of the square you have peeled off.	 The corners are not rounded and do not have "horns."	[Blade Offset]	No change
	 The corners are rounded.		Increase
	 The corners have "horns."		Reduce

3. Tap  or  to change the settings.

Setting item	Setting details	Default setting
[Blade Force]	Set the force (pressure) of the blade.	50 gf (0.11 lbf)
[Cutting Speed]	Set the speed of cutting.	30 cm/s (11.81 in./s)
[Blade Offset]	Set the blade offset. Enter the listed offset value for the blade. The offset value for the included blade is 0.250 mm (9.8 mil).	0.250 mm (9.84 mil)

Batch Settings for Output

Setting item	Setting details	Default setting
[Rise Movement Speed]	Set the blade's up speed during cutting (the speed at which the blade travels when it moves to the next cutting line after cutting one cutting line). If the media comes loose during no-load feed and the blade damages the surface of the media, reduce the speed.	30 cm/s (11.81 in./s)

4. Tap [Save and Proceed].

Step 14: Correcting the Reading Sensor

Depending on the characteristics of the media, such as reflectivity and colors, the machine may not be able to read the media width. In such cases, correct the sensor for reading the media.

Procedure

1. Tap [Execute].
2. Perform the operations shown below according to the [Adjustment Result].
 - If [Successful] is displayed on the operation panel, proceed to the next procedure.
 - If [Failed] is displayed on the operation panel, the following causes are possible, so take countermeasures and redo the correction.

Cause	Countermeasures
The lighting in the room where the printer is installed or vicinity of the printer is too bright.	Adjust the lighting in the room.
Correction failed for some reason.	Redo the correction.
Crop marks cannot be recognized due to the characteristics (reflectivity and colors) of the media.	To cut with crop marks, try the following. <ul style="list-style-type: none"> • Are you using media that is likely to reflect light or has deep colors?(P. 368) • Are you using transparent media?(P. 368)
There is ink on the multi sensor because, for example, the media strikes it immediately after printing.	Contact your authorized dealer.

3. Tap [Next].

Step 15: Correcting the Misalignment of Printing and Cutting

This is a correction method performed when printing followed immediately by cutting yields positioning for printing and cutting that is slightly misaligned.

Print alignment marks, perform detection of the printed marks, and then correct the discrepancy. Subtle misalignment between the printing and cutting positions may occur due to the thickness of the media or the print head height. We recommend that you make corrections to match the media you are using.

Procedure

1. Tap [Execute] next to [Printing Test 1(Misalignment Check)].

Printing Test 1 is printed and cut. The test pattern is printed at each edge of the media.

MEMO

If the media is tilted, the positions at the edges will be misaligned. You can also adjust for misalignments due to the media being tilted by printing the test pattern at each edge.

2. Check the result of Printing Test 1.

Check whether the printing position (shaded part) and the cutting position (red line) are aligned. An example of the printing position and the cutting position being misaligned is shown in the following figure.

[F] indicates the feed direction of the media (the feed direction) and [S] indicates the direction of print head carriage movement (the scan direction).

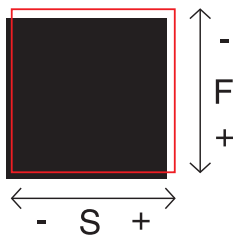

If the printing position and the cutting position are aligned, no corrections are necessary. Proceed to step 8.

If the printing position and the cutting position are not aligned, proceed to the next procedure.

3. Tap [Execute] next to [Printing Test 2(Correction Values)].

Printing Test 2 is printed and cut.

4. Check the correction values from the Printing Test 2 condition.

The point where the cutting line (A) intersects the correction-value scale (B) is the correction value. In the following figure, the correction value is "-0.3."

Check the media feed direction (the feed direction) and the direction of print-head carriage movement (the scan direction).

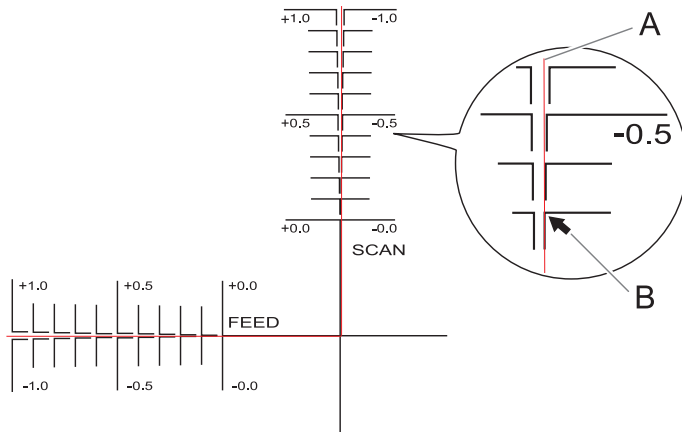

5. Set the correction values in the feed direction of the media (the feed direction) and the direction of print-head carriage movement (the scan direction).
 - (1) Tap **-** or **+** next to [Correction Value (Feed)] to set the correction value in the feed direction of the media (the feed direction).
 - (2) Tap **-** or **+** next to [Correction Value (Scan)] to set the correction value in the direction of print head carriage movement (the scan direction).
6. Tap [Save].
The correction values are saved.
7. Tap [Execute] next to [Printing Test 1(Misalignment Check)].
Printing Test 1 is printed and cut. If the printing and cutting lines are aligned, adjustment is complete. If further adjustment is needed, tap **-** or **+** next to [Correction Value (Feed)] and [Correction Value (Scan)] to fine-tune the printing and cutting position, and then [Save] the values.

MEMO

Default settings

- [Correction Value (Feed)] (correction value of the media feed direction): 0.00 mm
- [Correction Value (Scan)] (correction value of the print-head carriage movement direction): 0.00 mm

8. Tap [Save and Proceed].

Step 16: Correcting the Misalignment of Printing and Cutting with Crop Marks (Concurrent Test for Printing and Cutting with Crop Marks)

Use the following procedure to print the crop marks and cut the media, checking for misalignment in the positions. In this section, the crop marks are printed simply, and then the crop marks are read and a cutting test is performed without removing the media.

MEMO

When performing a separation test for cutting with crop marks, perform [Step 17: Correcting the Misalignment of Printing and Cutting with Crop Marks \(Separate Test for Printing and Cutting with Crop Marks\)\(P. 246\)](#).

✎ Correcting the Misalignment of Printing and Cutting with Crop Marks at the Same Time

Procedure

1. Tap next to [Separate Test for Printing/Cutting with Crop Marks] to turn it off.

2. Tap [Execute] next to [Printing Test 1(Misalignment Check)].

Printing Test 1 is printed and cut. One test pattern is printed on the media.

3. Check Printing Test 1.

Check whether the printing position (shaded part) and the cutting position (red line) are aligned. An example of the printing position and the cutting position being misaligned is shown in the following figure.

[F] indicates the feed direction of the media (the feed direction) and [S] indicates the direction of print head carriage movement (the scan direction).

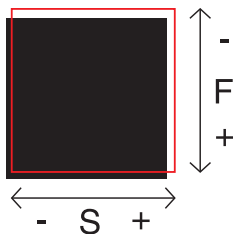

If the printing position and the cutting position are aligned, no corrections are necessary. Proceed to step 9.

If the printing position and the cutting position are not aligned, proceed to the next procedure.

4. Tap [Execute] next to [Printing Test 2(Correction Values)].

Printing Test 2 is printed and cut.

5. Check the correction values from the Printing Test 2 condition.

The point where the cutting line (A) intersects the correction-value scale (B) is the correction value. In the following figure, the correction value is "-0.3."

Check the media feed direction (the feed direction) and the direction of print-head carriage movement (the scan direction).

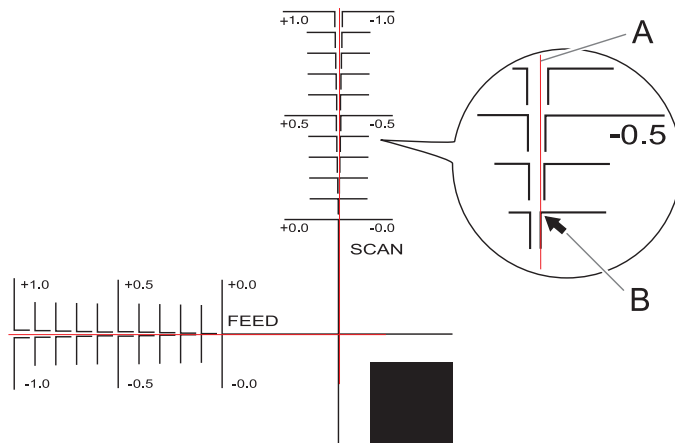

6. Set the correction values in the feed direction of the media (the feed direction) and the direction of print-head carriage movement (the scan direction).
 - (1) Tap **-** or **+** next to [Correction Value (Feed)] to set the correction value in the feed direction of the media (the feed direction).
 - (2) Tap **-** or **+** next to [Correction Value (Scan)] to set the correction value in the direction of print head carriage movement (the scan direction).
7. Tap [Save].
The correction values are saved.
8. Tap [Execute] next to [Printing Test 1(Misalignment Check)].
Printing Test 1 is printed and cut. If the printing and cutting lines are aligned, adjustment is complete. If further adjustment is needed, tap **-** or **+** next to [Correction Value (Feed)] and [Correction Value (Scan)] to fine-tune the printing and cutting position, and then [Save] the values.

MEMO

- Default settings
 [Correction Value (Feed)] (correction value of the media feed direction): 0.00 mm
 [Correction Value (Scan)] (correction value of the print-head carriage movement direction): 0.00 mm
- Depending on the changes in the condition of media caused by laminating and the loading position of the media before cutting, the positioning of cutting may be misaligned. In such cases, correct the misalignment of printing and cutting with crop marks.

9. Tap [Save and Proceed].
Proceed to [Step 18: Cutting to Make It Possible to Cut Corners Attractively \(Over Cut\)\(P. 250\)](#).

RELATED LINKS

- [P. 246 Correcting the Misalignment of Printing and Cutting with Crop Marks \(Separate Test for Printing and Cutting with Crop Marks\)](#)

Step 17: Correcting the Misalignment of Printing and Cutting with Crop Marks (Separate Test for Printing and Cutting with Crop Marks)

Due to changes in the thickness of media caused by laminating and misalignment of the loading position of the media before and after cutting, the positioning of printing and cutting may be misaligned even when you are using crop marks. Make corrections for misaligned printing and cutting for the media you are using and its condition.



In this test, so as to create the same conditions as the actual operation, print only the crop marks, remove the media, load the media again, and then cut the media.

MEMO

- To perform a concurrent test for printing and cutting with crop marks, perform [Step 16: Correcting the Misalignment of Printing and Cutting with Crop Marks \(Concurrent Test for Printing and Cutting with Crop Marks\)](#)(P. 244).
- The required pre-print margin for [Separate Test for Printing/Cutting with Crop Marks] is at least 75 mm (2.96 in.), and the required post-print margin is at least 130 mm (5.12 in.).

1. Print only the crop marks.

Procedure

1. Tap  next to [Separate Test for Printing/Cutting with Crop Marks] to turn it on.
2. Tap [Execute] next to [Printing Test].
Printing of the test pattern starts.
The crop marks are printed. When printing is finished, you will return to the original screen.
3. Remove any media.
Use the following procedure to separate the media.
 - (1) Close the front cover.
 - (2) Tap [Change] next to [Output Start Location].
 - (3) Tap  to feed the media until there is a margin of 130 mm (5.12 in.) or more after the printed crop marks.
 - (4) Tap  to go back to the previous screen.
 - (5) Tap [Execute] next to [Sheet Cutting].
 - (6) Tap [Yes] on the confirmation screen.
4. Complete operations before cutting output for normal cutting with crop marks, such as laminating.

2. Performing a Cutting Test

Procedure

1. Set up the media for which operations before cutting output, such as lamination, is complete. Begin setting from [Step 1: Configuring \[Batch Media Settings\]\(P. 222\)](#) again.

2. Tap next to [Separate Test for Printing/Cutting with Crop Marks] to turn it on .

3. Tap [Execute] next to [Cutting Test].
The [Move the blade over a crop mark.] window appears.

4. Tap , , , or to move the center of the blade over the crop marks to use in the cutting test.

The center of the blade should only be over the crop marks, and does not need to be aligned with the center of the crop marks.

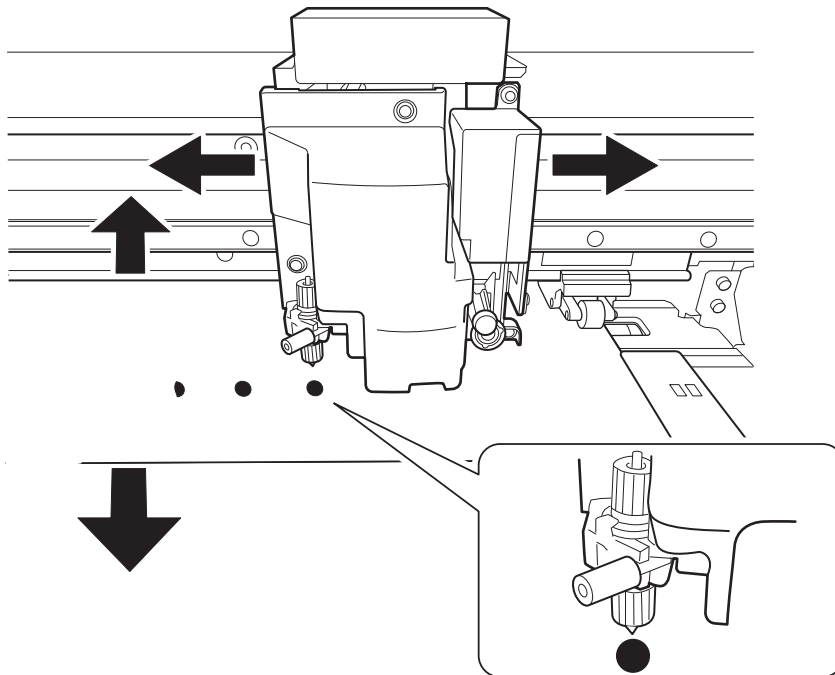

5. Tap [Execute].
The cutting test starts.

3. Setting the Correction Values

Procedure

1. View the results of the cutting test to determine the correction values.

Check whether the crop mark (shaded part) and the cutting position (red line) are aligned. An example of the crop mark and the cutting position being misaligned is shown in the following figure.

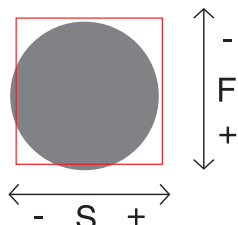

- If the test printed crop marks are inside the cutting line, correction is not necessary. Proceed to step 5.
- If the test printed crop marks are extending beyond the cutting line, correction is necessary.

[F] indicates the feed direction of the media (the feed direction) and [S] indicates the direction of print-head carriage movement (the scan direction). ("F," "S," "+," "-", and the arrows are not displayed on the actual test pattern.)

MEMO

Determine the values so as to correct the misalignment of the cutting position. In the case of the above figure, feed direction [F] is misaligned in a negative direction and scan direction [S] in a positive direction. Therefore, set the correction values for the feed direction [F] to positive values and the scan direction [S] to negative values. Measure the actual misalignment amount when determining the value.

2. Set the correction values in the feed direction of the media (the feed direction) and the direction of print-head carriage movement (the scan direction).
 - (1) Tap **-** or **+** next to [Correction Value (Feed)] to set the correction value in the feed direction of the media (the feed direction).
 - (2) Tap **-** or **+** next to [Correction Value (Scan)] to set the correction value in the direction of print head carriage movement (the scan direction).

3. Tap [Save].

4. Perform Steps 3 to 5 of [2. Performing a Cutting Test\(P. 247\)](#) again, and check whether or not correction was successful.
 - If the test printed crop marks are inside the cutting line, correction is complete.
 - If the test printed crop marks are extending beyond the cutting line, redo the correction.

MEMO

- Default settings
 - [Correction Value (Feed)] (correction value of the media feed direction): 0.00 mm
 - [Correction Value (Scan)] (correction value of the print-head carriage movement direction): 0.00 mm
- You can also make corrections of printing and cutting positions at the same time without removing the media.

5. Tap [Save and Proceed].

RELATED LINKS

- [P. 244 Correcting the Misalignment of Printing and Cutting with Crop Marks \(Concurrent Test for Printing and Cutting with Crop Marks\)](#)

Step 18: Cutting to Make It Possible to Cut Corners Attractively (Over Cut)

The corners of the border of the cutting line can be cut slightly longer so that the corners can be cut attractively.

This is effective when using laminated or thick media, or non-resilient media. It also has the effect of making stickers easier to peel off.

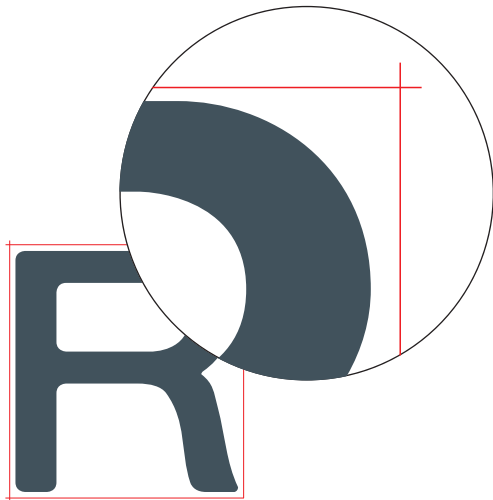

Procedure

1. Tap [Enable].
2. Tap [Save and Proceed].

MEMO

- Default setting: [Disable]
- The cutting start point is not over cut.

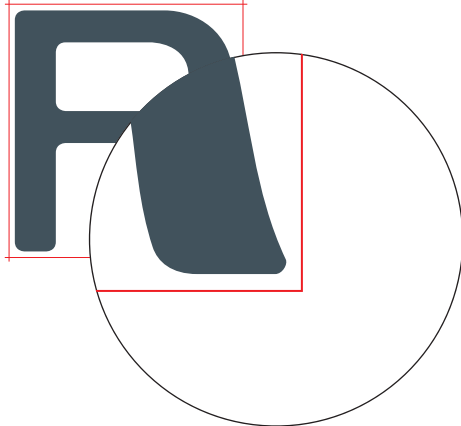

Step 19: Setting the Printing Movement Range

This shortens output time by reducing the width of print-head carriage movement to the minimum necessary. This is effective when the width of the media or the output data is narrow.

Procedure

1. Specify the range of print-head carriage movement during printing.

[Output Data Width]	Matches the range of print-head carriage movement to the output data. Movement is limited to the minimum amount necessary, and this can be expected to yield the fastest output. Note, however, that because the speed of media movement is no longer constant, colors may be uneven.
[Media Width]	"SHEET" matches the range of print-head carriage movement to the width of the media.
[Full Width]	The print-head carriage moves from one end of the machine to the other. Makes the speed of media movement constant at all times and produces the most stable printing result.

MEMO

- Default setting: [Full Width]

2. Tap [Save and Exit].
3. Tap  to return to the home screen.

Managing the Media Settings

Changing the Media Settings

Use the following procedure to change the media settings. These settings can only be changed for the media being set up.

Procedure

1. Set up the media.
2. Tap .
3. [Media Settings]>[List of Media Settings]
4. Tap the setting to change to move to the screen for editing this setting.

The media settings that can be changed are as follows.

Menu item	Reference page
[Print Head Height]	P. 180 Changing the Print Head Height
[Feed Correction]	P. 176 Manual Adjustment: Reducing Horizontal Bands (Feed Correction)
[Media Gap Adjustment]	P. 178 Manual Adjustment: Adjusting the Misalignment of the Ink Landing Position (Media Gap Adjustment)
[Blade Adjustment]	P. 200 Fine-tuning the Cutting Conditions
[Print & Cut Position Adjustment]	P. 207 Correcting the Misalignment of Printing and Cutting
[Crop Cut Position Adjustment]	P. 212 Correcting the Misalignment of Printing and Cutting with Crop Marks (Concurrent Test for Printing and Cutting with Crop Marks) P. 215 Correcting the Misalignment of Printing and Cutting with Crop Marks (Separate Test for Printing and Cutting with Crop Marks)
[Cutting Distance Correction]	P. 204 Performing Distance Correction during Cutting
[Over Cut]	P. 205 Cutting to Make It Possible to Cut Corners Attractively (Over Cut)
[Heater Temperature]	P. 190 Setting the Print Heater Temperature P. 192 Setting the Dryer Temperature
[Dry After Printing]	P. 196 Drying the Trailing Edge of the Printing Area on the Dryer
[Multi Sensor Adjustment]	P. 220 Correcting the Reading Sensor
[Drying Time Per Scan]	P. 182 Using Hard-to-Dry Media
[Media Suction Force]	P. 183 Using Media That Wrinkles Easily/Does Not Move Smoothly

Menu item	Reference page
[Printing Movement Range]	P. 262 Speeding Up Output for Narrow Media
[Media Sticking Prevention]	P. 184 Using Sticky Media
[Middle Pinch Auto Raise/Lower]	P. 187 Use Middle Pinch Rollers When Pulling Back or Feeding Media

5. If you have changed a setting, tap [Save].

6. Tap  to return to the home screen.

Checking the Registered Media Settings

Procedure

1. Tap .
2. Tap [Media Management].
The registered media are displayed in a list.
3. Tap a media setting.
4. Tap [List of Media Settings].
The registered media setting values are displayed in a list.



Menu item	Reference page
[Print Head Height]	P. 180 Changing the Print Head Height
[Feed Correction]	P. 176 Manual Adjustment: Reducing Horizontal Bands (Feed Correction)
[Media Gap Adjustment]	P. 178 Manual Adjustment: Adjusting the Misalignment of the Ink Landing Position (Media Gap Adjustment)
[Blade Adjustment]	P. 200 Fine-tuning the Cutting Conditions
[Print & Cut Position Adjustment]	P. 207 Correcting the Misalignment of Printing and Cutting
[Crop Cut Position Adjustment]	P. 212 Correcting the Misalignment of Printing and Cutting with Crop Marks (Concurrent Test for Printing and Cutting with Crop Marks) P. 215 Correcting the Misalignment of Printing and Cutting with Crop Marks (Separate Test for Printing and Cutting with Crop Marks)
[Cutting Distance Correction]	P. 204 Performing Distance Correction during Cutting
[Over Cut]	P. 205 Cutting to Make It Possible to Cut Corners Attractively (Over Cut)
[Heater Temperature]	P. 190 Setting the Print Heater Temperature P. 192 Setting the Dryer Temperature
[Dry After Printing]	P. 196 Drying the Trailing Edge of the Printing Area on the Dryer
[Multi Sensor Adjustment]	P. 220 Correcting the Reading Sensor
[Drying Time Per Scan]	P. 182 Using Hard-to-Dry Media
[Media Suction Force]	P. 183 Using Media That Wrinkles Easily/Does Not Move Smoothly
[Printing Movement Range]	P. 262 Speeding Up Output for Narrow Media
[Media Sticking Prevention]	P. 184 Using Sticky Media

Menu item	Reference page
[Middle Pinch Auto Raise/Lower]	P. 187 Use Middle Pinch Rollers When Pulling Back or Feeding Media

5. Tap  to return to the home screen.

Changing the Media Name



Procedure

1. Tap .
2. Tap [Media Management].
The registered media are displayed in a list.
3. Tap the media whose name you want to change.
4. Tap .
5. Tap the input field and enter the media name.
6. Tap [OK] to confirm your entry.
7. Tap  to return to the home screen.

Duplicating Media Settings

Use the following procedure to duplicate existing media settings.



Procedure

1. Tap .
2. Tap [Media Management].
The registered media are displayed in a list.
3. Tap the media to duplicate.
4. Tap [Duplicate Media].
A screen for entering the name of the duplicated media appears. To create this name, [COPY] is added at the start of the name of the media being duplicated.
5. Enter the media name and tap [OK].
6. Tap  to return to the home screen.

Duplicating Media Settings for Cutting

Use the following procedure to duplicate existing media settings for cutting.

Procedure

1. Tap .
2. Tap [Media Management].
The registered media are displayed in a list.
3. Tap the media to duplicate.
4. Tap [Duplicate as Media for Cutting].
 - A screen for entering the name of the duplicated media appears. To create this name, [COPY] is added at the start of the name of the media being duplicated.
 - The media setting is duplicated with the settings configured so the heater power is off.
5. Enter the media name and tap [OK].
6. Tap  to return to the home screen.



Deleting Media Settings

Use the following procedure to delete existing media settings.

MEMO

This operation cannot be performed on the media being set up. To perform this operation, first cancel media setup.

Procedure

1. Tap .
2. Tap [Media Management].
The registered media are displayed in a list.
3. Tap the media to be deleted.
4. Tap [Delete Media].
5. Tap [Yes] when the confirmation screen appears.
The media settings are deleted, and you are returned to the screen listing the registered media settings.
6. Tap  to return to the home screen.

Adjusting the Output-start Location

Setting the Base Point

Set the base point to determine the printing area on the set up media.

The base point (④) indicates the right edge of the printing area (①). (②: Media feed direction, ③: print-head carriage movement direction) You can print without setting the base point, but setting the printing area enables you to use media without being wasteful and also to print on the targeted location.



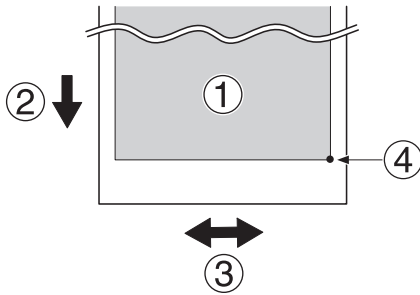







Make this setting for each individual page. When the printing of one page finishes, the base point returns to its default value.



MEMO

- Note that the left and right positions are not restored to their defaults for test patterns.

Procedure

1. Tap .
2. Tap  [Move].
The movement screen appears.
3. Tap .
4. Tap     and move the cutter center to the position where you want to start cutting.
Tap  or  to move the media in the feed direction (forward-back). Tap  or  to move the cutting carriage in the scan direction (left-right).

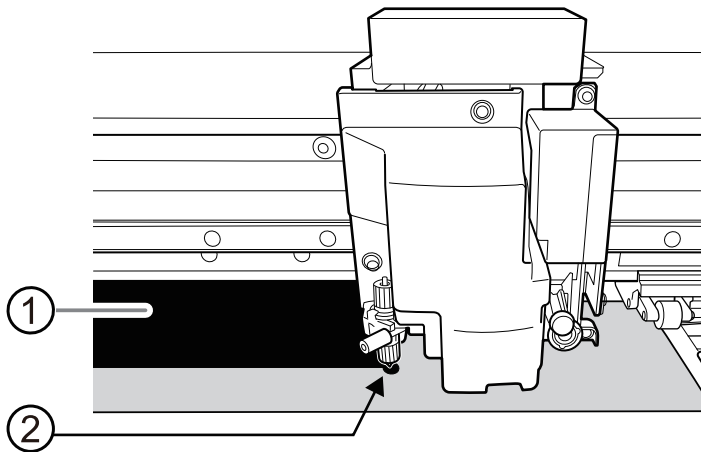

- ①: Printing area
- ②: Base point (right edge of the printing area)

5. Once the position has been decided, tap [Set Base Point Here] to confirm it.
The base point position is updated, and you are returned to the home screen.

MEMO

The icon below is displayed to indicate that the base point position has been updated.



Base

W : 1600 mm

L : --- m

Reducing Output Time

Speeding Up Output for Narrow Media

This shortens output time by reducing the width of print-head carriage movement to the minimum necessary. This is effective when the width of the media or the output data is narrow.

Procedure

1. Set up the media.
2. Tap .
3. Tap [Media Settings]>[Other Media Settings]>[Printing Movement Range].
4. Specify the range of print-head carriage movement during printing.

[Output Data Width]	Matches the range of print-head carriage movement to the output data. Movement is limited to the minimum amount necessary, and this can be expected to yield the fastest output. Note, however, that because the speed of media movement is no longer constant, colors may be uneven.
[Media Width]	"SHEET" matches the range of print-head carriage movement to the width of the media.
[Full Width]	The print-head carriage moves from one end of the machine to the other. Makes the speed of media movement constant at all times and produces the most stable printing result.

5. Tap [Save] to confirm your entry.
6. Tap  to return to the home screen.

MEMO

- Default setting: [Full Width]

Printing with Crop Marks

Use your RIP software to configure the settings for printing crop marks. For information on how to configure the settings, refer to the documentation for the RIP software you are using.

IMPORTANT

Alignment marks and symbols drawn using graphics software cannot be used as crop marks.

When using VersaWorks, the crop marks are printed as shown in the figure.

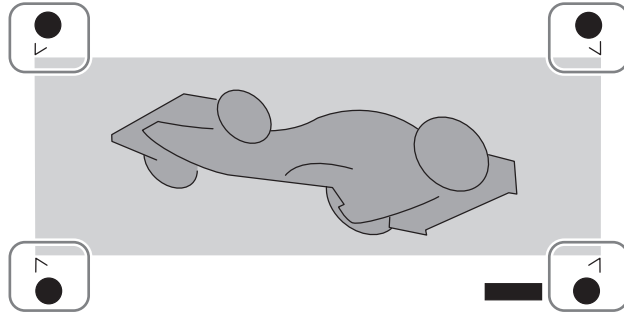

Managing VersaWorks Jobs

Outputting a Job

From the operation panel, perform [VersaWorks] and [Queue Folder] via Roland DG Connect Hub, and then print the job.

First, check the following items:

- Roland DG Connect Hub version 3.2.0 or later is installed on the computer where VersaWorks is installed.
- The VersaWorks version is 7.3.0 or later.
- Roland DG Connect Hub has started, and you have signed in.
- VersaWorks is running.
- The printer is ready to print (media has been set up).

Procedure

1. Tap .
2. Tap [Job Management]>[Direct Printing].
The VersaWorks list (VersaWorks nicknames that were set with Connect Hub) is displayed.
3. Tap the desired VersaWorks.
A list of the queue folders is displayed.
4. Tap the desired queue folder.
The job list is displayed.

MEMO

Tap  to update the job and get the latest job status information.

5. Tap the job you want to print.
6. Tap [Execute].
The job is printed.

Displaying the [Printing Log]

Displays [Printing Log].

The [Job Properties] for each job and the [Total Time] and [Total Area] for all jobs, can be checked. First check whether VersaWorks is version 7.5.0 or later.

Procedure

1. Tap .
2. Tap [Job Management]>[Printing Log].
The following is displayed.

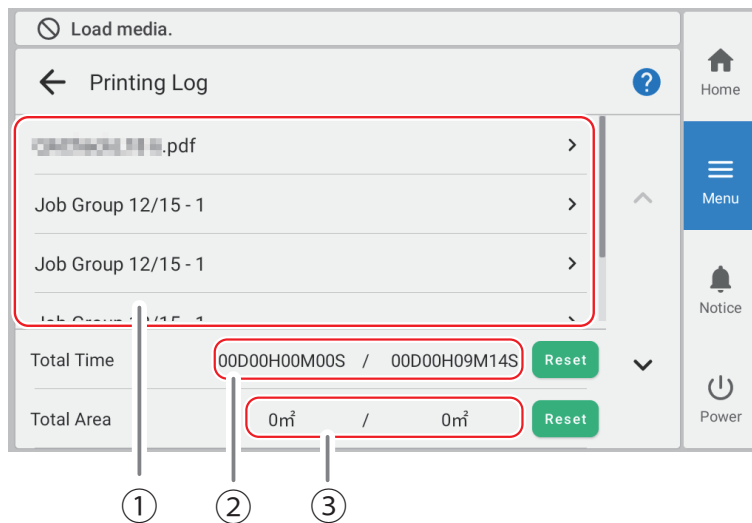

①	[Printing Log]
②	<p>[Total Time] */* is displayed. The left side indicates the trip [Total Time], and the right side indicates the total [Total Time].</p> <ul style="list-style-type: none"> • Trip [Total Time] Displays the total printing hours for any period of time, such as daily or weekly. To reset to 0, tap [Reset]. Reset when you wish to start measurement. • Total [Total Time] Displays the total cumulative printing time. This function cannot be reset.
③	<p>[Total Area] */* is displayed. The left side indicates the trip [Total Area], and the right side indicates the total [Total Area].</p> <ul style="list-style-type: none"> • Trip [Total Area] Displays the total printing area for any period of time, such as daily or weekly. To reset to 0, tap [Reset]. Reset when you wish to start measurement. • Total [Total Area] Displays the total cumulative printing area. This function cannot be reset.



3. To check the [Job Properties] for a specific job, select the job.
The [Job Properties] appears.
4. Tap  to return to the home screen.

Other Useful Functions

Performing Printing Tests Arranged Horizontally

When performing printing tests successively, you can select [Feed] (vertical printing) or [Scan] (horizontal printing) as the print position for the second and later tests in comparison to the first test.

Procedure

1. Tap .
2. Tap [Preferences]>[Printing Test Position].
3. Select [Scan].
4. Tap [Save] to confirm your entry.
5. Tap  to return to the home screen.

MEMO

- Default setting: [Feed]

Changing the Operation Panel Color Theme

Follow the procedure below to change the operation panel color scheme.

Procedure

1. Tap .
2. Tap [System Information]>[Appearance].
3. Select [Dark] or [Light].
4. Tap [Save] to confirm your entry.
You are returned to the home screen.



MEMO

Default setting: [Light]

Displaying the 2D Code for Viewing the Manual on the Operation Panel

Displays the 2D code for viewing the manual using a smartphone or other mobile terminal.



Procedure

1. Tap .
2. Tap [System Information]>[2D Codes]>[User's Manual].
The 2D code is displayed.
3. Scan the 2D code with the smartphone.
The manual can be viewed.
4. Tap [OK].
5. Tap  to return to the home screen.

Displaying the Roland DG Connect 2D Code on the Operation Panel

Displays the 2D code for accessing [Roland DG Connect] using a smartphone or other mobile terminal.

Procedure

1. Tap .
2. Tap [System Information]>[2D Codes]>[Roland DG Connect].
The 2D code is displayed.
3. Scan the 2D code with the smartphone.
[Roland DG Connect] opens.
4. Tap [OK].
5. Tap  to return to the home screen.

Optimizing Operation Management

Managing the Operations Appropriately and Efficiently	271
Sounding a Buzzer to Notify the User of the End of Printing	271
Setting the Current Date/Time and Using It for Maintenance.....	272
Checking the Remaining Media.....	273
Printing the Amount of Remaining Media.....	274
Showing/Hiding Notifications	275
Determining What Happens When Ink Runs Out	276
Setting the Activation Interval for Sleep Mode (Power-saving Feature)	277
Setting the Duration of the Warning Beep	278
Managing the Basic Settings of the Printer	279
Set the display language	279
Changing the Units of Measurement	280
Viewing Printer Information	281
Viewing Network Information	282
Adjusting the Brightness of the Operation Panel.....	283
Turning Off Operation Panel Sounds.....	284
Returning All Settings to Factory Defaults	285

Managing the Operations Appropriately and Efficiently

Sounding a Buzzer to Notify the User of the End of Printing

You can configure the settings so that the user is notified of the end of printing with a buzzer.

Procedure

1. Tap .
2. Tap [Preferences]>[Sound at End of Printing].
3. Tap [On] to select it.

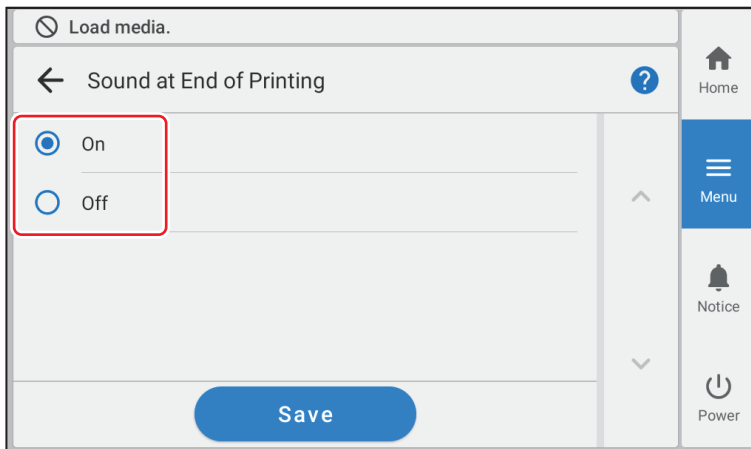

4. Tap [Save] to confirm your entry.
5. Tap  to return to the home screen.





MEMO

- Default setting: [Off]

Setting the Current Date/Time and Using It for Maintenance

Use the following procedure to set the current date and time. By setting this, when you perform a printing test the printing test date and time will be printed alongside the printed test pattern. Notifications prompting you to perform manual cleaning and mix the ink will also be displayed at appropriate times.

Procedure

1. Tap .
2. Tap [System Information]>[Date/Time].
3. Tap  or  to set the date and time.
4. Tap [Save] to confirm your entry.
5. Tap  to return to the home screen.

Checking the Remaining Media

You can display how much of the media in use is left. By setting the amount of media currently remaining at the start, the amount remaining will be constantly displayed on the screen until it reaches zero.

If you remove the media or cancel media loading by raising the loading lever, the amount remaining at that time flashes on the screen. Because the amount of media remaining is not updated automatically when you change the media, redo the setting whenever you change the media. You can also set the machine to display this menu automatically whenever you change the media.

MEMO



The remaining amount that is displayed is only an estimate. Accuracy is not assured.

Procedure

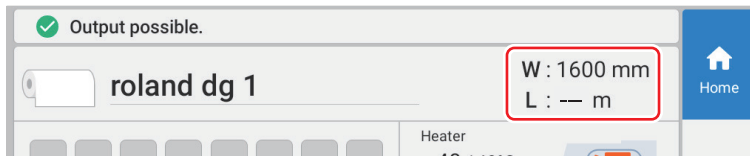
1. Set up the media.
2. Tap the following location on the home screen.



The [Remaining Media Management] screen appears.

3. Tap  or  to enter the length of the remaining media.
4. Tap [Save] to confirm your entry.
5. Tap  to return to the home screen.

The remaining media is displayed.

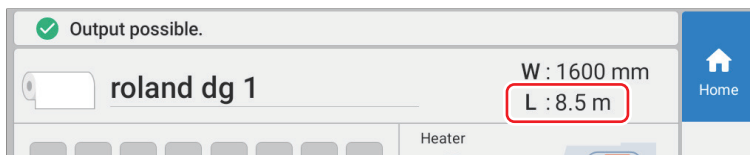

Printing the Amount of Remaining Media

Print the amount of remaining media, which is displayed on the home screen.

Use this when you want to make a record of the remaining length of the media currently in use. Printing the amount of media remaining before you change the media enables you to refer to the printed record and use the value to make the setting for the remaining amount the next time you use the media.

Note, however, that if you continue printing, the next printing operation will start on top of the portion where the amount of remaining media is printed. If you want to continue printing, separate the media before starting the next printing operation.

Procedure

1. Check that the amount of remaining media is displayed on the home screen.
If it is not, set the amount of remaining media by referring to [Checking the Remaining Media\(P. 273\)](#).

2. Tap the following location on the home screen.

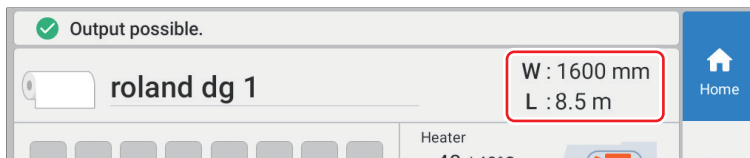



The [Remaining Media Management] window appears.

3. Tap [Printing Remaining Media Amount]>[Execute].
The amount of remaining media is printed.
4. Tap  to return to the home screen.

Showing/Hiding Notifications

Use the following procedure to show/hide the following notifications, which prompt operators to perform proper operations.

Procedure

1. Tap .
2. Tap [Preferences]>[Notifications On/Off].
3. Tap  to show/hide the notifications.

	Displayed notification	Description
[Ink Mixing Notification]* ¹	[The time for ink mixing has arrived.]	Prompts you to mix the ink cartridge to prevent ink precipitation. When this is on, a message recommending mixing the ink is displayed once a day.
[Middle Pinch Roller Placement Notification]	[Place the middle pinch rollers over all the grit rollers.]	Prompts you to use the middle pinch rollers, improving media feeding accuracy and preventing the media from coming loose. When this is on, the message appears when the middle pinch rollers have not been placed.
[Media Clamp Placement Notification]	[Install the media clamps correctly.]	Prompts you to correctly place the media clamps to prevent the media from coming loose. When this is on, the message appears when the media clamps are not placed appropriately at the edges of the media.
	[Media clamps could not be detected.]	This message appears when the media clamps cannot be detected because they are hidden by the media or are dirty with, for example, ink.

4. Tap [Save] to confirm your entry.
5. Tap  to return to the home screen.

MEMO

Default setting:

- [Ink Mixing Notification]: On*¹
- [Middle Pinch Roller Placement Notification]: On
- [Media Clamp Placement Notification]: On

*1 This menu item is only displayed when the machine ink type includes white ink.

Determining What Happens When Ink Runs Out

This menu lets you determine the operation that takes place when an ink cartridge becomes empty during printing. The print quality will be affected by the selected operation.

Procedure

1. Tap .
2. Tap [Preferences]>[Ink Empty Mode].
3. Tap [Stop] or [Continue].

[Ink Empty Mode]	Description
[Stop]	Printing is paused immediately when an ink cartridge becomes empty. Printing pauses, so colors may be uneven. To prevent uneven colors, ensure that a sufficient amount of ink remains before you begin printing.
[Continue]	A buzzer sounds when an ink cartridge becomes empty. Printing continues until all the data that this machine has received is printed. In this case, it is also possible to press [Pause] and pause printing.

4. Tap [Save] to confirm your entry.
5. Tap  to return to the home screen.





MEMO

Default setting: [Stop]

Setting the Activation Interval for Sleep Mode (Power-saving Feature)

This sets how long it takes until the machine goes into sleep mode (state in which the power-saving feature is active) when no print data is received and no operations are performed for a continued length of time.

Procedure

1. Tap .
2. Tap [Preferences]>[Sleep Time].
3. Tap  or  to set the time.
4. Tap [Save] to confirm your entry.
5. Tap  to return to the home screen.





MEMO

- Default setting: [30 min.]

Setting the Duration of the Warning Beep

This feature sets the duration of the warning beep that sounds when, for example, an error occurs. If you turn this timer off, the warning beep will continue until the cause of the problem is eliminated.

Procedure

1. Tap .
2. Tap [Preferences]>[Stopping the Warning Beep].
3. Tap  to switch the setting.
4. Tap  or  to set the time.
5. Tap [Save] to confirm your entry.
6. Tap  to return to the home screen.

MEMO

- Default setting: [Off]

Managing the Basic Settings of the Printer

Set the display language

This feature sets the language displayed on the operation panel.

Procedure

1. Tap .
2. Tap [System Information]>[Language].
3. Tap [Language].
4. Select the display language.
5. Tap [OK].
6. Tap [Save] to confirm your entry.

The display language is changed, and you are returned to the home screen.

MEMO



Default setting

- [Language]: ENGLISH

Changing the Units of Measurement

This feature sets the length and temperature units displayed on the operation panel.

Procedure

1. Tap .
2. Tap [System Information]>[Units].
3. Tap [Length].
4. Select the unit.
5. Tap [Save] to confirm your entry.
6. Tap [Temperature].
7. Select the unit.
8. Tap [Save] to confirm your entry.
9. Tap  to return to the home screen.



MEMO

- Default setting
 - [Length]: mm
 - [Temperature]: °C

Viewing Printer Information

This is the procedure for viewing machine information such as the serial number and ink type.

Procedure

1. Tap .
2. Tap [System Information]>[Machine Information].
You can check the following information:
 - [Model]: Model name
 - [Serial Number]: Serial number
 - [Ink Type]: Ink type
 - [Firmware Version]
 - [MAC Address]
3. Tap  to return to the home screen.

Viewing Network Information

Use the following procedure to view network information and settings such as the IP address and default gateway.

Procedure

1. Tap .

2. Tap [System Information]>[Network].

You can check the following information:

- [Obtain IP Address Automatically]: Enables/disables the automatic obtaining of IP addresses via DHCP. When this is disabled, tap  to change the following settings.
- [IP Address]
- [Subnet Mask]
- [Default Gateway]

3. Tap  to return to the home screen.

MEMO

- For information on how to set up a network, see the "Setup Guide."





RELATED LINKS

- [VG4-640/VG4-540 Setup Guide](#)

Adjusting the Brightness of the Operation Panel

The brightness of the operation panel's screen can be adjusted.

Procedure

1. Tap .
2. Tap [System Information]>[Screen Brightness].
3. Tap  or  to adjust the brightness.
The larger the value, the brighter the screen.
4. Tap [Save] to confirm your entry.
5. Tap  to return to the home screen.



MEMO

- Default setting: [100%]

Turning Off Operation Panel Sounds

The touch sounds for the operation panel can be turned off.

Procedure

1. Tap .
2. Tap [System Information]>[Screen Operation Sound].
3. Tap [Off].
The operation sound turns off.
4. Tap [Save] to confirm your entry.
5. Tap  to return to the home screen.

MEMO

- Default setting: [On]

Returning All Settings to Factory Defaults

This menu returns all settings, including registered media, to their factory defaults. The settings for [Language] and [Units] are not returned to their factory default values.

Procedure

1. Tap .
2. Tap [Preferences]>[Reset to Factory Defaults].
3. Tap [Reset].
4. Tap [Yes] on the confirmation screen.
The setting is reset and the screen returns to the home screen.

Maintenance

Introduction

Important Notes on Handling and Use	288
Printer	288
Ink Cartridges	288
Basic Maintenance Knowledge	290
Types and Timing of Maintenance	290
Automatic Maintenance Feature and Notes	292
Measures When the Printer Is Not in Use for a Prolonged Period	294

Important Notes on Handling and Use

Printer

- **This machine is a precision device.**
 - Never subject the machine to impacts or excessive force.
 - Never needlessly put your hand or fingers inside the cover, the ink-cartridge ports, or other internal areas of the machine.
- **Install the machine in a suitable location.**
 - Install the machine in a location having the specified temperature and relative humidity.
 - Install the machine in a quiet, stable location offering good operating conditions.
- **The print heads are delicate.**
 - Avoid needlessly touching them, allowing them to scrape against the media, or similar acts. Failure to handle with care may cause damage.
 - The print heads may be damaged if allowed to dry out. The machine prevents desiccation automatically, but improper operation may render this feature inoperative. Operate properly, as specified in this manual.
 - Never leave the machine with an ink cartridge removed. Remaining ink in the printer may harden and clog the print heads.
 - Daily maintenance as well as various types of maintenance depending on the status must be performed. Read this manual thoroughly and perform the appropriate maintenance at the appropriate times.
 - The print heads are components that wear out. Periodic replacement is required, with the frequency of replacement depending on use.
- **Keep the operation panel clean.**
 - If dirt or ink adheres to the operation panel, immediately wipe it clean with dry, soft fabric.
- **This machine becomes hot.**
 - Never cover the ventilation holes with cloth, tape, or anything else.

Ink Cartridges

WARNING

Never store ink, cleaning liquid, or discharged fluid in any of the following locations.

- Any location exposed to open flame
- Any location where high temperature may occur
- Near bleach or any other such oxidizing agent or explosive material
- Any location within the reach of children

Fire may be a danger. Accidental ingestion by children may pose a health hazard.

- **Ink cartridges come in various types.**
 - Use a type that is compatible with the printer. Also, be sure to use only genuine items from Roland DG Corporation.
- **Never subject the ink pouches to impacts or attempt to disassemble them.**
 - Never drop the ink cartridges or shake them forcefully. The impact may rupture the internal pouches and cause the ink to leak.
 - Never attempt to disassemble.
 - Never attempt to refill the ink.

- If ink gets on your hands or clothing, wash it off as soon as possible. Removal may become difficult if you leave such adhered ink untreated.
- **Storage**
 - Use up the ink before the expiration date printed on the ink cartridge.
 - Store the ink cartridge in a location that is not subject to direct sunlight or strong illumination.
 - Store unopened in a well-ventilated location at a temperature of 5 to 30°C (41 to 86°F).

Basic Maintenance Knowledge

Types and Timing of Maintenance

To use this machine under its optimal conditions, it is important to perform the appropriate maintenance at the appropriate times.

Regular Maintenance

These are the maintenance items that are required on a daily basis.

Timing	Category	Item
Before daily operations	Print head check	P. 296 Print Head Check before Printing
	Ink mixing (white ink)	Remove just the ink cartridge for the white ink, shake it 50 times (about 20 seconds), and then reinsert this cartridge.
After daily operations	Cleaning the machine	P. 298 Cleaning the Media Path
		P. 299 Cleaning the Cutting Carriage Roller
If a message appears	Cleaning around the print heads	P. 300 Cleaning around the Print Heads
If the discharged fluid disposal message appears	Disposing of discharged fluid	P. 315 If the Discharged Fluid Disposal Message Appears

Advanced Maintenance

Maintenance that is performed in an emergency. Some of this maintenance consumes a large amount of ink, so thoroughly read the explanation, and then perform the operation at the appropriate point in time.

Timing	Category	Item
When dot drop-out or dot displacement occurs	Checking and cleaning the print heads	P. 318 Normal Cleaning Method
		P. 320 Medium Cleaning Method
		P. 322 Powerful Cleaning Method
		P. 301 Manual Cleaning Method
When dot drop-out and dot displacement are not resolved even by performing the above operations	Replacing the ink in all the ink paths*1	P. 327 Ink Renewal Method
When uneven color issues occur (other than white ink)	Eliminating drops in ink concentration	P. 129 Preventing Sedimentation in Inks
		P. 324 Light Choke Cleaning Method
		P. 327 Ink Renewal Method

Timing	Category	Item
When uneven color issues occur (white ink)	Eliminating drops in ink concentration	P. 129 Preventing Sedimentation in Inks
		P. 326 Ink Circulating Method
		P. 324 Light Choke Cleaning Method
		P. 327 Ink Renewal Method

*1 This cleaning consumes a large amount of ink.

Replacing Consumable Parts

These items are for replacement of consumable parts. Thoroughly read the explanation, and then perform the operation at the appropriate point in time.

Timing	Category	Item
When a replacement message appears	Replacing consumable parts <ul style="list-style-type: none"> • Wiper • Wiper cleaner • Flushing sponge • Print head cap 	P. 337 Replacing the Wiper
		P. 340 Replacing the Wiper Cleaner
		P. 344 Replacing the Flushing Sponges
		P. 342 Replacing the Print Head Caps
When a cutting edge becomes dull	Blade	P. 346 Replacing the Blade
	Separating knife	P. 352 Replacing the Separating Knife

Automatic Maintenance Feature and Notes

This machine has a feature that automatically performs maintenance periodically.

Set the maintenance items that are performed automatically and the [Type] and [Frequency] according to the printer service environment, types of products that are frequently output, and other factors. A maximum of five settings for automatic maintenance can be saved.

This function performs operations for preventing the print heads from drying out, so:

- Always keep the main power switched on.
- Do not leave the front, left, and right covers open for a prolonged time.
- Return to the home screen after specifying settings in the menus.

The setting items for automatic maintenance are as follows.

Setting item	Contents	Setting value
[Cleaning When the Sub Power Turns On]	Set [Type] and [Frequency] for cleaning that is performed when the sub power is turned on. This prevents discharge issues during printing.	[Type] <ul style="list-style-type: none"> • [Normal Cleaning] • [Medium Cleaning] • [Powerful Cleaning] [Frequency] <ul style="list-style-type: none"> • [None] • [Periodically] 1 to 24 hours
[Cleaning before Printing Starts]	Set [Type] and [Frequency] for the cleaning that is performed at the start of printing. This prevents discharge issues during printing.	[Type] <ul style="list-style-type: none"> • [Normal Cleaning] • [Medium Cleaning] • [Powerful Cleaning] [Frequency] <ul style="list-style-type: none"> • [None] • [Periodically] 0.5 to 24 hours • [Each Time]
[Cleaning during Printing]	Set the [Type] and [Frequency] of cleaning to perform during printing. This prevents discharge issues during printing.	[Type] <ul style="list-style-type: none"> • [Normal Cleaning] • [Medium Cleaning] • [Powerful Cleaning] [Frequency] <ul style="list-style-type: none"> • [No Cleaning] • [Periodically] 0.5 to 24 hours
[Cleaning after Printing Finishes]	Set [Type] and [Frequency] for the cleaning that is performed when printing ends. This prevents the risk of malfunctions during standby and discharge issues at the next printing.	[Type] <ul style="list-style-type: none"> • [Normal Cleaning] • [Medium Cleaning] • [Powerful Cleaning] [Frequency] <ul style="list-style-type: none"> • [None] • [Periodically] 0.5 to 24 hours • [Each Time]
[Ink Circulation before Printing Starts]**1	Set [Frequency] for the ink circulation that is performed before the start of printing. This prevents uneven color issues caused by precipitation.	[Frequency]: <ul style="list-style-type: none"> • [None] • [Periodically] 0.5 to 24 hours • [Each Time]
[Ink Discharge before Printing Starts]**1	Set [Frequency] for the discharge of ink that cannot be mixed by ink circulation at the start of printing. This prevents uneven color issues caused by precipitation.	[Frequency] <ul style="list-style-type: none"> • [Disable] • [Enable]
[Periodic Ink Circulation]**1	Set [Frequency] for the ink circulation that is performed after the previous ink circulation. This prevents printer malfunctions caused by ink precipitation.	[Frequency] <ul style="list-style-type: none"> • [Periodically] 1 to 6 hours

Setting item	Contents	Setting value
[Periodic Cleaning]	Set [Type] and [Frequency] for the cleaning that is performed periodically. This prevents print head malfunction.	[Type] <ul style="list-style-type: none"> • [Normal Cleaning] • [Medium Cleaning] • [Powerful Cleaning] [Frequency] <ul style="list-style-type: none"> • [Periodically] 1 to 24 hours

*1 white ink only

IMPORTANT

If the automatic maintenance settings are configured without an adequate understanding, the maintenance results may not be as the customer wanted. Before configuring the automatic maintenance settings, be sure to contact your authorized dealer.

Measures When the Printer Is Not in Use for a Prolonged Period

Be sure to follow the instructions shown below when the printer is not in use for a prolonged period.

- **Empty the drain bottle.**

If you know that you will not use the machine for a prolonged period, empty the drain bottle. When the main power is on, the machine periodically performs automatic maintenance in which fluid is discharged.

The drain bottle is filled when the following periods elapse. To perform automatic maintenance, discard the discharged fluid during these periods.

- Approximately 2 weeks after the message [**When output, cleaning, and other operations are completed, discard the**] is displayed
- Approximately 150 days after the drain bottle is emptied

- **Do not allow the machine to run out of ink or cleaning liquid.**

The machine discharges ink and cleaning liquid during the automatic maintenance that is performed periodically. Install an ink cartridge and cleaning liquid pouch with sufficient remaining amount. The machine cannot perform automatic maintenance if it has run out of ink or cleaning liquid.

- **Switch the sub power on once every two weeks.**

Switch the sub power on once every 2 weeks. When you turn on the power, the machine automatically performs operations such as those to keep the print heads from drying out. Leaving the machine unused for a prolonged period may damage the print heads, so be sure to switch on the power to perform these automatic operations. Also, check for notifications and perform the required maintenance.

- **Keep the machine at a constant temperature and relative humidity.**

Even when the machine is not in use, keep it at a temperature of 5 to 40°C (41 to 104°F) and a relative humidity of 20 to 80% (with no condensation). Failure to do so may result in malfunction.

- **Do not leave the front, left, and right covers open for a prolonged time.**

This operation is necessary in order for the automatic maintenance function to perform operations to keep the print heads from drying out.

- **Return to the home screen after specifying settings in the menus.**

This operation is necessary in order for the automatic maintenance function to perform operations to keep the print heads from drying out.

RELATED LINKS

- [P. 315 If the Discharged Fluid Disposal Message Appears](#)

Regular Maintenance

Print Head Check before Printing	296
Performing a Printing Test	296
Cleaning the Machine	298
Cleaning the Media Path	298
Cleaning the Cutting Carriage Roller	299
Cleaning around the Print Heads	300
Manual Cleaning Method	301
Consumable Products and Parts Related to Manual Cleaning.....	312

Print Head Check before Printing

Performing a Printing Test

Before you carry out actual printing, perform a printing test to ensure no dot drop-out or dot displacement occurs. If dot drop-out or dot displacement occurs, perform cleaning of the print heads (normal cleaning).

MEMO

When performing printing tests successively, you can select **[Feed]** (vertical printing) or **[Scan]** (horizontal printing) as the printing position for the second and later tests in comparison to the first test.









[P. 266 Performing Printing Tests Arranged Horizontally](#)

Procedure

1. Set up the media.
2. Tap  **[Nozzle Drop-out Test]** on the home screen.
3. Tap **[Printing Test]>[Execute]**.
Printing of the test pattern starts.

MEMO

To change the start position for the printing test, configure the following settings.

1. Tap **[Output Start Location]>[Change]**.
2. Tap .
3. Tap     and move the cutter center to the position where you want to start cutting.
Tap  or  to move the media in the feed direction (forward-back). Tap  or  to move the cutting carriage in the scan direction (left-right).

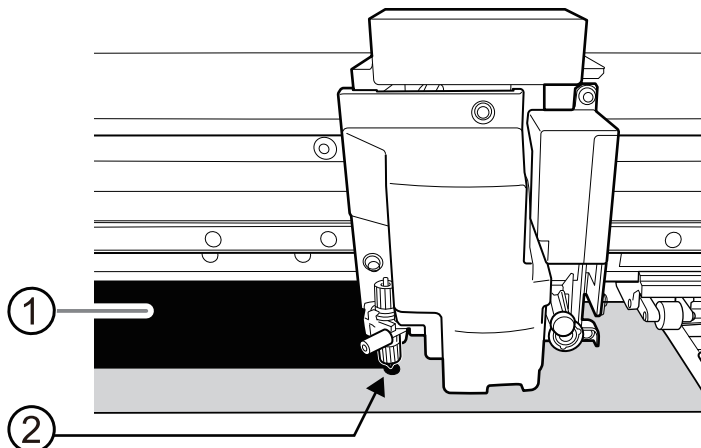

- ①: Printing area
 - ②: Base point (right edge of the printing area)
4. Once the position has been decided, tap **[Set Base Point Here]** to confirm it.
The base point position is updated.

4. Check whether there is dot drop-out or dot displacement in the test pattern.

Missing blocks indicate dot drop-out. Collapsed or inclined blocks indicate dot displacement.

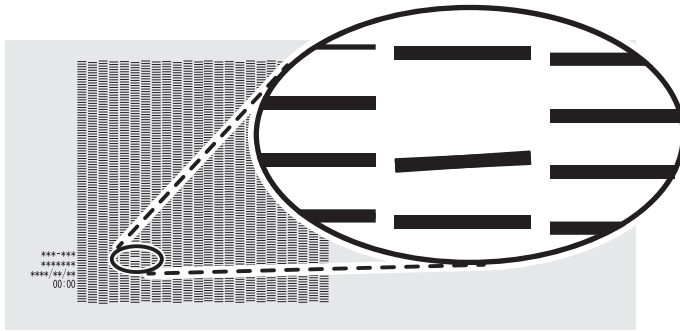

5. If you have opened the front cover, close it.

If no dot drop-out or dot displacement occurs, preparations for output are finished.

6. Tap  to return to the home screen.

RELATED LINKS

- [P. 318 When Dot Drop-out or Dot Displacement Occurs](#)

Cleaning the Machine

Cleaning the Media Path

Wipe away any ink or grime on the media path and other areas as part of the daily cleaning procedure. It is easy for ink or grime to affix to the media path, and, if left unattended, this will contaminate new media and have a negative effect on the transport of media when it is output. Pinch rollers, grit rollers, and the platen are particularly prone to the buildup of grime.

⚠ WARNING

Never use a solvent such as gasoline, alcohol, or thinner to perform cleaning.
Doing so may cause a fire.

⚠ CAUTION

Before attempting cleaning, switch off the sub power and wait until the platen and dryer cool (approximately 30 minutes).

Sudden movement of the machine may cause injury, or hot components may cause burns.

IMPORTANT

- This machine is a precision device and is sensitive to dust and dirt. Perform cleaning on a daily basis.
- Never attempt to oil or lubricate the machine.

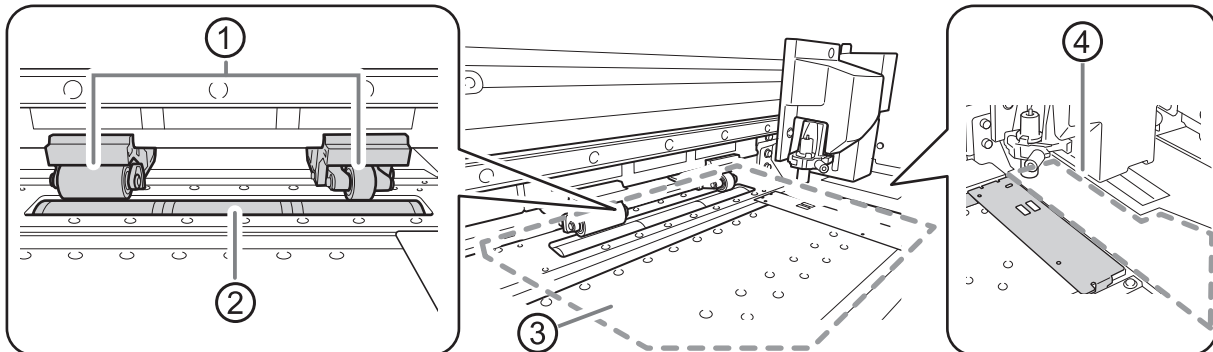

Clean by wiping with a cloth moistened with neutral detergent diluted with water then wrung dry.

①	Pinch roller	These are the positions where the media is fixed in place, so it is easy for ink and grime to affix to these positions. Failure to clean this part properly may result in the transfer of grime to the surface of media.
②	Grit roller	These are the positions where the media is transported, so it is easy for grime to affix to these positions. Remove buildup of media scraps and other material using a brush. Never use a metal brush.
③	Platen and media clamp	Wipe away any buildup of ink, grime, or cut media on the media path and in the grooves.
④	Near the flushing cover	Wipe off media cutting particles that were produced when the media was cut and scattered near the flushing cover.

Cleaning the Cutting Carriage Roller

Paper dust affixes to the separating knife carriage roller during media separation. Periodically wipe the area clean.

⚠ WARNING

Never use a solvent such as gasoline, alcohol, or thinner to perform cleaning.
Doing so may cause a fire.

⚠ CAUTION

Before attempting cleaning, switch off the sub power and wait until the platen and dryer cool (approximately 30 minutes).

Sudden movement of the machine may cause injury, or hot components may cause burns.

IMPORTANT

- This machine is a precision device and is sensitive to dust and dirt. Perform cleaning on a daily basis.
- Never attempt to oil or lubricate the machine.

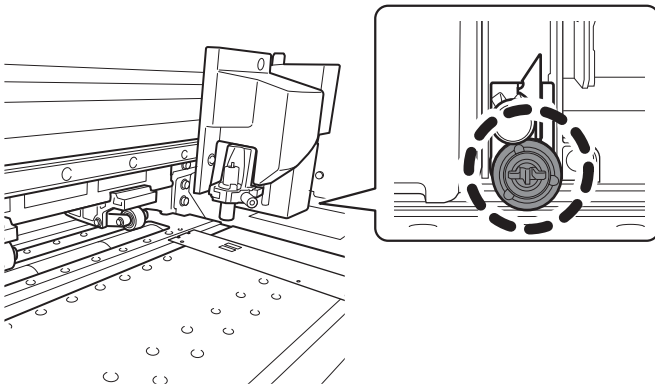

Clean by wiping with a cloth moistened with neutral detergent diluted with water then wrung dry.

Cleaning around the Print Heads

The print heads are important components that discharge ink. They require periodic and appropriate maintenance. Cleaning around the print heads is known as "manual cleaning." Be sure to perform manual cleaning in the following situations.

- When one of the following messages appears.

[The time for manual cleaning has arrived.]

[Maintenance must be performed.Perform manual cleaning.]

When the message appears, check the message details, and tap [OK].

Tap  on the home screen, and then tap the notification to display the manual cleaning menu screen.

- Before sending the print data if you want to perform unmanned printing at night.
- When symptoms that cannot be improved with powerful cleaning occur

When any of the symptoms given below occur and powerful cleaning is not effective, perform manual cleaning.

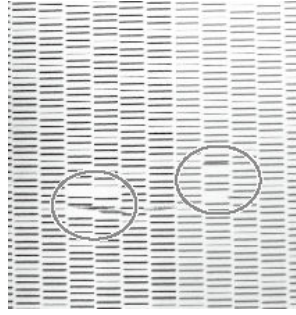
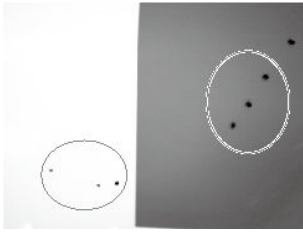
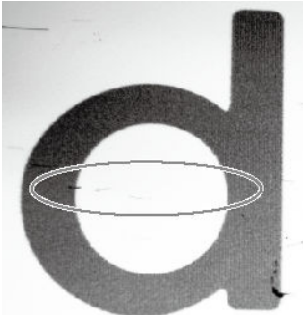
Dot drop-out/Dot displacement	Ink drips	Dragging dirt
		
<p>Dust or other foreign matter adheres to the print heads and impedes correct ink discharge.</p>	<p>Ink pools in dust or dirt adhered to the print heads, and drips onto the media.</p>	<p>The phenomenon where dirt or dust accumulates on the print heads.</p>

MEMO

Wiper replacement may also be effective in improving these symptoms.

RELATED LINKS

- [P. 337 Replacing the Wiper](#)

Manual Cleaning Method

⚠ WARNING

Be sure to perform operations as specified by the instructions, and never touch any area not specified in the instructions.

Sudden movement of the machine may cause injury or burns.



IMPORTANT

Important notes on this procedure

- Before attempting this operation, remove any media.
- To prevent the print heads from drying out, finish this procedure in 30 minutes or less. A warning beep sounds after 30 minutes.
- Never use any implements other than the included cleaning sticks. Cotton swabs or other lint-producing items may damage the print heads.
- Do not use a dropper or cleaning liquid other than those included.
- Be sure to use new cleaning sticks. Reusing cleaning sticks will adversely affect the printing results.
- Do not put a cleaning stick that has been used for cleaning into the cleaning liquid. Doing so will deteriorate the cleaning liquid.
- Never rub the print head surface (nozzle surface).
- Stroke the sponges very gently, applying as little pressure as possible. Never rub, scrape, or crush them.
- If you use up the cleaning sticks or cleaning liquid, contact your authorized dealer or visit our website (<https://www.rolanddg.co.jp/>).
- Prepare your own cleaning sheets for wiping off ink.

If a warning beep sounds during cleaning

- A warning beep sounds 30 minutes after operation starts. Stop work, close all the covers, and then press [Finish All] to end the manual cleaning mode. After that, restart the procedure from the beginning.

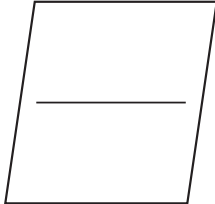
Required items			
			
Cleaning stick	Dropper	Cleaning liquid	Cleaning sheets



1. Cleaning the Print Head Caps

Procedure

1. Remove any media.
2. Tap .
3. Tap [Cleaning]>[Manual Cleaning].
4. Tap [Execute].
5. Tap [OK].
The print head carriage moves to the left end of the machine.
6. Open the right cover.

MEMO

The procedure is displayed on the operation panel.

- Tap  or  to check the procedure.
- If you complete the work without viewing the instructions, tap [Finish All].

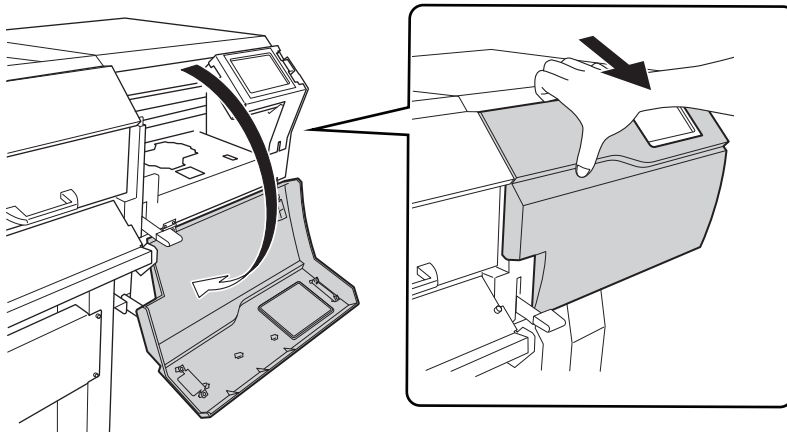

7. Open the left cover.

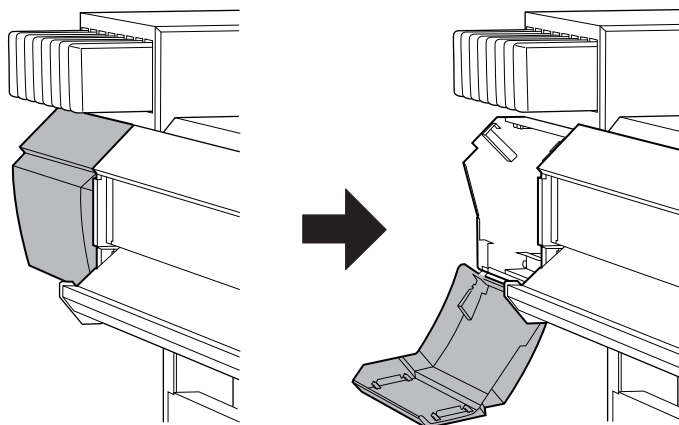

8. Touch the location shown in the figure to discharge any static electricity.

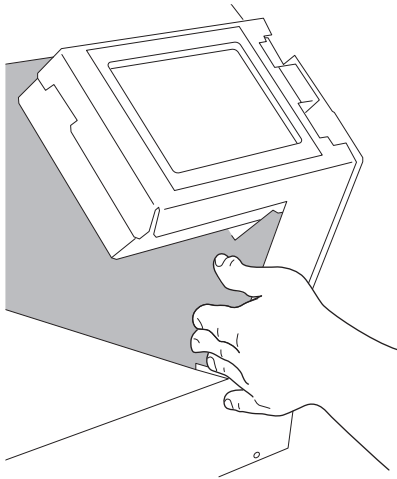

9. Moisten a new cleaning stick with the cleaning liquid.

MEMO

- Be sure to use one of the included cleaning sticks.
- Do not use a previously used cleaning stick.
- Do not put a previously used cleaning stick into the cleaning liquid.

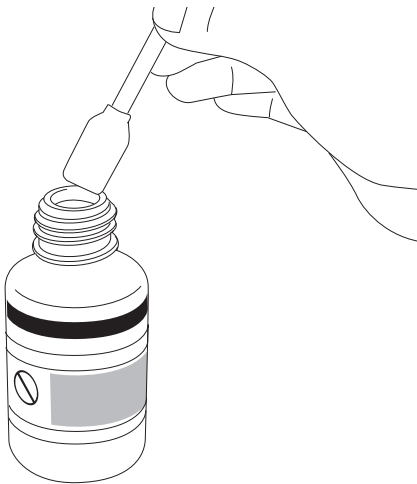

10. Clean the locations shown in the following figure.

Be especially careful to clean away any fibrous dust (lint).

- (1) Wipe off wiper surfaces a and b with the cleaning stick.
- (2) Wipe off the area in the figure with a cleaning stick.
- (3) Use the wide surface of the cleaning stick, pressing the cleaning stick down while sliding between locations to clean up dirt.

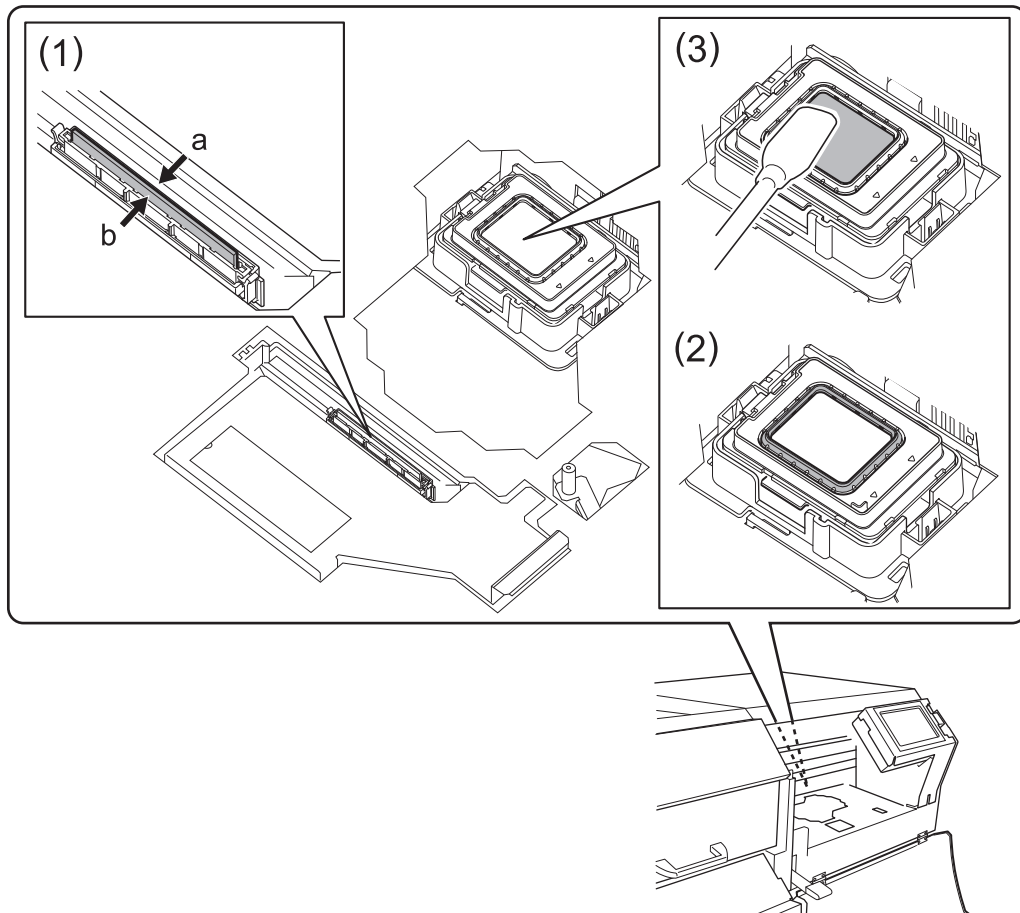

11. Grasping the part indicated by ①, open the flushing cover.

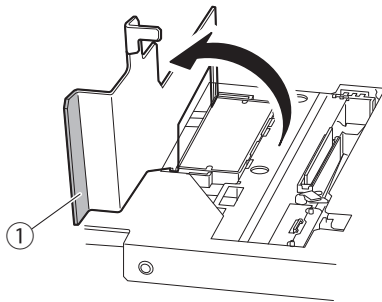

12. Suction out some cleaning liquid with the dropper, and then drip this cleaning liquid in the location indicated in the following figure.

Use the included dropper.

Firmly squeezing the dropper and suctioning out the cleaning liquid (①) fills the dropper with enough cleaning liquid for one location.

Drip the cleaning liquid evenly and uniformly on the flushing sponge (②).

IMPORTANT

- A low amount of cleaning liquid in this location may lead to poor printing quality.
- When dripping the cleaning liquid, ensure that the tip of the dropper does not come into contact with the locations.

If it does, wipe away any dirt from the tip of the dropper before the next time you suction out cleaning liquid.

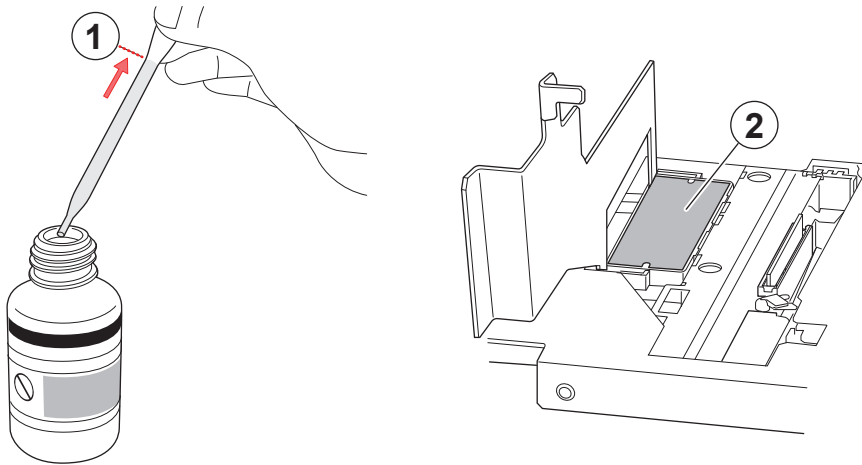

13. Close the flushing cover.

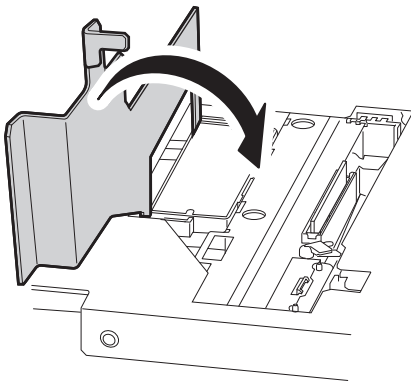

14. Remove any ink adhering to the area around the flushing sponge and print head cap.

- (1) Moisten a new cleaning stick with the cleaning liquid.
- (2) Wipe off any ink with a cleaning stick.
- (3) Wipe off any cleaning liquid remaining on the machine with a cleaning sheet.
- (4) Discard the cleaning stick and cleaning sheet.

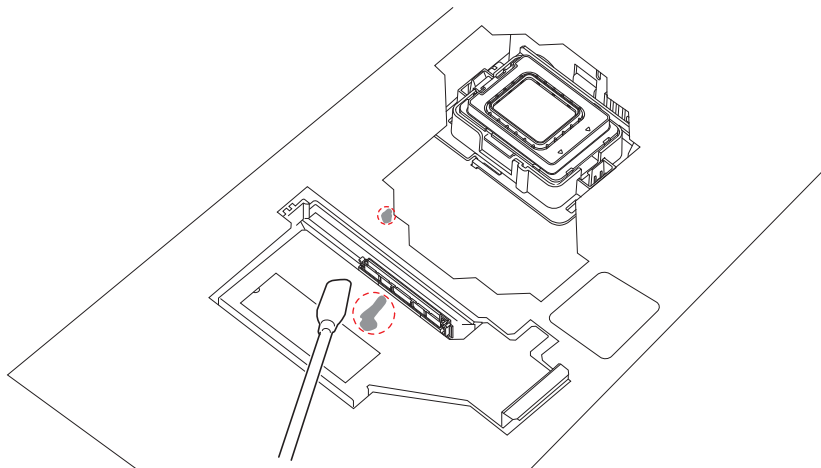

15. Close the right cover.

2. Cleaning the Print Heads

Procedure

1. Moisten a new cleaning stick with the cleaning liquid.

IMPORTANT

1. Be sure to use one of the included cleaning sticks.
2. Do not use a previously used cleaning stick.
3. Do not put a previously used cleaning stick into the cleaning liquid.

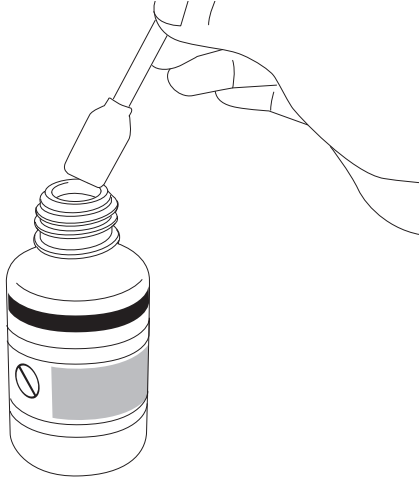

2. Use the wide surface of the cleaning stick to wipe away any dirt from the locations shown in the following figure.

Be especially careful to clean away any fibrous dust (lint). Also wipe with the opposite, clean surface, ensuring that dirt from the dirty surface does not adhere to the head.

- Print heads

IMPORTANT

Be careful not to wipe off the grooves on the print head surface (①).

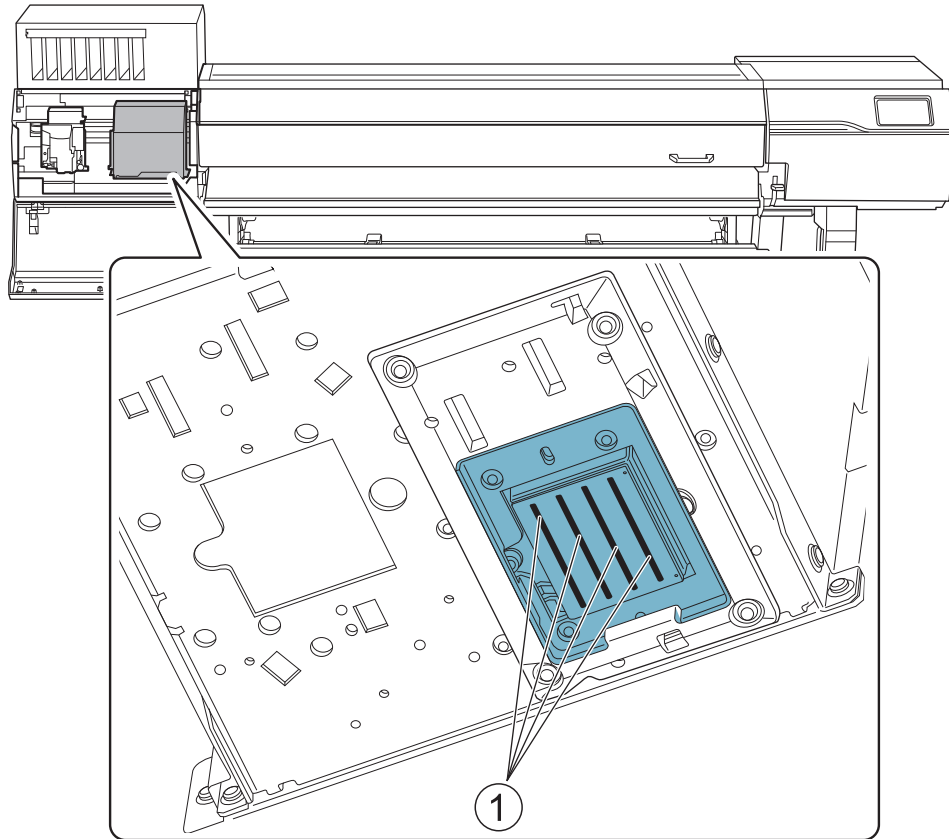

- Edges and sides of the print head (②)

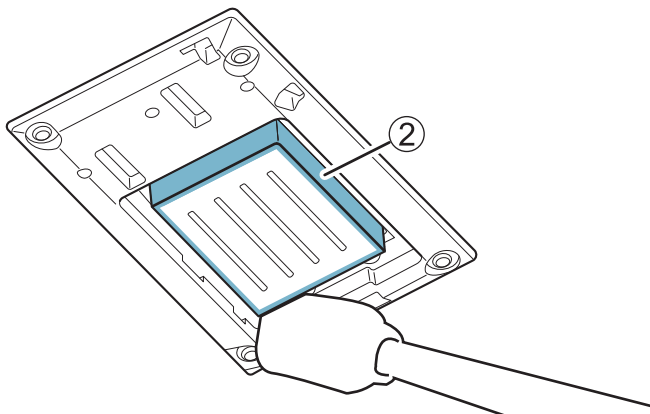

- Around the print head
If this area has any ink or cleaning liquid that appears likely to drip, use a dry cloth that is not fluffy to gently wipe away the ink or cleaning liquid.

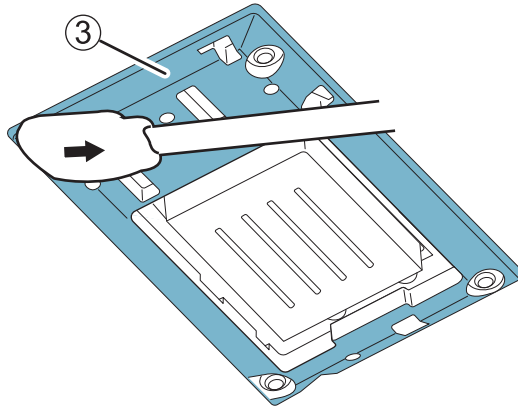

3. Close the left cover.

4. Tap [Finish All].

Cleaning will start. The details of the operation in progress and the (approximate) remaining time of that work are displayed in the status bar at the top of the screen. When the work is finished, the status bar returns to its original display.

5. Tap  to return to the home screen.

3. Performing a Printing Test to Check the Results

Before you carry out actual printing, perform a printing test to ensure no dot drop-out or dot displacement occurs. If dot drop-out or dot displacement occurs, perform cleaning of the print heads (normal cleaning).

MEMO

When performing printing tests successively, you can select [Feed] (vertical printing) or [Scan] (horizontal printing) as the printing position for the second and later tests in comparison to the first test.









[P. 266 Performing Printing Tests Arranged Horizontally](#)

Procedure

1. Set up the media.
2. Tap  [Nozzle Drop-out Test] on the home screen.
3. Tap [Printing Test]>[Execute].
Printing of the test pattern starts.

MEMO

To change the start position for the printing test, configure the following settings.

1. Tap [Output Start Location]>[Change].
2. Tap  .
The cutting carriage moves to the current base point.
3. Tap     and move the cutter center to the position where you want to start cutting.
Tap  or  to move the media in the feed direction (forward-back). Tap  or  to move the cutting carriage in the scan direction (left-right).

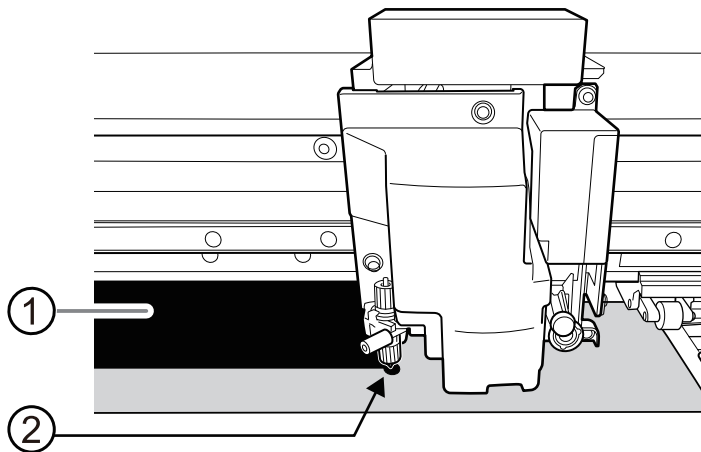

- ①: Printing area
 - ②: Base point (right edge of the printing area)
4. Once the position has been decided, tap [Set Base Point Here] to confirm it.
The base point position is updated.

4. Check whether there is dot drop-out or dot displacement in the test pattern.
Missing blocks indicate dot drop-out. Collapsed or inclined blocks indicate dot displacement.

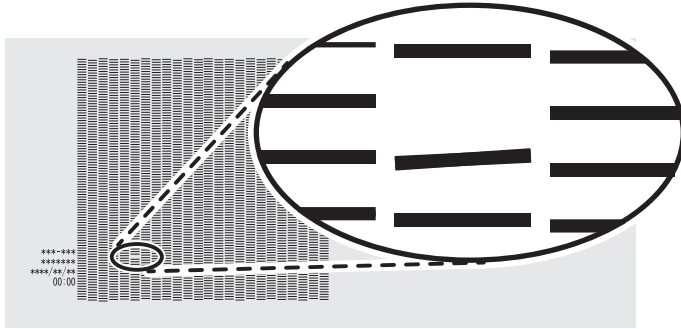

5. If you have opened the front cover, close it.
If no dot drop-out or dot displacement occurs, preparations for output are finished.
6. Tap  to return to the home screen.

RELATED LINKS

- [P. 318 When Dot Drop-out or Dot Displacement Occurs](#)

Consumable Products and Parts Related to Manual Cleaning

The cleaning sticks, cleaning liquid, and print heads are consumable products or consumable parts.

- If you use up the cleaning sticks and cleaning liquid used for manual cleaning, contact your authorized Roland DG Corporation dealer or visit our website (<https://www.rolanddg.co.jp/>).
- The print heads are components that wear out. Periodic replacement is required, with the frequency of replacement depending on use. Contact your authorized Roland DG Corporation dealer.

Disposing of Discharged Fluid

Precautions for Disposing of Discharged Fluid	314
If the Discharged Fluid Disposal Message Appears.....	315

Precautions for Disposing of Discharged Fluid

⚠ WARNING

Never place discharged fluid or ink near an open flame.

Doing so may cause a fire.

⚠ CAUTION

To store discharged fluid temporarily, place it in the included drain bottle or in a durable sealed container such as a metal can or polyethylene tank, and cap the container tightly.

Any spillage or vapor leakage may cause fire, odor, or physical distress.

IMPORTANT

Dispose of discharged fluid properly, in accordance with the laws in effect in your locale.

Discharged fluid is flammable and contains toxic ingredients. Never attempt to incinerate discharged fluid or discard it with ordinary trash. Also, do not dispose of it in sewer systems, rivers, or streams. Doing so may have an adverse impact on the environment.

IMPORTANT

Do not store discharged fluid in a location where it is exposed to direct sunlight.

When temporarily storing discharged fluid in the included drain bottle, do not store it in a location that is exposed to direct sunlight. The discharged fluid may harden, making the drain bottle unusable. The drain bottle may also deteriorate, leading to discharged fluid leaks.

If the Discharged Fluid Disposal Message Appears

The message [When output, cleaning, and other operations are completed, discard the] appears when a certain amount of discharged fluid has collected in the bottle. If this message appears, dispose of the discharged fluid.

Procedure

1. When the message [When output, cleaning, and other operations are completed, discard the] appears, tap [OK].
2. Tap  to display the notification.
3. Tap the following notification.

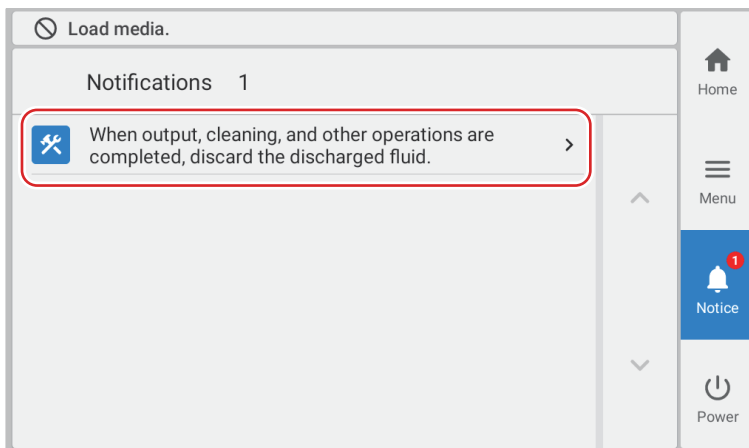

The [Drain Bottle] screen appears.

MEMO

You can dispose of discharged fluid even if the above message has not appeared. Use the following operations to display the drain bottle screen, and then dispose of discharged fluid according to the procedure starting from step 4.

1. Tap .
2. Tap [Maintenance]>[Drain Bottle].

4. Tap [Execute].
5. Tap [OK].
6. Remove the drain bottle and discard the discharged fluid.

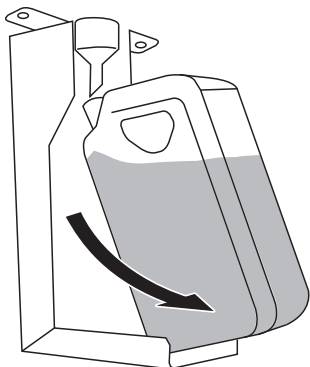

CAUTION

Before you detach the drain bottle, be sure to wait for the screen to display [Discard the discharged fluid in the bottle.]. After discarding the discharged fluid, promptly attach the drain bottle to the machine.

Failing to follow this procedure may cause discharged fluid to flow out of the tube and spill, soiling your hands or the floor.

IMPORTANT

When you remove the drain bottle, a few drops of discharged fluid may come out of the machine. Exercise caution to prevent this fluid from soiling your hands or the floor.

7. Quickly attach the emptied drain bottle to the machine once more.
8. Tap [Finish].
The display returns to the original window.
9. Tap  to return to the home screen.

Advanced Maintenance

When Dot Drop-out or Dot Displacement Occurs	318
Normal Cleaning Method	318
When Normal Cleaning Is Not Effective	320
Medium Cleaning Method	320
Powerful Cleaning Method	322
If Colors Are Uneven	324
Light Choke Cleaning Method	324
Ink Circulating Method	326
Handling Severe Dot Drop-out and Dot Displacement	327
Ink Renewal Method	327
Partially Restricting the Print Heads Used for Printing	330
Emergency Measure) Cleaning the Print Head Surface	332
When the Operation Panel Is Dirty	335
Operation Panel Cleaning Method	335

When Dot Drop-out or Dot Displacement Occurs

If dot drop-out or dot displacement occurs, perform cleaning of the print heads (normal cleaning).

Normal Cleaning Method

MEMO

If the media has already been set up, the [After cleaning, perform a printing test.] menu appears on the [Normal Cleaning] screen. When this setting is turned on, a printing test is performed after cleaning.

Procedure

1. Set up the media.

2. Tap .

3. Tap [Cleaning]>[Normal Cleaning].

The screen shown below appears.

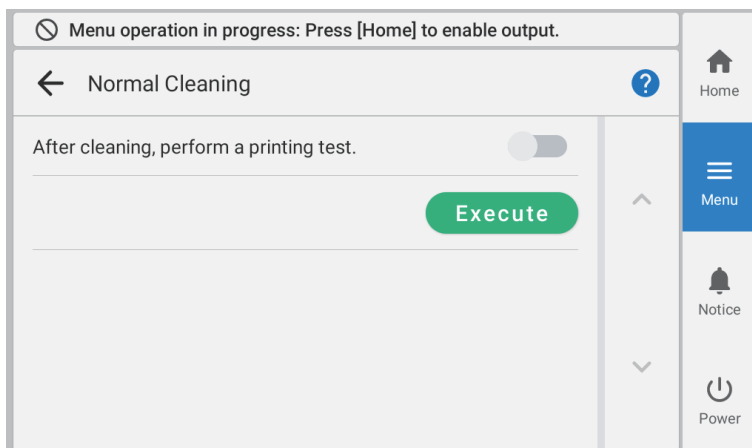

4. Tap [Execute].

Cleaning will start. The details of the operation in progress and the (approximate) remaining time of that work are displayed in the status bar at the top of the screen. When the work is finished, the status bar returns to its original display.

5. Tap .

6. Tap [Printing Test].

7. Tap [Nozzle Drop-out Test]>[Execute].

8. Check to make sure the dot drop-out or dot displacement has been corrected.

If the problem persists, try performing normal cleaning again. If the printer has been used for a long period, dot drop-outs may not be fixed even after performing normal cleaning two or three times. If this is the case, clean using a different method.

9. Tap  to return to the home screen.

RELATED LINKS

- [P. 320 When Normal Cleaning Is Not Effective](#)

When Normal Cleaning Is Not Effective

Medium Cleaning Method

The print heads are important components that discharge ink. They require periodic and appropriate maintenance. When problems such as dot drop-out are not resolved by performing normal cleaning 2 to 3 times, perform the more forceful “medium cleaning” to remove clogging from the print heads.

IMPORTANT

Medium cleaning consumes more ink than normal cleaning, and overly frequent use may damage the print heads themselves. Avoid performing this operation more than necessary.

MEMO

If the media has already been set up, the [After cleaning, perform a printing test.] menu appears on the [Medium Cleaning] screen. When this setting is turned on, a printing test is performed after cleaning.

Procedure

1. Set up the media.
2. Tap .
3. Tap [Cleaning]>[Medium Cleaning].
The screen shown below appears.

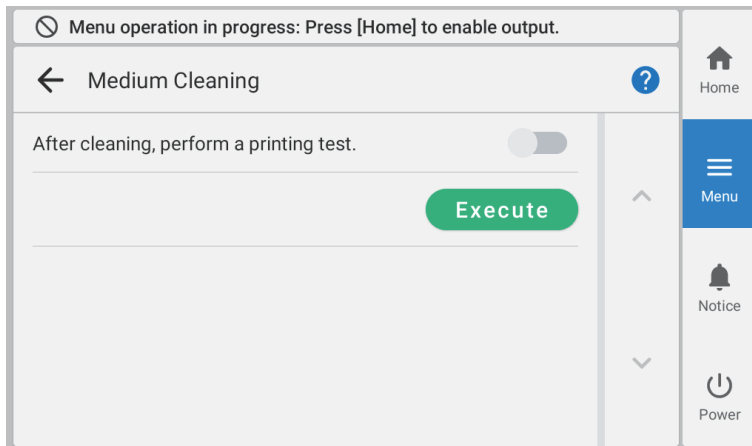

4. Tap [Execute].
Cleaning will start. The details of the operation in progress and the (approximate) remaining time of that work are displayed in the status bar at the top of the screen. When the work is finished, the status bar returns to its original display.
5. Tap .
6. Tap [Printing Test].
7. Select [Nozzle Drop-out Test] and tap [Execute].
Perform a printing test again to check whether the dot drop-out and dot displacement have been corrected.

MEMO

- If the problem persists, try performing medium cleaning again.
- If problems such as dot drop-out and dot displacement persist even after you have performed medium cleaning several times, perform "powerful cleaning."

8. Tap  to return to the home screen.

RELATED LINKS

- [P. 322 Powerful Cleaning Method](#)

Powerful Cleaning Method

The print heads are important components that discharge ink. They require periodic and appropriate maintenance. When problems such as dot drop-out are not resolved by medium cleaning, perform the more forceful "powerful cleaning" to remove clogging from the print heads.

IMPORTANT

Powerful cleaning consumes more ink than medium cleaning, and overly frequent use may damage the print heads themselves. Avoid performing this operation more than necessary.

MEMO

If the media has already been set up, the [After cleaning, perform a printing test.] menu appears on the [Powerful Cleaning] screen. When this setting is turned on, a printing test is performed after cleaning.

Procedure

1. Set up the media.
2. Tap .
3. Tap [Cleaning]>[Powerful Cleaning].
The screen shown below appears.

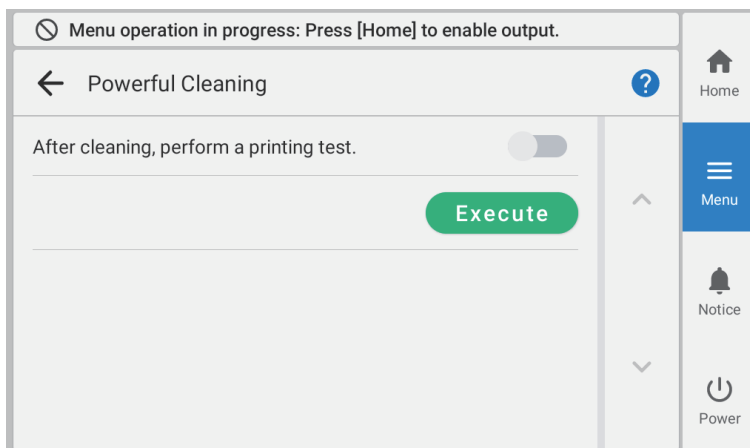

4. Tap [Execute].
Cleaning will start. The details of the operation in progress and the (approximate) remaining time of that work are displayed in the status bar at the top of the screen. When the work is finished, the status bar returns to its original display.
5. Tap .
6. Tap [Printing Test].
7. Select [Nozzle Drop-out Test] and tap [Execute].
Perform a printing test again to check whether the dot drop-out and dot displacement have been corrected.

MEMO

- If the problem persists, try performing powerful cleaning again.
- If problems such as dot drop-out and dot displacement persist even after you have performed powerful cleaning several times, perform "manual cleaning."

8. Tap  to return to the home screen.

RELATED LINKS

- [P. 301 Manual Cleaning Method](#)

If Colors Are Uneven

If Uneven Color Issues Occur with Ink Other than White Ink

Perform the following operations.

1. Shake the ink cartridge to mix the ink.
[P. 129 Preventing Sedimentation in Inks](#)
2. If the uneven color issue is not improved after performing Step 1, perform [Light Choke Cleaning].
[P. 324 Light Choke Cleaning Method](#)
3. If the uneven color issue is not improved after performing Step 2, perform [Ink Renewal].
[P. 327 Ink Renewal Method](#)
4. If the uneven color issue is not improved after performing the above work, contact your authorized dealer.

If Uneven Color Issues Occur with White Ink

Perform the following operations.

1. Shake the ink cartridge to mix the ink.
[P. 129 Preventing Sedimentation in Inks](#)
2. If the uneven color issue is not improved after performing Step 1, perform [Ink Circulation].
[P. 326 Ink Circulating Method](#)
3. If the uneven color issue is not improved after performing Step 2, perform [Light Choke Cleaning].
[P. 324 Light Choke Cleaning Method](#)
4. If the uneven color issue is not improved after performing Step 3, perform [Ink Renewal].
[P. 327 Ink Renewal Method](#)
5. If the uneven color issue is not improved after performing the above work, contact your authorized dealer.

Light Choke Cleaning Method

This will stabilize the output colors by agitating the ink.

Perform this operation when uneven color issues (except for white ink) are not resolved after performing the work below.

- Ink mixing

Perform this operation when uneven color issues (white ink) are not resolved after performing the work below.

- Ink mixing
- [Ink Circulation]

IMPORTANT

Light choke cleaning consumes a lot of ink, and overly frequent use may damage the print heads themselves. Avoid performing this operation more than necessary.

Procedure

1. Tap .
2. Tap [Maintenance]>[Light Choke Cleaning].
3. Tap [Execute].

Cleaning will start. The details of the operation in progress and the (approximate) remaining time of that work are displayed in the status bar at the top of the screen. When the work is finished, the status bar returns to its original display.

MEMO

If [Discard the discharged fluid in the bottle.] appears after tapping [Execute]

1. Remove the drain bottle and discard the discharged fluid.

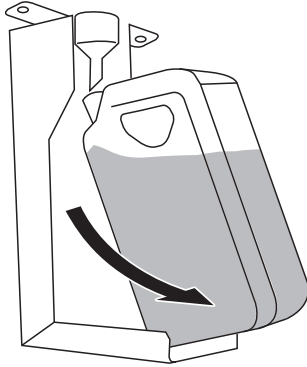

2. Quickly attach the emptied drain bottle to the machine once more.
3. Tap [Finish].

⚠ WARNING

Never place discharged fluid or ink near an open flame.

Doing so may cause a fire.

⚠ CAUTION

Before you detach the drain bottle, be sure to wait for the screen to display [Discard the discharged fluid in the bottle.]. After discarding the discharged fluid, promptly attach the drain bottle to the machine.

Failing to follow this procedure may cause discharged fluid to flow out of the tube and spill, soiling your hands or the floor.

⚠ CAUTION

To store discharged fluid temporarily, place it in the included drain bottle or in a durable sealed container such as a metal can or polyethylene tank, and cap the container tightly.

Any spillage or vapor leakage may cause fire, odor, or physical distress.

IMPORTANT

- When you remove the drain bottle, a few drops of discharged fluid may come out of the machine. Exercise caution to prevent this fluid from soiling your hands or the floor.
- Dispose of discharged fluid properly, in accordance with the laws in effect in your locale.
- Discharged fluid is flammable and contains toxic ingredients. Never attempt to incinerate discharged fluid or discard it with ordinary trash. Also, do not dispose of it in sewer systems, rivers, or streams. Doing so may have an adverse impact on the environment.

4. Tap  to return to the home screen.

RELATED LINKS

- [P. 327 Ink Renewal Method](#)

Ink Circulating Method



If uneven color issues with white ink are not resolved even after shaking the ink cartridges to mix the ink, perform [Ink Circulation].

Uneven colors refers to the symptom of printed colors being uneven (such as the color density being inconsistent) even when the same data is printed with the same settings.

MEMO

If the media has already been set up, the [After ink circulation, perform a printing test.] menu appears on the [Ink Circulation] screen. When this setting is turned on, a printing test is performed after ink circulation.

Procedure

1. Tap .
2. Tap [Maintenance]>[Ink Circulation].
The [Ink Circulation] window appears.
3. Tap [Execute].
Ink circulation starts. The details of the operation in progress and the (approximate) remaining time of that work are displayed in the status bar at the top of the screen. When the work is finished, the status bar returns to its original display.
4. Tap  to return to the home screen.

Handling Severe Dot Drop-out and Dot Displacement

If the position of the dot drop-out or dot displacement changes at each printing test

Perform the following operations.

1. Perform [Normal Cleaning] 2 to 3 times.
P. 318 Normal Cleaning Method
2. Perform [Medium Cleaning].
P. 320 Medium Cleaning Method
3. Perform [Powerful Cleaning].
P. 322 Powerful Cleaning Method
4. Perform [Manual Cleaning].
P. 301 Manual Cleaning Method
5. Perform [Ink Renewal].
P. 327 Ink Renewal Method
6. Perform [Medium Cleaning] 2 to 3 times.
P. 320 Medium Cleaning Method
7. If the dot drop-out or dot displacement is not corrected after performing the above work, contact your authorized dealer.

If the position of the dot drop-out or dot displacement does not change at each printing test

Perform the following operations.

1. Perform [Normal Cleaning] 2 to 3 times.
P. 318 Normal Cleaning Method
2. Perform [Medium Cleaning].
P. 320 Medium Cleaning Method
3. Perform [Powerful Cleaning].
P. 322 Powerful Cleaning Method
4. Perform [Manual Cleaning].
P. 301 Manual Cleaning Method
5. Perform [Ink Renewal].
P. 327 Ink Renewal Method
6. If the dot drop-out or dot displacement is not corrected after performing the above work, contact your authorized dealer.

Ink Renewal Method

Perform this operation when ink discharge issues are not resolved after performing the work below.

- [Normal Cleaning]
- [Medium Cleaning]
- [Powerful Cleaning]
- [Manual Cleaning]

Perform this operation when uneven color issues (except for white ink) are not resolved after performing the work below.

- Ink mixing
- [Light Choke Cleaning]

Perform this operation when uneven color issues (white ink) are not resolved after performing the work below.

- Ink mixing
- [Ink Circulation]
- [Light Choke Cleaning]

IMPORTANT

A large amount of ink will be discharged during this operation. Perform only when discharge issues and uneven color issues are not resolved after performing the above work.

Procedure

1. Tap .
2. Tap [Maintenance]>[Ink Renewal].
The screen shown below appears.

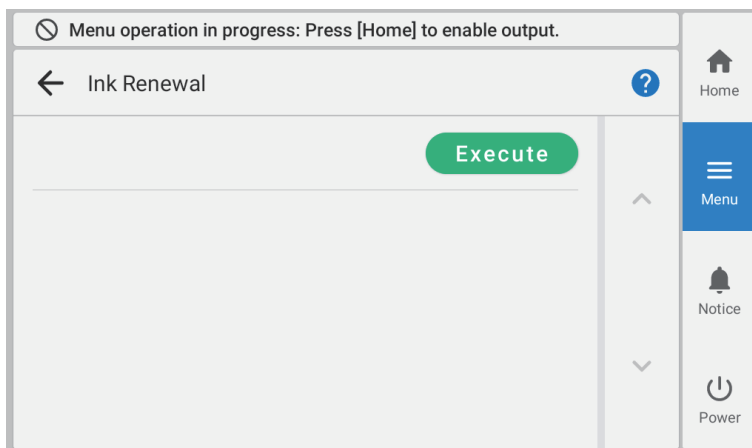

3. Tap [Execute].
Cleaning will start. The details of the operation in progress and the (approximate) remaining time of that work are displayed in the status bar at the top of the screen. When the work is finished, the status bar returns to its original display.

MEMO

If [Discard the discharged fluid in the bottle.] appears after tapping [Execute]

1. Remove the drain bottle and discard the discharged fluid.



2. Quickly attach the emptied drain bottle to the machine once more.

3. Tap [Finish].

⚠ WARNING

Never place discharged fluid or ink near an open flame.
Doing so may cause a fire.

⚠ CAUTION

Before you detach the drain bottle, be sure to wait for the screen to display [Discard the discharged fluid in the bottle.]. After discarding the discharged fluid, promptly attach the drain bottle to the machine.

Failing to follow this procedure may cause discharged fluid to flow out of the tube and spill, soiling your hands or the floor.

⚠ CAUTION

To store discharged fluid temporarily, place it in the included drain bottle or in a durable sealed container such as a metal can or polyethylene tank, and cap the container tightly.
Any spillage or vapor leakage may cause fire, odor, or physical distress.

IMPORTANT

- When you remove the drain bottle, a few drops of discharged fluid may come out of the machine. Exercise caution to prevent this fluid from soiling your hands or the floor.
- Dispose of discharged fluid properly, in accordance with the laws in effect in your locale.
- Discharged fluid is flammable and contains toxic ingredients. Never attempt to incinerate discharged fluid or discard it with ordinary trash. Also, do not dispose of it in sewer systems, rivers, or streams. Doing so may have an adverse impact on the environment.

4. Tap  to return to the home screen.

RELATED LINKS

- [P. 129 Preventing Sedimentation in Inks](#)
- [P. 301 Manual Cleaning Method](#)
- [P. 318 When Dot Drop-out or Dot Displacement Occurs](#)
- [P. 320 Medium Cleaning Method](#)
- [P. 322 Powerful Cleaning Method](#)
- [P. 324 Light Choke Cleaning Method](#)
- [P. 326 Ink Circulating Method](#)

Partially Restricting the Print Heads Used for Printing

When dot drop-out or dot displacement is not improved even after renewing the ink, partially restrict the print heads to use for printing (i.e. prevent the use of the print heads that are causing discharge issues). This operation is called the "nozzle mask," and while it slows down printing speed, it also allows you to decrease the impact of dot drop-out or dot displacement.

First print a test pattern, and then select the nozzle group to use by viewing the test results. After that, use VersaWorks to select the nozzle group used for printing.

1. Performing a Printing Test for the Nozzle Mask

Procedure

1. Set up the media.
2. Tap .
3. Tap [Cleaning]>[Printing Test].
4. Select [Nozzle Mask Test] and tap [Execute].
Printing of the test pattern starts.
5. Check for dot drop-out and dot displacement by viewing the results of the printing test.

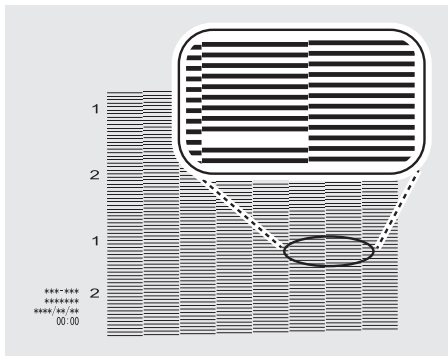

MEMO

If the printing-test results are difficult to interpret

Check the results in a bright location, changing your line of vision. They are visible using the reflection of the light.

6. If you have opened the front cover, close it.
7. Tap  to return to the home screen.

2. Limiting Print Heads Used for Printing: [Nozzle Mask]

Use VersaWorks to select the nozzle group used for printing. For the detailed procedure, see the VersaWorks Master Guide.

[VersaWorks manual](#)

Emergency Measure) Cleaning the Print Head Surface

When dot drop-out or dot deflection is not improved even if cleaning is performed several times, you can clean the surface of the print heads as an emergency measure. The print head surface (nozzle surface) is a very delicate mechanism, so work must be performed carefully and cautiously.

This operation is an emergency measure. It may damage defect-free parts depending on the symptoms, worsening the symptoms. If you have any questions, contact your authorized dealer.

⚠ WARNING

Be sure to perform operations as specified by the instructions, and never touch any area not specified in the instructions.

Sudden movement of the machine may cause injury or burns.



IMPORTANT

Important notes on this procedure

- Before attempting this operation, remove any media.
- To prevent the print heads from drying out, finish this procedure in 30 minutes or less. A warning beep sounds after 30 minutes.
- Never use any implements other than the included cleaning sticks. Cotton swabs or other lint-producing items may damage the print heads.
- Do not use a dropper or cleaning liquid other than those included.
- Be sure to use new cleaning sticks. Reusing cleaning sticks will adversely affect the printing results.
- Do not put a cleaning stick that has been used for cleaning into the cleaning liquid. Doing so will deteriorate the cleaning liquid.
- Never rub the print head surface (nozzle surface).
- If you use up the cleaning sticks or cleaning liquid, contact your authorized dealer or visit our website (<https://www.rolanddg.co.jp/>).

If a warning beep sounds during cleaning

- A warning beep sounds 30 minutes after operation starts. Stop work, close all the covers, and then press [Finish All] to end the manual cleaning mode. After that, restart the procedure from the beginning.

Required items	
	
Cleaning stick	Cleaning liquid

Procedure

1. Remove any media.
2. Tap .
3. Tap [Cleaning]>[Manual Cleaning].
4. Tap [Execute].
5. Tap [OK].
The print head carriage moves to the left end of the machine.

The following procedure explains the procedure for emergency measures. Be aware that the procedure is different from ordinary manual cleaning.

6. Open the left cover.

MEMO

The procedure is displayed on the operation panel.

- Tap **<** or **>** to check the procedure.
- If you complete the work without viewing the instructions, tap **[Finish All]**.

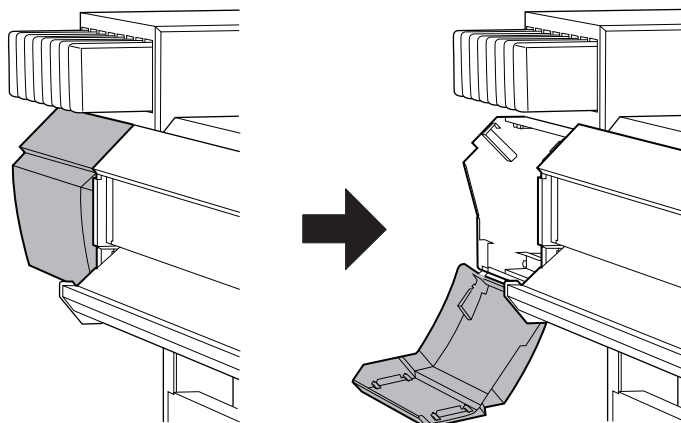

7. Moisten a new cleaning stick with the cleaning liquid.

IMPORTANT

- Be sure to use one of the included cleaning sticks.
- Do not use a previously used cleaning stick.
- Do not put a previously used cleaning stick into the cleaning liquid.

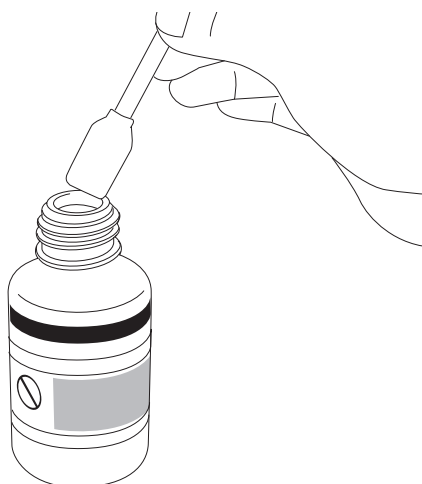

8. Very gently touch the cleaning stick against the print head surface (nozzle surface).

Very softly press the cleaning stick against the print head so that cleaning liquid soaks into the print head surface (nozzle surface). Never rub the stick on the surface or press it forcibly.

IMPORTANT

Primarily push the cleaning stick into the grooves on the print head surface ①.

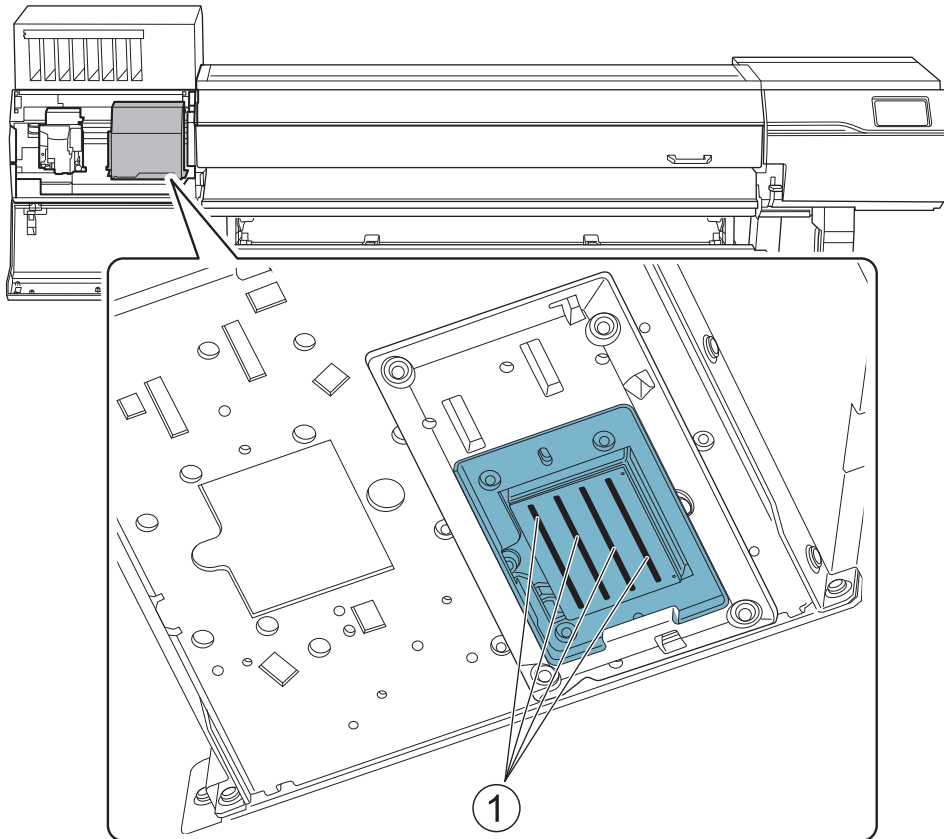

9. Close the left cover.

10. Tap [Finish All].

Cleaning will start. The details of the operation in progress and the (approximate) remaining time of that work are displayed in the status bar at the top of the screen. When the work is finished, the status bar returns to its original display.

11. Tap  to return to the home screen.

When the Operation Panel Is Dirty

Operation Panel Cleaning Method

IMPORTANT

Important notes on this procedure

- The cloths, alcohol, and similar items used in cleaning are not included with the product.
- Put on gloves before cleaning the operation panel. Also, be sure to use a cloth. Liquid entering into the operation panel through its gaps may cause printer malfunctions.

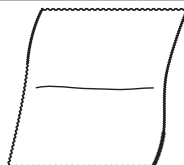
Required items	
	
Anhydrous ethanol or isopropyl alcohol	Cloth (that is not fluffy)

⚠ CAUTION

When using anhydrous ethanol or isopropyl alcohol, be sure to follow the product's usage precautions.

Exercise caution regarding items such as fire, ventilation, and skin irritation.

⚠ CAUTION

Only use anhydrous ethanol or isopropyl alcohol.

Using chemicals (or similar substances) other than anhydrous ethanol or isopropyl alcohol may lead to operation panel damage.

Procedure

1. Turn off the sub power followed by the main power.
2. Wipe off the operation panel with a cloth soaked in anhydrous ethanol or isopropyl alcohol.
Wipe slowly and gently to remove the grime.
3. Turn on the main power switch.

Replacing Consumable Parts

Replacing Parts for Maintenance	337
Replacing the Wiper	337
Replacing the Wiper Cleaner	340
Replacing the Print Head Caps	342
Replacing the Flushing Sponges	344
Replacing the Blade/Separating Knife.....	346
Replacing the Blade.....	346
Replacing the Separating Knife	352
Inquiries for Consumable Parts and Products	354
Items That You Can Purchase or Perform by Yourself.....	354
Items That Require Inquiries before Replacement	354

Replacing Parts for Maintenance

Replacing the Wiper

The wiper periodically cleans the surface of the print heads.



Replacement is necessary if the [The time for wiper replacement has arrived.] message appears.

For information about purchasing wipers, contact your authorized dealer or visit our website (<https://www.rolanddg.co.jp/>).

⚠ WARNING

Be sure to perform operations as specified by the instructions, and never touch any area not specified in the instructions.

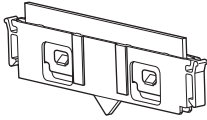
Sudden movement of the machine may cause injury or burns.

Required items		
		
Wiper	Cleaning stick	Cleaning liquid

IMPORTANT

- To prevent the print heads from drying out, finish this procedure in 10 minutes or less. A warning beep sounds after 10 minutes.
- Take care to prevent ink from adhering to the operation panel.

Procedure

1. When the message [The time for wiper replacement has arrived.] appears, tap [OK].
2. Remove any media.
3. Tap  to display the messages.
4. Tap [The time for wiper replacement has arrived.].

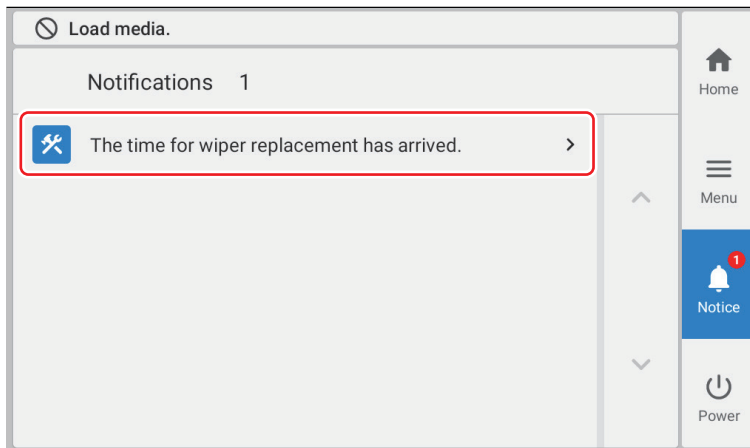

The [Wiper Replacement] screen appears.

5. Tap [Execute].
6. Tap [OK].
The print-head carriage moves to a location where wiper replacement is possible.
7. Follow the instructions on the operation panel to replace the wiper.
 - Tap < or > to check the procedure.
 - If you complete the work without viewing the instructions, tap [Finish All].

IMPORTANT

- Install the wiper so that surface (1) faces to the right.
- After installing the wiper, hold the hooks on the left and right sides, pressing in just enough so that the locks are not released. Then, gently pull the wiper up and check that it is not removed.

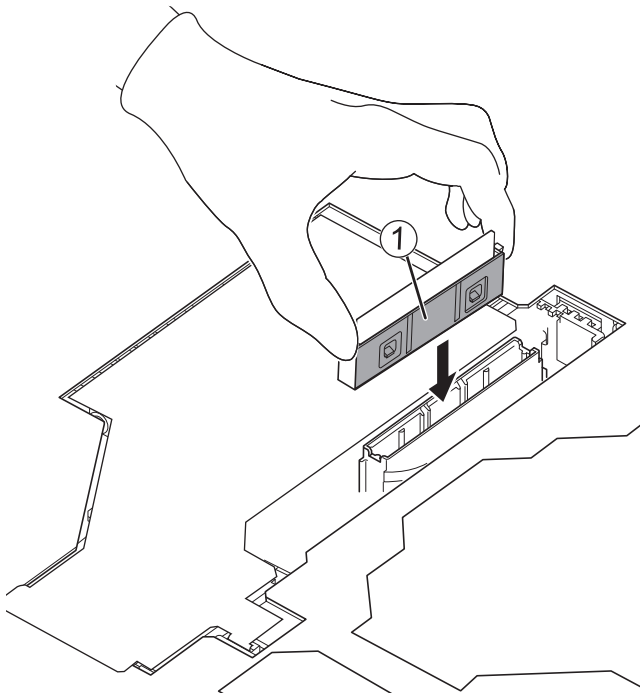

IMPORTANT

- Be sure to use one of the included cleaning sticks.
- Do not use a previously used cleaning stick.
- Do not put a previously used cleaning stick into the cleaning liquid.

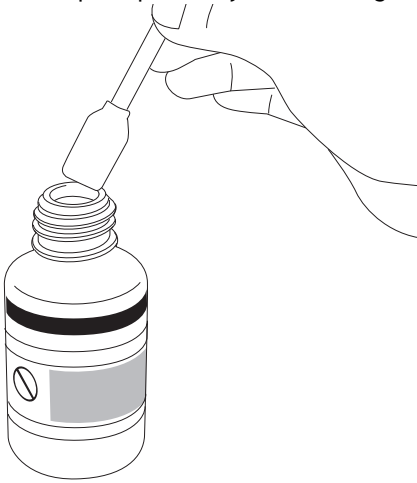

8. When the replacement of the wiper is complete, tap [Finish All].
9. When [Close the cover.] appears, close the right cover.
When you close the right cover, you are returned to the original screen.
10. Tap  to return to the home screen.

Replacing the Wiper Cleaner

The wiper cleaner removes ink, dust, and similar substances that have adhered to the wiper during cleaning.

Replacement is necessary if the [The time for wiper cleaner replacement has arrived.] message appears.

For information about purchasing wiper cleaners, contact your authorized dealer or visit our website (<https://www.rolanddg.co.jp/>).

⚠ WARNING

Be sure to perform operations as specified by the instructions, and never touch any area not specified in the instructions.

Sudden movement of the machine may cause injury or burns.

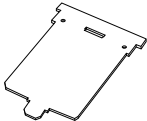
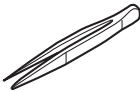
Required items	
	
Wiper cleaner	Tweezers



IMPORTANT

- To prevent the print heads from drying out, finish this procedure in 10 minutes or less. A warning beep sounds after 10 minutes.
- Take care to prevent ink from adhering to the operation panel.

Procedure

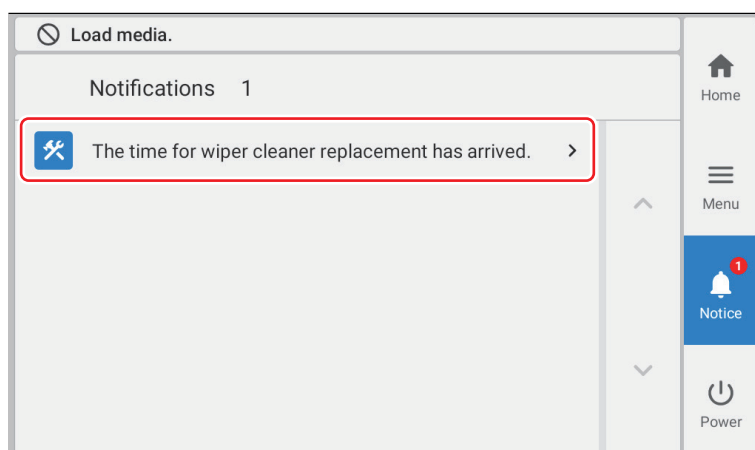
1. When the message [The time for wiper cleaner replacement has arrived.] appears, tap [OK].
2. Remove any media.
3. Tap  to display the messages.
4. Tap [The time for wiper cleaner replacement has arrived.].



-
1. The [Wiper Cleaner Replacement] screen appears.
 2. Tap [Wiper Cleaner Replacement].
 3. Tap [Execute].
 4. Tap [OK].
The print-head carriage moves to a location where wiper cleaner replacement is possible.
 5. Tap [OK].
 6. Tap [OK].
The print-head carriage moves to a location where wiper cleaner replacement is possible.
 7. Follow the instructions on the operation panel to replace the wiper cleaner.
 - Tap  or  to check the procedure.
 - If you complete the work without viewing the instructions, tap [Finish All].
 8. When the wiper cleaner replacement is finished, tap [Finish All].
 9. When [Close the cover.] appears, close the right cover.
When you close the right cover, you are returned to the original screen.
 10. Tap  to return to the home screen.

Replacing the Print Head Caps

The print head caps seal the nozzle surfaces of the print heads, preventing these surfaces from drying out and preventing dust from adhering to them.



Replacement is necessary if the [The time for cap replacement has arrived.] message appears.

For information about purchasing print head caps, contact your authorized dealer or visit our website (<https://www.rolanddg.co.jp/>).

⚠ WARNING

Be sure to perform operations as specified by the instructions, and never touch any area not specified in the instructions.

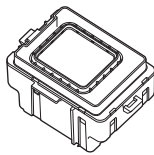
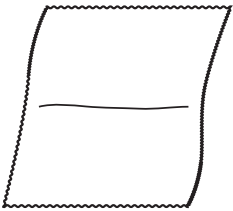
Sudden movement of the machine may cause injury or burns.

Required items		
		
Print head cap	Cloth (that is not fluffy)	Cleaning stick

IMPORTANT

- To prevent the print heads from drying out, finish this procedure in 10 minutes or less. A warning beep sounds after 10 minutes.
- Take care to prevent ink from adhering to the operation panel.

Procedure

1. When the message [The time for cap replacement has arrived.] appears, tap [OK].
2. Remove any media.
3. Tap  to display the messages.
4. Tap [The time for cap replacement has arrived.].





The [Cap Replacement] screen appears.

5. Tap [Execute].

6. Tap [OK].

The print-head carriage moves to a location where print head cap replacement is possible.

7. Follow the instructions on the operation panel to replace the print head caps.

- Tap  or  to check the procedure.
- If you complete the work without viewing the instructions, tap [Finish All].

IMPORTANT

- Ink may drip from the removed print head cap. Exercise caution to prevent this fluid from soiling your hands or the floor.
- To prevent ink from adhering to your hands, the machine, or the floor, cover the bottom surface of the removed print head cap with paper towels or something similar.

8. When the print head cap replacement is finished, tap [Finish All].

9. When [Close the cover.] appears, close the right cover.

When you close the right cover, you are returned to the original screen.

10. Tap  to return to the home screen.

Replacing the Flushing Sponges

The flushing sponge absorbs the discharged ink or cleaning liquid to prevent clogging of the print heads. Replacement is necessary if the [The time for flushing sponge replacement has arrived.] message appears.

IMPORTANT



If the flushing sponge is not replaced after the message appears, the flushing sponge may not sufficiently absorb ink or cleaning liquid, resulting in an overflow.

For information about purchasing flushing sponges, contact your authorized dealer or visit our website (<https://www.rolanddg.co.jp/>).

⚠ WARNING

Be sure to perform operations as specified by the instructions, and never touch any area not specified in the instructions.

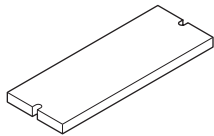
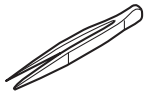
Sudden movement of the machine may cause injury or burns.

Required items			
			
Flushing sponge	Tweezers	Dropper	Cleaning liquid

IMPORTANT

- To prevent the print heads from drying out, finish this procedure in 10 minutes or less. A warning beep sounds after 10 minutes.
- Take care to prevent ink from adhering to the operation panel.

Procedure

1. When the message [The time for flushing sponge replacement has arrived.] appears, tap [OK].
2. Remove any media.
3. Tap  to display the messages.
4. Tap [The time for flushing sponge replacement has arrived.].

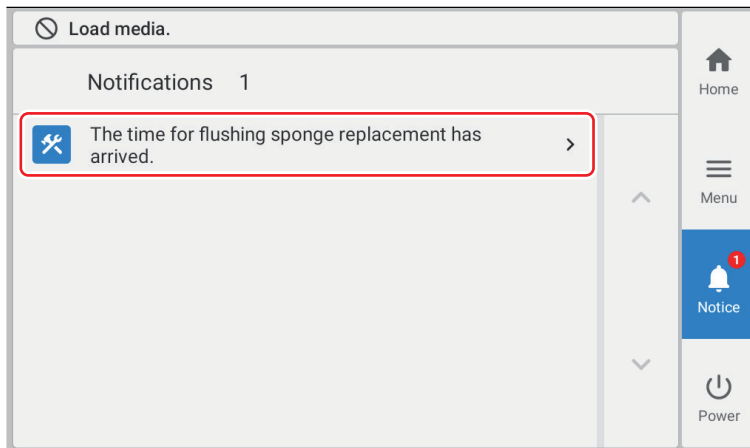

The [Flushing Sponge Replacement] screen appears.

5. Tap [Execute].
6. Tap [OK].
The print-head carriage moves to a location where flushing sponge replacement is possible.
7. Follow the instructions on the operation panel to replace the flushing sponge.
 - Tap < or > to check the procedure.
 - If you complete the work without viewing the instructions, tap [Finish All].

IMPORTANT

Flushing sponges do not have a specified front or back. They can be attached with either orientation.

8. When the flushing sponge replacement is finished, tap [Finish All].
9. When [Close the cover.] is displayed, close the flushing cover.

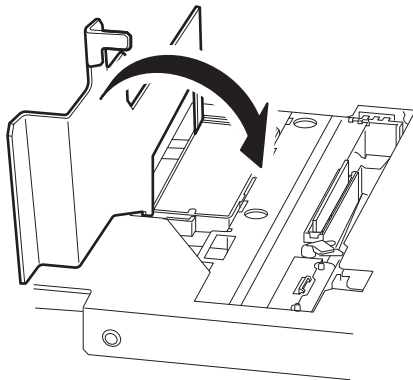

10. Close the right cover.
When you close the right cover, you are returned to the original screen.
11. Tap  to return to the home screen.

Replacing the Blade/Separating Knife

Replacing the Blade

If the blade becomes dull, if the edge of the blade is chipped, or if the cutting quality is lowered, replace the blade with a new blade.

⚠ WARNING

Be sure to perform operations as specified by the instructions, and never touch any area not specified in the instructions.

Sudden movement of the machine may cause injury or burns.

⚠ CAUTION



Never touch the tip of the knife.

Doing so may result in injury. The cutting performance of the blade will also be impaired.

Required item

Replacement blade

1. Replacing the Blade

Procedure

1. Remove any media.
2. Tap .
3. Tap [Maintenance]>[Blade Replacement].
The [Blade Replacement] screen appears.
4. Tap [Execute].
The cutting carriage moves to a position where blade replacement is possible.
5. Follow the instructions on the operation panel to replace the blade.
 - Tap  or  to check the procedure.
 - If you complete the work without viewing the instructions, tap [Finish All].

MEMO

When attaching the blade, orient its tip correctly.

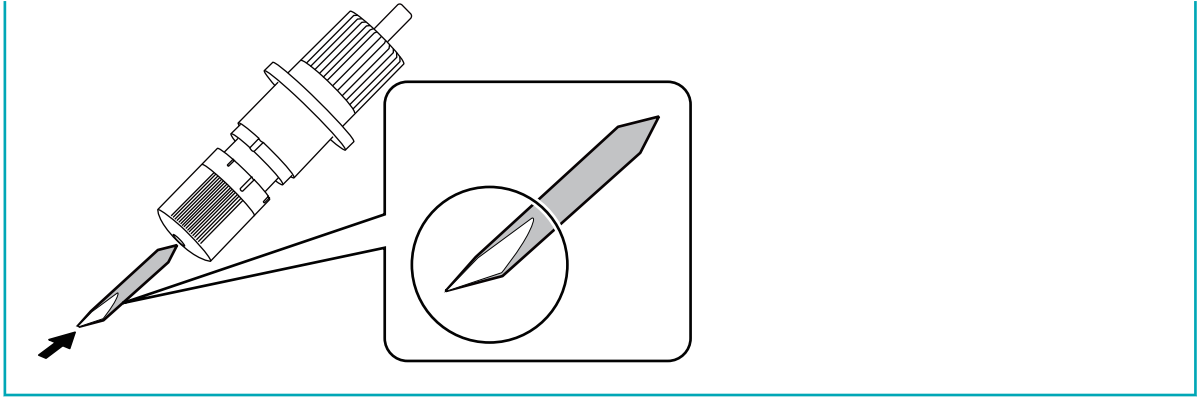

6. When the replacement of the blade is complete, tap [Finish All].
7. When [Close the cover.] appears, close the front cover.
When you close the front cover, you are returned to the original screen.
8. Tap  to return to the home screen.





2. Making Adjustments According to the New Blade

Procedure

1. Set up the media.

2. Tap .

3. Tap [Change] next to [Output Start Location].

4. Tap , , , or  to move the cutting carriage to the location where you want to carry out the cutting test.

You can freely set the location for the cutting test.

5. Tap [Set Base Point Here].

You are returned to the home screen.

6. Tap .

7. Tap [Media Settings]>[Cutting Settings]>[Blade Adjustment].

8. Tap [Execute] next to [Cutting Test].



The test pattern is cut.

9. Check the results of the cutting test.

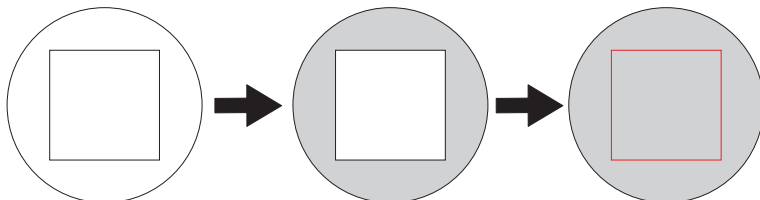
Check that the two shapes are peeled off separately, a blade trace (red line) remains on the backing paper, and the backing paper is not cut.



Check item	Result	Setting item	Adjustment
Check the shape.	The cut shape is distorted.	[Cutting Speed]	Reduce
Peel off the circle.	The square also peels off.	[Blade Force]	Increase
	Some uncut areas remain.	[Cutting Speed]	Reduce
Peel off the square.	The blade leaves faint traces on the backing paper.	[Blade Force]	No change
	The blade trace is indistinct.		Increase
	The blade trace is too deep and cuts into the backing paper.		Reduce

Check item	Result		Setting item	Adjustment
Check the shape of the square you have peeled off.		The corners are not rounded and do not have "horns."	[Blade Offset]	No change
		The corners are rounded.		Increase
		The corners have "horns."		Reduce

10. Tap  or  to change the settings.

Setting item	Setting details	Default setting
[Blade Force]	Set the force (pressure) of the blade.	50 gf (0.11 lbf)
[Cutting Speed]	Set the speed of cutting.	30 cm/s (11.81 in./s)
[Blade Offset]	Set the blade offset. Enter the listed offset value for the blade. The offset value for the included blade is 0.250 mm (9.8 mil).	0.250 mm (9.84 mil)
[Rise Movement Speed]	Set the blade's up speed during cutting (the speed at which the blade travels when it moves to the next cutting line after cutting one cutting line). If the media comes loose during no-load feed and the blade damages the surface of the media, reduce the speed.	30 cm/s (11.81 in./s)

11. Press [Save] to confirm your entry.

12. Repeatedly perform the cutting test and adjust the cutting conditions until the settings are optimized. Repeat steps 8 to 11 to adjust the cutting conditions.

13. Tap  to return to the home screen.

3. Adjusting the Amount of Blade Extension

Adjustment when Not Cutting the Backing Paper (Normal Cut)

When you want to perform accurate and fine adjustment of the cutting-in amount, such as when cutting media with thin backing paper, you can obtain good results by adjusting the amount of blade extension (③). Turn the cap portion of the blade holder to adjust the amount of blade extension. Each indicator tick corresponds to 0.1 millimeters, and adjustment for 0.5 millimeters can be made by rotating the cap one full turn.

Note that making the amount of blade extension too small may cause the tip of the blade holder cap to touch the printed surface, soiling and damaging it. It is important to be especially careful about this when you are using media that has poor ink-adhesion properties.

The amount of blade extension (③) is 0 mm (0 in.) (①) at minimum and 2.5 mm (0.09 in.) (②) at maximum.

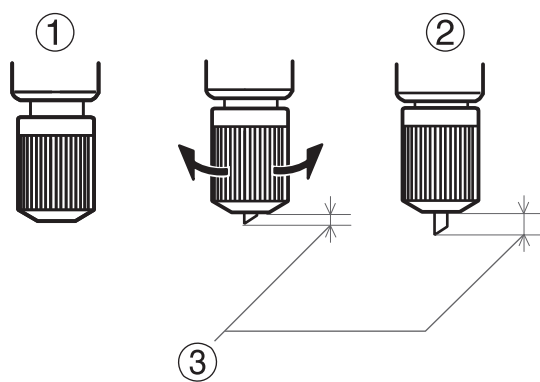

Set the amount of blade extension (①) to an amount that is the sum of the thickness of the media portion (②) and half (④) the thickness of the backing paper (③).

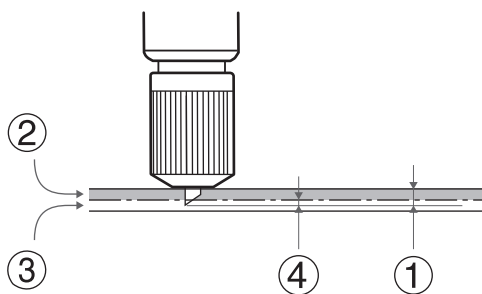

Adjustment when Cutting the Backing Paper (Perforated Cut)

In cases when you want to cut out the printed part, or other cases when you want to cut through the backing paper, use perforated cutting.

IMPORTANT

This function specifies the location to perform perforated cutting in the print data, and performs cutting. This is different from the perforated sheet cutting that cuts to the backing paper at fixed intervals during sheet cutting used when separating the media.

Turn the cap portion of the blade holder to adjust the amount of blade extension. Each indicator tick corresponds to 0.1 mm (3.9 mil), and adjustment for 0.5 mm (19.7 mil) can be made by rotating the cap one full turn.

The amount of blade extension (③) is 0 mm (0 in.) (①) at minimum and 2.5 mm (0.09 in.) (②) at maximum.

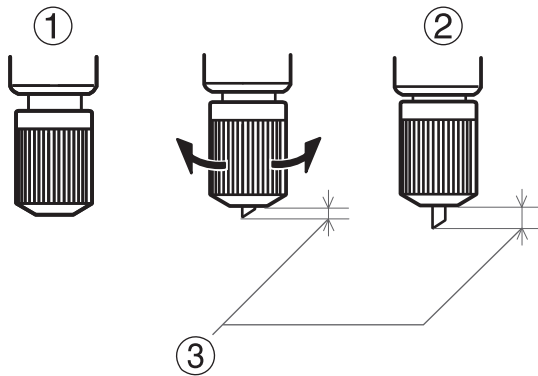

Set the amount of blade extension (③) so that when the cutter pierces the media (④), the blade extends slightly.

For information about the output settings for cutting perforated lines, refer to the documentation for VersaWorks.

<https://downloadcenter.rolanddg.com/VersaWorks7>

IMPORTANT

Pushing the blade out too far will damage the blade and blade protector and hasten their deterioration, so exercise caution.

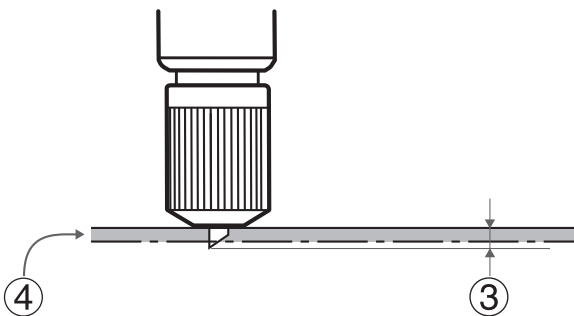

Replacing the Separating Knife

If the separating knife becomes dull, replace it with the included replacement knife.

⚠ WARNING

Be sure to perform operations as specified by the instructions, and never touch any area not specified in the instructions.

Sudden movement of the machine may cause injury or burns.



⚠ CAUTION

Do not touch the tip of the separating knife.

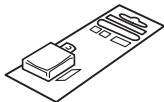
Doing so may result in injury.

Required item

Replacement blade for separating knife

Procedure

1. Remove any media.
2. Tap .
3. Tap [Maintenance]>[Separating Knife Replacement].
The [Separating Knife Replacement] screen appears.
4. Tap [Execute].
The cutting carriage moves to a position where separating knife replacement is possible.
5. Follow the instructions on the operation panel to replace the separating knife.
 - Tap  or  to check the procedure.
 - If you complete the work without viewing the instructions, tap [Finish All].

IMPORTANT

Use the following procedure to remove the separating knife.

1. Loosen the screw until it slips out.
2. Grasp the screw portion, and slowly pull in the direction of the arrow.
When doing this, do not pull it back toward you.

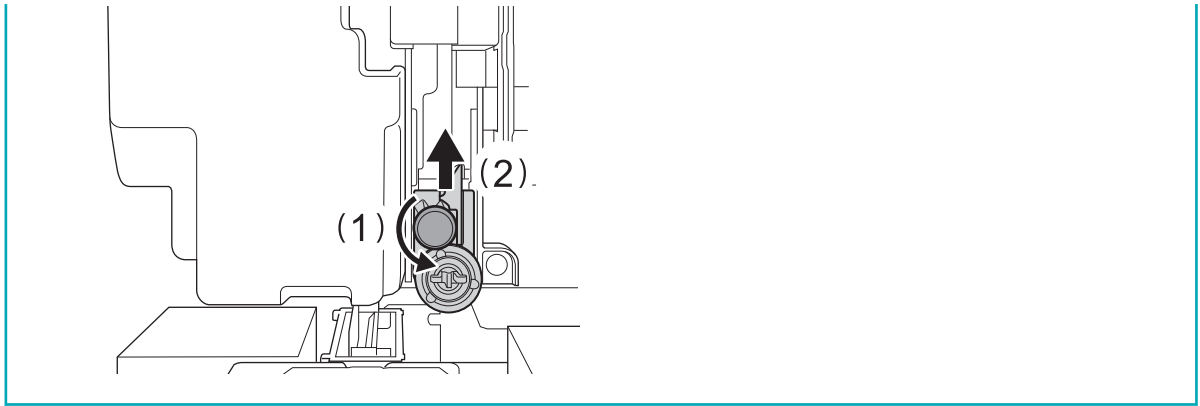

6. When the separating knife replacement is finished, tap [Finish All].
7. When [Close the cover.] appears, close the front cover.
When you close the front cover, you are returned to the original screen.
8. Tap  to return to the home screen.

Inquiries for Consumable Parts and Products

Items That You Can Purchase or Perform by Yourself

To purchase the following consumable parts or products, contact your authorized dealer or visit our website (<https://www.rolanddg.co.jp/>).

Item	Related page
Wiper	P. 337 Replacing the Wiper
Wiper cleaner	P. 340 Replacing the Wiper Cleaner
Print head caps	P. 342 Replacing the Print Head Caps
Flushing sponge	P. 344 Replacing the Flushing Sponges
Cleaning sticks	P. 301 Manual Cleaning Method
Cleaning liquid	
Dropper	
Blade	P. 346 Replacing the Blade
Separating knife	P. 352 Replacing the Separating Knife

Items That Require Inquiries before Replacement

When replacing the following consumable parts, contact your authorized dealer.

Item	Related page
Print heads	P. 300 Cleaning around the Print Heads

Troubleshooting Methods

Output Quality Problems

Printed results are coarse or contain horizontal stripes.....	357
Do the print heads cause dot drop-out?	357
Is the print head height appropriate?	357
Have you carried out [Feed Correction] ?	357
Have you carried out [Media Gap Adjustment] (ink landing position correction)?.....	357
Is the printer installed in a level and stable location?	358
Is the printer installed in a location that is not exposed to direct sunlight?	358
Is the media heating system at a suitable temperature?	358
Is the temperature of the room too low?.....	358
Is the Print Mode Suitable?.....	358
Is the media loaded correctly?	358
Are the [Media Settings] appropriate?	358
The media becomes soiled when printed	360
Do the print heads come into contact with the media?.....	360
Are the print heads dirty?.....	360
Are the pinch rollers or the media clamps dirty?	360
Is the humidity of the room too low?	360
Colors are unstable or uneven.....	361
Did You Shake the Ink Cartridges before Installing Them?	361
Are colors still uneven after mixing the ink by shaking the ink cartridges?.....	361
Is the media wrinkled?	362
Was printing paused partway through?	362
Is the printer installed in a level and stable location?	362
Is the media loaded correctly?	362
Are the Operating Parameters Set to Appropriate Values?	362
Are the [Media Settings] appropriate?	363
Is the printer being used in a location subject to severe changes in the operating environment?	363
Cutting Is Misaligned or Skewed.....	364
Is the media loaded correctly?	364
Are the settings for the cutting conditions appropriate?	364
Is the Cutting Speed in the [Take-up during Cutting] Setting Appropriate?.....	364
Is the length of output too long?.....	364
Are you using media that exhibits large expansion and contraction?	364
Is the setting for the [Cutting Distance Correction] menu item (under [Cutting Settings]) correct?	364
Are the pinch rollers placed on the proper locations?.....	365
Have you corrected the misalignment of printing and cutting?.....	365
Is the blade holder installed appropriately?	365
Is the blade worn?.....	365
Is There Any Buildup of Pieces of Material or Dust Inside the Blade Holder?	365

Printed results are coarse or contain horizontal stripes

Do the print heads cause dot drop-out?

Carry out a printing test and make sure no dot drop-out or dot displacement occurs. If dot drop-out or dot displacement is present, perform cleaning.

RELATED LINKS

- [P. 296 Performing a Printing Test](#)
- [P. 318 Normal Cleaning Method](#)
- [P. 320 When Normal Cleaning Is Not Effective](#)

Is the print head height appropriate?

Printing when the [Print Head Height] menu item is set to [High] or to [Medium] is coarser than when set to [Low]. Keep this set to [Low] except when changing it is necessary, such as when you are using thick media.

RELATED LINKS

- [P. 180 Changing the Print Head Height](#)

Have you carried out [Feed Correction]?

Large misalignment in the amount of feed of the media may result in printing that seems coarse or contains horizontal bands. Either configure the setting in the RIP software to match the type of media you are using, or configure the setting for correction on the printer. When further correction is required, such as when adjustment made using [Simple Correction (Auto)] does not enhance printing, use [Detailed Correction (Manual)] to make the correction.

RELATED LINKS

- [P. 175 Automatically Making Required Adjustments](#)
- [P. 176 Manual Adjustment: Reducing Horizontal Bands \(Feed Correction\)](#)

Have you carried out [Media Gap Adjustment] (ink landing position correction)?

The optimal adjustment varies depending on the height of the print heads and the thickness of the media. Set an adjustment value that is suitable for the media. When further correction is required, such as when adjustment made using [Simple Correction (Auto)] does not enhance printing, use [Detailed Correction (Manual)] to make the correction.

RELATED LINKS

- [P. 175 Automatically Making Required Adjustments](#)
- [P. 178 Manual Adjustment: Adjusting the Misalignment of the Ink Landing Position \(Media Gap Adjustment\)](#)

Is the printer installed in a level and stable location?

Never install the machine in a location where it is tilted or where it may wobble or experience vibration. Also make sure that the print heads are not exposed to moving air. These factors may lead to dot drop-out or reduced printing quality.

Is the printer installed in a location that is not exposed to direct sunlight?

Never install the machine in a location that is exposed to direct sunlight. Doing so may result in dot drop-out or other problems with reduced printing quality, or may even result in malfunction.

Is the media heating system at a suitable temperature?

If the ink forms lumps or smudges, raise the temperature of the media heating system. Note, however, that a temperature that is too high may degrade the media or cause it to wrinkle.

RELATED LINKS

- [P. 190 Setting the Print Heater Temperature](#)
- [P. 192 Setting the Dryer Temperature](#)

Is the temperature of the room too low?

The media heating system may not warm up sufficiently when the ambient temperature is less than 20°C (68°F). Also, even when the media heating system reaches its set temperatures, adequate effectiveness may not be apparent if the media is thoroughly chilled. Before printing, allow the media to come to room temperature.

Is the Print Mode Suitable?

If attractive printing is impossible, try using a higher-quality print mode. Depending on the media, smudging may occur when using a high-quality print mode, and results may also vary greatly depending on the settings of your RIP software (such as the color-profile selection). Select settings appropriate for the media you are using.

Is the media loaded correctly?

If the media is not loaded correctly or the media feed is not smooth, output may be adversely affected. Load the media correctly.

RELATED LINKS

- [P. 33 Setup of New Media](#)
- [P. 77 Setup of Registered Media](#)

Are the [Media Settings] appropriate?

If the settings are not suitable for the type of media, printing may be adversely affected. Choose settings optimized for the media you are using.

RELATED LINKS

- [P. 252 Changing the Media Settings](#)

The media becomes soiled when printed

Do the print heads come into contact with the media?

The height of the print heads may be too low. Also, if the media is not loaded and set up correctly, it may wrinkle or come loose and contact the print heads.

RELATED LINKS

- [P. 180 Changing the Print Head Height](#)
- [P. 33 Setup of New Media](#)
- [P. 77 Setup of Registered Media](#)

Are the print heads dirty?

The following may cause ink to drip on the media during printing.

- Buildup of fibrous dust (lint) around the print heads
- Ink transferred to the print heads due to rubbing against the media

If this happens, perform manual cleaning. We recommend carrying out periodic cleaning of the print heads.

RELATED LINKS

- [P. 300 Cleaning around the Print Heads](#)

Are the pinch rollers or the media clamps dirty?

Periodically clean them.

RELATED LINKS

- [P. 298 Cleaning the Machine](#)

Is the humidity of the room too low?

Use the machine in an environment with a humidity of 35 to 80% RH (no condensation).

Colors are unstable or uneven

Did You Shake the Ink Cartridges before Installing Them?

Shake the ink cartridge 50 times (about 20 seconds), and then reinsert the cartridge. The precipitation of the ingredients in the ink disables printing in normal color. So that the ink mixes well, shake the ink cartridge horizontally with a stroke length of around 5 cm (1.97 in.) from each end of the ink cartridge.

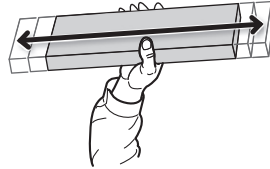

Shake the ink cartridges:

- White ink: Each day (before starting the day's operations).
- Ink other than white ink: When replaced with a new cartridge or when uneven color issues occur

MEMO

To prevent ink precipitation, you can make the machine periodically display a message prompting you to mix the ink.
[P. 275 Showing/Hiding Notifications](#)

IMPORTANT

- **The ingredients in white ink tend to settle.**
Allowing the ink to stand without shaking it can cause the settled material to harden, resulting in malfunction or other problems.
- **Before shaking the ink cartridge, wipe off any ink from around its mouth.**
If you do not wipe off the ink, it may splatter when you shake the ink cartridge.
- **When you have finished mixing the ink, reattach the ink cartridge immediately.**
Taking time to reattach the ink cartridge will adversely affect the ink path.

RELATED LINKS

- [P. 128 Replacing Ink Cartridges](#)

Are colors still uneven after mixing the ink by shaking the ink cartridges?

If colors are still uneven after mixing the ink by shaking the ink cartridges, perform the procedure below.

- White ink
 1. Perform **[Ink Circulation]**.
If the uneven color issue is not corrected after performing **[Ink Circulation]**, perform the following procedure.
 2. Perform **[Light Choke Cleaning]**.
If the uneven color issue is not corrected after performing **[Light Choke Cleaning]**, perform the following procedure.
 3. Perform **[Ink Renewal]**.
 4. If the uneven color issue is not corrected after performing the above work, contact your authorized dealer.
- Ink other than white ink

Colors are unstable or uneven

1. Perform [[Light Choke Cleaning](#)].

If the uneven color issue is not corrected after performing [[Light Choke Cleaning](#)], perform the following procedure.

2. Perform [[Ink Renewal](#)].

3. If the uneven color issue is not corrected after performing the above work, contact your authorized dealer.

RELATED LINKS

- [P. 326 Ink Circulating Method](#)
- [P. 324 Light Choke Cleaning Method](#)
- [P. 327 Ink Renewal Method](#)

Is the media wrinkled?

If the media is wrinkled and comes loose from the platen, colors may be uneven or the printing quality may suffer.

RELATED LINKS

- [P. 33 Setup of New Media](#)
- [P. 77 Setup of Registered Media](#)

Was printing paused partway through?

When printing is paused, the coloring at the seam may be altered when printing resumes. Avoid pausing printing. Before you perform lengthy printing, check the amount of ink remaining. Printing may also pause when data is not sent from the computer quickly enough. We recommend not performing any other tasks with the computer while printing is in progress.

Is the printer installed in a level and stable location?

Never install the machine in a location where it is tilted or where it may wobble or experience vibration. Also make sure that the print heads are not exposed to moving air. These factors may lead to dot drop-out or reduced printing quality.

Is the media loaded correctly?

If the media is not loaded correctly or the media feed is not smooth, output may be adversely affected. Load the media correctly.

RELATED LINKS

- [P. 33 Setup of New Media](#)
- [P. 77 Setup of Registered Media](#)

Are the Operating Parameters Set to Appropriate Values?

Depending on the [[Printing Movement Range](#)] and [[Cleaning during Printing](#)] setting, uneven colors may occur. If the settings have been changed, try restoring them to their default values.

RELATED LINKS

- [P. 262 Speeding Up Output for Narrow Media](#)
- [P. 292 Automatic Maintenance Feature and Notes](#)

Are the [Media Settings] appropriate?

If the settings are not suitable for the type of media, printing may be adversely affected. Choose settings optimized for the media you are using.

RELATED LINKS

- [P. 252 Changing the Media Settings](#)

Is the printer being used in a location subject to severe changes in the operating environment?

Large fluctuations in temperature or humidity while printing is in progress may cause the colors to change partway through the printing. When printing, use the machine in a location where the temperature and humidity are stable.

Cutting Is Misaligned or Skewed

Is the media loaded correctly?

If the media is not loaded correctly or the media feed is not smooth, output may be adversely affected. Load the media correctly.

RELATED LINKS

- [P. 33 Setup of New Media](#)
- [P. 77 Setup of Registered Media](#)

Are the settings for the cutting conditions appropriate?

Misalignment or skewing may occur if the cutting speed is too fast or the blade force is too high. Try changing the cutting conditions. With media having a strong adhesive layer, the adhesive layer reattaches to itself immediately after cutting. However, if a cutting test shows that the peeling of the media and the blade traces on the backing paper are optimal, the media is being cut properly. Be careful not to make the blade force too high.

RELATED LINKS

- [P. 200 Accurately Adjusting the Cutting Settings](#)

Is the Cutting Speed in the [Take-up during Cutting] Setting Appropriate?

If the cutting speed in the [Take-up during Cutting] setting is not appropriate, the media take-up cannot keep up, resulting in partial tension on the media, leading to misalignment or distortion. The media may also stick to the floor and become dirty. Be sure to check the cutting speed.

Is the length of output too long?

For printing followed immediately by cutting in particular, the longer the page length (that is, the longer the distance the media is returned after printing), the greater the chance of misalignment occurring. It is a good idea to keep the size of each single page to the minimum necessary.

Are you using media that exhibits large expansion and contraction?

When you are performing printing followed immediately by cutting, misalignment occurs if the media expands or contracts. If this happens, try performing printing with crop marks followed by cutting. The cutting position will be corrected to match the expansion and contraction of the media.

RELATED LINKS

- [P. 212 Accurately Adjusting the Settings for Cutting with Crop Marks](#)

Is the setting for the [Cutting Distance Correction] menu item (under [Cutting Settings]) correct?

When you are performing printing followed immediately by cutting, go to [Cutting Settings] and set the [Cutting Distance Correction] correction value to 0.00%.

RELATED LINKS

- [P. 204 Performing Distance Correction during Cutting](#)

Are the pinch rollers placed on the proper locations?

Be sure to place the pinch rollers on the grit rollers. If the pinch rollers are not placed on the proper locations, misalignment of the media may occur.

RELATED LINKS

- [P. 33 Setup of New Media](#)
- [P. 77 Setup of Registered Media](#)

Have you corrected the misalignment of printing and cutting?

Misalignment between the printing and cutting positions may occur due to the thickness of the media or the print head height. Make corrections for misaligned printing and cutting for the media you are using.

RELATED LINKS

- [P. 207 Accurately Adjusting the Settings for Printing and Cutting](#)
- [P. 180 Changing the Print Head Height](#)

Is the blade holder installed appropriately?

When installing the blade holder, firmly tighten the screw and check that the blade holder is fixed in place.

RELATED LINKS

- [P. 346 Replacing the Blade](#)

Is the blade worn?

A worn or chipped blade will negatively affect the cutting quality. Check the status of the blade and replace it with a new one if necessary.

RELATED LINKS

- [P. 346 Replacing the Blade](#)

Is There Any Buildup of Pieces of Material or Dust Inside the Blade Holder?

Remove the blade holder, and then take off the cap part of the blade holder and remove any pieces of material or dust inside.

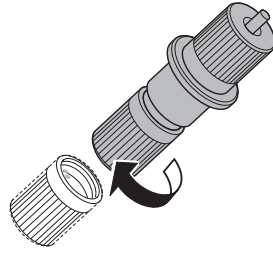

After cleaning, adjust the amount of blade extension.

RELATED LINKS

- [P. 202 Adjusting the Amount of Blade Extension](#)

Problems in Cutting with Crop Marks

Automatic Detection of Crop Marks Fails	368
Are the margins from the pinch rollers to the crop marks too small?	368
Is the media wrinkled or warped?	368
Is the media size too large?.....	368
Are you using media that is likely to reflect light or has deep colors?	368
Are you using transparent media?	368
Printing and Cutting Are Misaligned	369
Have you corrected the misalignment of printing and cutting with crop marks?	369

Automatic Detection of Crop Marks Fails

Are the margins from the pinch rollers to the crop marks too small?

If the margins are too small or the pinch roller locations are not correct, it may not be possible to detect the crop marks. Check the margins and set the pinch rollers in the correct locations.

Is the media wrinkled or warped?

Wrinkled or warped media may cause crop mark detection to fail. Avoid using wrinkled or warped media.

Is the media size too large?

Large media may lead to large errors, which may cause crop mark detection to fail.

When you want to use lengthy media, we recommend performing output with the data separated into sizes that are as short as possible.

Are you using media that is likely to reflect light or has deep colors?

The machine may not be able to read crop marks printed on media that is likely to reflect light or has deep colors.

Procedure

1. Execute [Media Settings]>[Other Media Settings]>[Multi Sensor Adjustment] to correct the sensor for reading crop marks.
2. Tap [Media Settings]>[Cutting Settings]>[Crop Cut Position Adjustment].
3. Select [High] for [Crop Mark Detection Sensitivity].
[Standard] is set by default. When set to [High], [Crop Mark Detection Sensitivity] becomes higher.
If the crop marks still cannot be read, change the media you are using.

RELATED LINKS

- [P. 220 Correcting the Reading Sensor](#)

Are you using transparent media?

The machine cannot read crop marks from transparent media. Change the media you are using.

Printing and Cutting Are Misaligned

Have you corrected the misalignment of printing and cutting with crop marks?

Depending on the composition of the media, the positioning of printing and cutting may be misaligned even when you are using crop marks. Make corrections for misaligned printing and cutting for the media you are using.

RELATED LINKS

- [P. 212 Correcting the Misalignment of Printing and Cutting with Crop Marks \(Concurrent Test for Printing and Cutting with Crop Marks\)](#)
- [P. 215 Correcting the Misalignment of Printing and Cutting with Crop Marks \(Separate Test for Printing and Cutting with Crop Marks\)](#)

Media Feed Problems

Media Wrinkles or Shrinks	371
Is the media loaded and set up straight and securely?	371
Was loaded media allowed to stand for some time?	371
Was the media loaded while the print heater and dryer were hot?	371
Is the temperature of the room too low?	371
Is the humidity of the room too high?	371
Is the media sagging?	371
Are the media heating system temperatures too high?	371
Media Feeding Is Not Straight	372
Is the media loaded and set up straight and securely?	372
Media Feeding Is Not Smooth	373
Is some other object coming into contact with the media?	373
Is the media too thick?	373
Are the grit rollers dirty?	373
A Media Jam Occurs!	374
Is an error message displayed?	374
Is the media warped or wrinkled?	374
Is the height of the print heads too low?	374
Are the grit rollers dirty?	374
Are the media clamps installed?	374
Is the media loaded and set up straight and securely?	374
Is some other object coming into contact with the media?	375
Is the media too thick?	375

Media Wrinkles or Shrinks

Is the media loaded and set up straight and securely?

Feeding is not smooth when the media is not straight or is tensioned unevenly on the left and right. Reload the media.

RELATED LINKS

- [P. 33 Setup of New Media](#)
- [P. 77 Setup of Registered Media](#)

Was loaded media allowed to stand for some time?

Media may wrinkle if it is heated for an extended time. When printing ends, switch off the sub power and remove the media.

Was the media loaded while the print heater and dryer were hot?

Loading media after the print heater and dryer have turned on and warmed up causes the temperature of the media to rise suddenly, which may cause the media to wrinkle during printing. Before loading media, switch off the sub power and allow the platen and apron to cool.

RELATED LINKS

- [P. 188 Adjusting the Ink-drying Method](#)

Is the temperature of the room too low?

The media heating system may not warm up sufficiently when the ambient temperature is less than 20°C (68°F). Also, even when the media heating system reaches its set temperatures, adequate effectiveness may not be apparent if the media is thoroughly chilled. Before printing, allow the media to come to room temperature.

Is the humidity of the room too high?

Use the machine in an environment of 35 to 80%RH (no condensation). High humidity can cause the media to sag. If sagging media is used, it may come out wrinkled.

Is the media sagging?

If sagging media is used, it may come out wrinkled.

Are the media heating system temperatures too high?

Set the temperatures to suitable values for the type of media.

RELATED LINKS

- [P. 188 Adjusting the Ink-drying Method](#)

Media Feeding Is Not Straight

Is the media loaded and set up straight and securely?

Feeding is not smooth when the media is not straight or is tensioned unevenly on the left and right. Reload the media.

RELATED LINKS

- [P. 33 Setup of New Media](#)
- [P. 77 Setup of Registered Media](#)

Media Feeding Is Not Smooth

Is some other object coming into contact with the media?

Make sure the media does not touch anything else. This may affect output, even when the feed appears to be smooth.

RELATED LINKS

- [P. 33 Setup of New Media](#)
- [P. 77 Setup of Registered Media](#)

Is the media too thick?

Media that is too thick may not only cause an unstable feed but may scrape the print heads, resulting in a malfunction. Never use such media.

RELATED LINKS

- [P. 416 Specifications](#)

Are the grit rollers dirty?

Check to make sure the grit rollers are free of buildup of foreign material such as media scraps.

RELATED LINKS

- [P. 298 Cleaning the Machine](#)

A Media Jam Occurs!

Is an error message displayed?

If an error message is displayed because the media has jammed, immediately correct the problem. Doing so may damage the print heads.

RELATED LINKS

- [P. 395 \[Motor Error\]](#)

Is the media warped or wrinkled?

Many factors can cause warping or wrinkling. Refer to the following and correct the problem.

RELATED LINKS

- [P. 371 Media Wrinkles or Shrinks](#)

Is the height of the print heads too low?

Try raising the print heads higher. First, try setting the height to [**Medium**]. If the media is still jammed, change the height to [**High**]. Media may inevitably warp or wrinkle slightly, so adjust the height of the print heads to take this into account.

RELATED LINKS

- [P. 180 Changing the Print Head Height](#)

Are the grit rollers dirty?

Check to make sure the grit rollers are free of buildup of foreign material such as media scraps.

RELATED LINKS

- [P. 298 Cleaning the Machine](#)

Are the media clamps installed?

Install the media clamps when performing printing.

Is the media loaded and set up straight and securely?

Feeding is not smooth when the media is not straight or is tensioned unevenly on the left and right. Reload the media.

RELATED LINKS

- [P. 33 Setup of New Media](#)
- [P. 77 Setup of Registered Media](#)

Is some other object coming into contact with the media?

Make sure the media does not touch anything else. This may affect output, even when the feed appears to be smooth.

RELATED LINKS

- [P. 33 Setup of New Media](#)
- [P. 77 Setup of Registered Media](#)

Is the media too thick?

Media that is too thick may not only cause an unstable feed but may scrape the print heads, resulting in a malfunction. Never use such media.

RELATED LINKS

- [P. 416 Specifications](#)

Machine Problems

The Printer Cannot Be Started Due to Low Temperature.....	377
Setting the Print Heater Temperature at Startup	377
Why Has the Print-Head Carriage Stopped Moving?	378
What to Do First	378
If the Print Heads Still Do Not Move	378
The printer unit does not run.....	380
Is the power switched on?	380
Is [Output possible.] displayed?	380
Are any covers open?	380
Is a message displayed on the screen?	380
Are the cables connected?.....	380
Is the LAN routing appropriate?	380
Are the LAN settings correct?	381
Did the RIP Software End Abnormally?	381
Is an [Ink Cartridge Error] displayed?	381
Is the message [Output is currently paused.] displayed on the screen?	382
The Media Heating System Doesn't Warm Up.....	383
Has the media been set up?	383
Is [Heater Power] turned on?	383
Is the temperature of the room too low?.....	383
Cannot Separate the Media	384
Is the separating knife installed?	384

The Printer Cannot Be Started Due to Low Temperature

Printer startup may not be possible if the internal temperature is low at startup when the sub power is turned on or when the unit returns from sleep mode, and the screen will transition to the [Temperature Too Low to Start] screen.





Warm up the room or otherwise wait until the printer is warm enough to start.

MEMO

Follow the on-screen instructions and configure the [Heater Settings] to accelerate warm-up.

Setting the Print Heater Temperature at Startup

Procedure

1. Tap .
2. Tap [Preferences]>[Standby Heater Temperature].
3. Tap  or  next to [Startup Heater Temperature] to set the temperature.
When this is set to  (off), the media heating system is switched off during startup.
4. Tap [Save] to confirm your entry.
5. Tap  to return to the home screen.

MEMO

- Default setting: 30°C (86°F)

Why Has the Print-Head Carriage Stopped Moving?

If the print-head carriage stops over the platen, take action immediately to prevent the print heads from drying out.

What to Do First

Switch the sub power off and then back on again. If the media is jammed, also remove the media.

If the print-head carriage moves to the home position (inside the right cover), it means the operation has ended successfully.

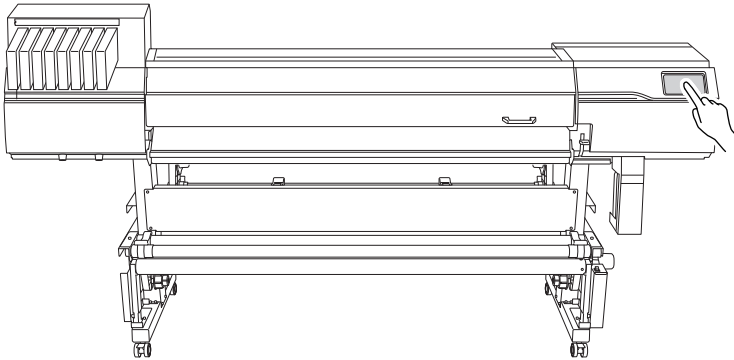

If the print-head carriage still does not move

Switch off the sub power, followed by the main power. Then, switch on the main power again, followed by the sub power.

If the Print Heads Still Do Not Move

If the heads still do not move, carry out the following emergency response measure, and then contact your authorized dealer.

Procedure

1. Switch off the sub power, followed by the main power. Then, open the front cover.
2. Open the right cover.

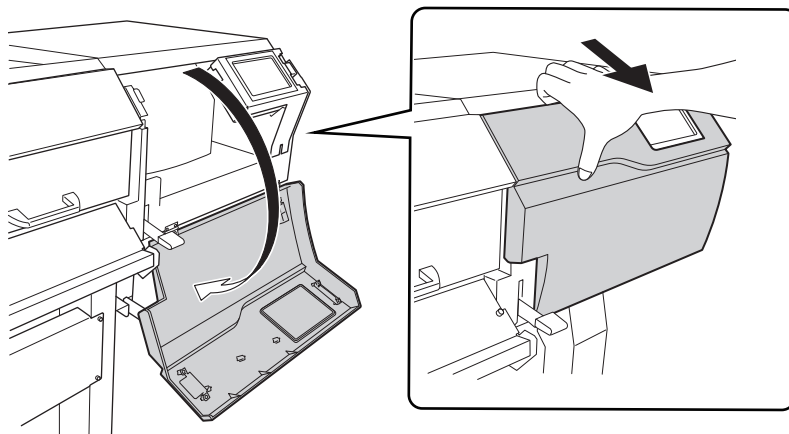

3. Gently move the print-head carriage to the home position by hand.
Stopping at the place where the audible click is heard locks the print-head carriage in place.

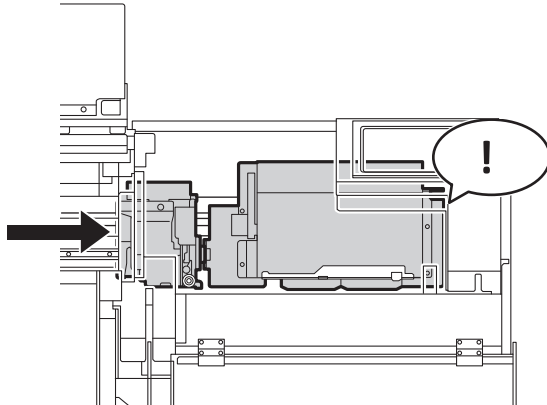

4. Gently apply pressure from the right side to make sure the print-head carriage does not move to the left.
If the print-head carriage moves to the left, move it again slowly by applying pressure from the left side and make sure it locks in place.

The printer unit does not run



Is the power switched on?

Switch on the printer's main power, followed by the sub power and make sure the home screen appears.

RELATED LINKS

- [P. 29 Turning the Power On](#)

Is [Output possible.] displayed?

Output is not performed when [Output possible.] is not displayed in the status bar. After loading the media and lowering the loading lever, tap  [Setup]. Follow the instructions on the screen to finish setting up the media. Also, when operating the setting menu, output doesn't start when data is sent from the computer with some menu items. When you return to a menu item where output is possible or tap  to return to the home screen, output starts.

RELATED LINKS

- [P. 138 Starting Output](#)

Are any covers open?

Close the front, left, and right covers, and the flushing cover.

Is a message displayed on the screen?

Follow the prompts and take action accordingly.

RELATED LINKS

- [P. 387 Messages](#)
- [P. 392 Error Messages](#)

Are the cables connected?

Connect the cables securely.

For details on cable connections, see the "Setup Guide."

RELATED LINKS

- [VG4-640 Setup Guide](#)

Is the LAN routing appropriate?

Check whether or not the network routing is appropriate. Try connecting the computer and the machine to the same hub or connecting them directly using a cable. If this makes it possible to perform output, it means the problem may be in the network itself.

Are the LAN settings correct?

If the cable connections are secure and no problem is found in the network itself, make sure that the IP address and other such settings are appropriate. The settings on both the machine and the computer must be appropriate. Reconfigure the settings, checking to ensure that the IP address does not conflict with the IP address for another device on the network, that the port setting for the RIP software specifies the IP address set on the machine, that the settings have no typing errors, and for other such problems.

For details on the LAN settings, see the "Setup Guide."

RELATED LINKS

- [P. 282 Viewing Network Information](#)
- [VG4-640 Setup Guide](#)

Did the RIP Software End Abnormally?

Make sure the RIP software is running correctly, then switch the sub power off and back on.

RELATED LINKS

- [VersaWorks manual](#)

Is an [Ink Cartridge Error] displayed?

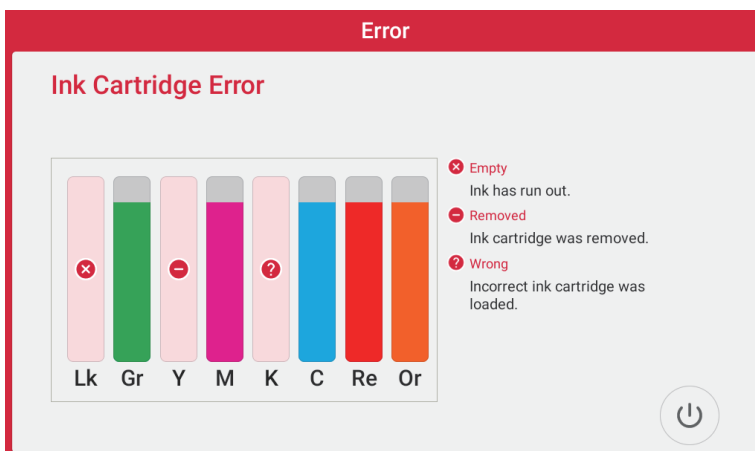

When the screen shown in the figure is displayed, output data cannot be accepted. If there is data that has not yet been output remaining in the machine, output resumes when the error is cleared. If there is unsent data in the computer, output resumes when the data is resent.

When ink runs out

Replace the empty ink cartridge with a new one.

When an ink cartridge with the incorrect color is loaded

Remove the ink cartridge that was loaded incorrectly and load the appropriate ink cartridge.

When an ink cartridge is removed or has not been securely loaded

Securely load the ink cartridge by pushing it all the way to the back.

RELATED LINKS

- [P. 392 \[Ink Cartridge Error\]](#)
- [P. 128 Replacing Ink Cartridges](#)

Is the message [Output is currently paused.] displayed on the screen?

When [Output is currently paused.] is displayed on the screen, operation is paused. To resume, tap [Resume].

RELATED LINKS

- [P. 120 Pausing and Canceling Output](#)

The Media Heating System Doesn't Warm Up

Has the media been set up?

By default, simply switching on the power does not make the media heating system warm up to the preset temperature. Set up the media and wait for the machine to warm up.

RELATED LINKS

- [P. 188 Adjusting the Ink-drying Method](#)

Is [Heater Power] turned on?

If [Cut Only] is selected for [Select Media Output Type] in the media setup, [Heater Power] is set to [Off] and the media heating system does not heat up. Perform setup again with the [Print Only/Print & Cut] output type or set [Heater Power] to [On].

RELATED LINKS

- [P. 33 Setup of New Media](#)
- [P. 77 Setup of Registered Media](#)
- [P. 197 Switching Off the Print Heater and Dryer Together](#)

Is the temperature of the room too low?

The media heating system may not warm up sufficiently when the ambient temperature is less than 20°C (68°F). Also, even when the media heating system reaches its set temperatures, adequate effectiveness may not be apparent if the media is thoroughly chilled. Before printing, allow the media to come to room temperature.

Cannot Separate the Media

Is the separating knife installed?

If the separating knife is not installed, you cannot separate the media.

RELATED LINKS

- [P. 352 Replacing the Separating Knife](#)

Messages on the Operation Panel

Messages	387
[When output, cleaning, and other operations are completed, discard the]	387
[The time for manual cleaning has arrived.]	387
[Maintenance must be performed.Perform manual cleaning.].....	387
[The time for wiper replacement has arrived.]	387
[The time for wiper cleaner replacement has arrived.]	388
[The time for cap replacement has arrived.].....	388
[The time for flushing sponge replacement has arrived.]	388
[Print head protection mode has activated.]	388
[Replace the cleaning liquid pouch.].....	388
[Install the cleaning liquid pouch.]	389
[The extended dryer is not connected.]	389
[The time for ink mixing has arrived.].....	389
[Operation of the take-up unit stopped.]	389
[Place the middle pinch rollers over all the grit rollers.].....	390
[Install the media clamps correctly.]	390
[Media clamps could not be detected.]	390
[The LAN cable is not connected.]	391
[The media could not be detected automatically.Manually set the printing]	391
[Turn on the power. Cleaning will start.].....	391
Error Messages	392
[Ink Cartridge Error]	392
[Cover Open Error]	392
[Media End Error]	392
[Take-up Unit Setup Error]	392
[Pinch Lever Error]	393
[Media Loading Error]	393
[Drain Bottle Error]	393
[Crop Mark Detection Error]	393
[Unable to Fill Wiper Cleaning Liquid]	394
[Pinch Roller Error]	394
[Maintenance Cleaning].....	394
[Print Head Height Mismatch]	395
[Insufficient Media Width]	395
[Printing Size Error]	395
[Motor Error]	395
[Print Head Dry-out Error]	396
[Low Temperature Error]	396
[High Temperature Error].....	396
[Pump Stop Error]	396
[Cleaning Error (Ink Cartridge)]	397
[ConnectHub Communication Error]	397
[Barcode scanning error]	397
[Take-up Unit Communication Error]	397
[Service Call]	398
[Cleaning Error (Drain Bottle)].....	398
[Print Head Error]	398
[Software error]	398
[Communication with Roland DG Connect Hub was not possible.]	398

[Failed to connect to VersaWorks.]	399
[Printing could not start.]	399

Messages

These are the main messages that appear on the machine's operation panel to prompt correct operation. These messages are not errors, so you can close them and perform other work. To check messages again or to carry out their corresponding actions, tap  to display the list of messages. Tap a message to display the menus and procedure required for the action. Perform operations according to the on-screen instructions.

[When output, cleaning, and other operations are completed, discard the]

This message appears when a certain amount of discharged fluid collects in the drain bottle.

Tap [When output, cleaning, and other operations are completed, discard the]>[Execute] to discard this fluid.

RELATED LINKS

- [P. 315 If the Discharged Fluid Disposal Message Appears](#)

[The time for manual cleaning has arrived.]

This message appears when more than 1 week has elapsed since manual cleaning was last performed.

Tap [The time for manual cleaning has arrived.]>[Execute] to perform manual cleaning.

RELATED LINKS

- [P. 301 Manual Cleaning Method](#)

[Maintenance must be performed.Perform manual cleaning.]

This message appears when more than 2 weeks have elapsed since manual cleaning was last performed.

If you do not perform manual cleaning, you will not be able to perform setup of media or any cleaning other than manual cleaning.

Tap [Maintenance must be performed.Perform manual cleaning.]>[Execute] to perform manual cleaning.

RELATED LINKS

- [P. 301 Manual Cleaning Method](#)

[The time for wiper replacement has arrived.]

This message appears when it is time to replace the wiper.

Tap [The time for wiper replacement has arrived.]>[Execute] to replace the wiper.

RELATED LINKS

- [P. 337 Replacing the Wiper](#)

[The time for wiper cleaner replacement has arrived.]

This message appears when it is time to replace the wiper cleaner.

Tap [The time for wiper cleaner replacement has arrived.]>[Execute] to replace the wiper cleaner.

RELATED LINKS

- [P. 340 Replacing the Wiper Cleaner](#)

[The time for cap replacement has arrived.]

This message appears when it is time to replace the print head caps.

Tap [The time for cap replacement has arrived.]>[Execute] to replace the print head caps.

RELATED LINKS

- [P. 342 Replacing the Print Head Caps](#)

[The time for flushing sponge replacement has arrived.]

This message appears when it is time to replace the flushing sponge.

Tap [The time for flushing sponge replacement has arrived.]>[Execute] to replace the flushing sponge.

RELATED LINKS

- [P. 344 Replacing the Flushing Sponges](#)

[Print head protection mode has activated.]

This message appears when the ink in use may not be a product specified by Roland DG Corporation.

If the ink is not a product specified by Roland DG Corporation, a larger amount of ink will be consumed, and drying will be performed frequently. To obtain optimal performance, we recommend that you use ink specified by Roland DG Corporation. To purchase ink, contact your authorized dealer.

[Replace the cleaning liquid pouch.]

This message appears when the cleaning liquid runs out.

Replace the empty cleaning liquid pouch.

After you insert the cleaning cartridge, the cleaning liquid pouch replacement confirmation screen appears.

- If you have replaced the cleaning liquid pouch, tap [Yes]. The amount of cleaning liquid remaining is reset.
- If you have not replaced the cleaning liquid pouch, tap [No]. The amount of cleaning liquid remaining is not changed.

MEMO

If you tap [Yes] on the cleaning liquid pouch replacement confirmation screen even though you have not replaced the cleaning liquid pouch, the amount of cleaning liquid remaining is reset. In this situation, no notification will appear even if the amount of cleaning liquid remaining is very small, and the message [Replace the cleaning liquid pouch.]

will appear when the cleaning liquid runs out. To ensure you have enough time to prepare the replacement cleaning liquid, tap **[No]** if you have not replaced the cleaning liquid.

RELATED LINKS

- [P. 130 Cleaning Liquid Pouch Replacement](#)

[Install the cleaning liquid pouch.]

This is displayed when the cleaning cartridge was removed from the machine, or when a cleaning cartridge that does not contain a cleaning liquid pouch is loaded.

Immediately install a new cleaning liquid pouch or immediately insert the cleaning cartridge.

After you insert the cleaning cartridge, the cleaning liquid pouch replacement confirmation screen appears.

- If you have replaced the cleaning liquid pouch, tap **[Yes]**. The amount of cleaning liquid remaining is reset.
- If you have not replaced the cleaning liquid pouch, tap **[No]**. The amount of cleaning liquid remaining is not changed.

MEMO

If you tap **[Yes]** on the cleaning liquid pouch replacement confirmation screen even though you have not replaced the cleaning liquid pouch, the amount of cleaning liquid remaining is reset. In this situation, no notification will appear even if the amount of cleaning liquid remaining is very small, and the message **[Replace the cleaning liquid pouch.]** will appear when the cleaning liquid runs out. To ensure you have enough time to prepare the replacement cleaning liquid, tap **[No]** if you have not replaced the cleaning liquid.

RELATED LINKS

- [P. 130 Cleaning Liquid Pouch Replacement](#)

[The extended dryer is not connected.]

This message appears when the extended dryer is not connected and **[Preferences]>[Extended Dryer]** is set to **[Enable]**.

Switch the sub power and main power off, and then connect the extended dryer to the printer. When not using the extended dryer, set the extended dryer setting to **[Disable]**.

[The time for ink mixing has arrived.]

This message appears when it is time to mix the ink.

When **[Ink Mixing Notification]** accessed with **[Preferences]>[Notifications On/Off]** is on, this message appears when 24 hours elapse from the last time the ink was mixed.

Tap **[The time for ink mixing has arrived.]** to display the confirmation screen.

Remove just the ink cartridge for the white ink, shake it 50 times (about 20 seconds), and then reinsert this cartridge. On completion, tap **[Yes]**.

[Operation of the take-up unit stopped.]

This message appears and the take-up unit stops when it is not possible to detect the position of the dancer roller for a continuous length of time during media feeding or pull back.

Tap [Operation of the take-up unit stopped.] and follow the instructions on the screen to recover the take-up unit.

[Place the middle pinch rollers over all the grit rollers.]

This message appears when the middle pinch rollers have not been properly placed. Position these pinch rollers properly between the left and right pinch rollers.

RELATED LINKS

- [P. 33 Setup of New Media](#)
- [P. 77 Setup of Registered Media](#)

[Install the media clamps correctly.]

This message appears when the media clamps are not placed at the predetermined positions. Check the loading status of the media and that the pinch rollers have been positioned correctly, and then correctly set the media clamps at the ends of the media.

RELATED LINKS

- [P. 33 Setup of New Media](#)
- [P. 77 Setup of Registered Media](#)

[Media clamps could not be detected.]

This message appears when the media clamps cannot be detected because they are hidden by the media.

Check the loading status of the media and that the pinch rollers have been positioned correctly, and then correctly set the media clamps at the ends of the media.

This message appears when the media clamps cannot be detected because their parts that are read are dirty with, for example, ink.

Use cleaning liquid and a cleaning stick to clean the white parts on the media clamps.

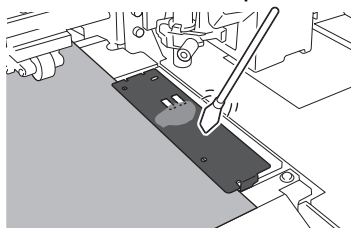

It may not be possible to detect the media clamps because the multi sensor is dirty with ink due to reasons such as the media striking it immediately after printing.

Install the media clamps correctly and clean their parts that are read. If this message still appears, contact your authorized dealer.

RELATED LINKS

- [P. 33 Setup of New Media](#)
- [P. 77 Setup of Registered Media](#)

[The LAN cable is not connected.]

This message appears when the machine and a computer are not connected with a LAN cable. Properly connect the LAN cable.

[The media could not be detected automatically. Manually set the printing]

This message appears when media with high reflectance is set up. Manually set the printing area.

When setting up new media: Refer to Step 8 in [3. Registering the Media\(P. 51\)](#).

When setting up media that is already registered: Refer to Step 6 in [3. Select the media.\(P. 95\)](#).

[Turn on the power. Cleaning will start.]

This message appears when the following situations occur 24 hours or more after the previous cleaning.

- An ink cartridge is empty or an ink cartridge has not been inserted.
- The message **[Discard the discharged fluid in the bottle.]** appears.

Check the ink cartridges or dispose of discharged fluid, and then switch on the sub power.

RELATED LINKS

- [P. 128 Replacing Ink Cartridges](#)
- [P. 313 Disposing of Discharged Fluid](#)

Error Messages

This section describes the error messages that may appear on the machine's operation panel and how to take action to remedy the problem.

Follow the instructions on the screen to clear the error or switch the power off before starting to operate the machine again.

If the action displayed on the screen does not correct the problem or if an error message not described here appears, contact your authorized dealer.





[Ink Cartridge Error]

This message appears when one of the following ink cartridge errors is detected.

MEMO

When an error occurs, the , , or  icon is displayed next to the corresponding ink cartridge on the screen.

Implement appropriate countermeasures according to the error.

- **When ink runs out**
 -  **[Empty]** [Ink has run out.]
Install the new ink cartridge.
- **When an ink cartridge is removed**
 -  **[Removed]** [Ink cartridge was removed.]
Load the removed ink cartridge.
- **When an ink cartridge of an incorrect color or incorrect type is loaded**
 -  **[Wrong]** [Incorrect ink cartridge was loaded.]
Remove the incorrectly loaded ink cartridge, and then load the correct ink cartridge.
When an ink cartridge is removed,  **[Ink cartridge was removed.]** is displayed.

[Cover Open Error]

The front, left, or right cover, or the flushing cover, is open.

For safety, some carriage operations are limited while a cover is open. Close the front, left, and right covers, and the flushing cover.

[Media End Error]

This is displayed if the amount of remaining media is insufficient when feeding media during printing output.

Switch to new media, and then send the data again.

[Take-up Unit Setup Error]

This is displayed if the amount of remaining media is insufficient during setup of the take-up unit.

Replace with new media and perform setup again.

[Pinch Lever Error]

The loading lever was raised during media setup or after completing this setup.
Lower the loading lever and redo setup.

[Media Loading Error]

This message appears when [Media Edge Detection] is set to [Enable] and media has not been fed with the pinch rollers set incorrectly.

Raise the loading lever, set the pinch rollers correctly, and then set up the media again.

This message appears when [Media Edge Detection] is set to [Enable] and the media is too short.

The media is not long enough to be detected. Raise the loading lever, set [Media Edge Detection] to [Disable], and then set up the media again.

For the setup method when [Media Edge Detection] is set to [Disable], refer to 1. B: Determining the Positions of Media (If [Media Edge Detection]: [Disable])(P. 66).

RELATED LINKS

- [P. 33 Setup of New Media](#)
- [P. 77 Setup of Registered Media](#)

[Drain Bottle Error]

[Discard the discharged fluid in the drain bottle.]

This message appears when the drain bottle has reached its limit for discharged fluid.

Discard the discharged fluid in the drain bottle, and then attach this bottle again.

MEMO

When the drain bottle is detached, the error message changes to [Install the drain bottle.].

[Install the drain bottle.]

This message appears when the drain bottle is misaligned.

Re-install the drain bottle.

[Crop Mark Detection Error]

[Crop marks could not be detected.]

Automatic detection of crop marks could not be accomplished.

The machine may not be able to read crop marks printed on media that is likely to reflect light or has deep colors. Perform the following operations.

Procedure

1. Execute [Media Settings]>[Other Media Settings]>[Multi Sensor Adjustment] to correct the sensor for reading crop marks.
2. Tap [Media Settings]>[Cutting Settings]>[Crop Cut Position Adjustment].

3. Select [High] for [Crop Mark Detection Sensitivity].

[Standard] is set by default. When set to [High], [Crop Mark Detection Sensitivity] becomes higher.

If the crop marks still cannot be read, change the media you are using.

[Crop marks were detected however the size or position was incorrect.]

Automatic detection of crop marks could not be accomplished.

Load the media at the correct position and perform detection of crop marks again. If repeating automatic crop-mark detection also results in an error, start over again from the printing of crop marks.

RELATED LINKS

- [P. 33 Setup of New Media](#)
- [P. 77 Setup of Registered Media](#)
- [P. 157 How to Cut with Crop Marks](#)
- [P. 220 Correcting the Reading Sensor](#)
- [P. 368 Are you using media that is likely to reflect light or has deep colors?](#)

[Unable to Fill Wiper Cleaning Liquid]

[Replace the cleaning liquid pouch.]

The cleaning liquid pouch ran out while supplying this liquid for cleaning or to the wiper tray.

Quickly replace this cleaning liquid pouch with a new one.

[Install the cleaning liquid pouch.]

Install the cleaning liquid pouch into the cleaning cartridge, and insert the cleaning cartridge into the slot.

[Pinch Roller Error]

The left (right) pinch roller is positioned at a location where it cannot pinch the media.

Raise the loading lever and move the pinch roller to the correct location.

RELATED LINKS

- [P. 33 Setup of New Media](#)
- [P. 77 Setup of Registered Media](#)

[Maintenance Cleaning]

This message appears when more than 2 weeks have elapsed since manual cleaning was last performed.

Media setup cannot be completed if manual cleaning is not performed.

Perform manual cleaning.

RELATED LINKS

- [P. 301 Manual Cleaning Method](#)

[Print Head Height Mismatch]

The set print head height and the actual print head height are different.

Follow the instructions on the screen to change the print head height. When you change this height, [OK] is displayed on the screen. Tap [OK] to resume printing.

If 10 minutes elapse after the print-head carriage moves, the print heads are capped and the data is canceled to prevent the heads from drying out.

RELATED LINKS

- [P. 180 Changing the Print Head Height](#)

[Insufficient Media Width]

[The print data is larger than the media width.Continue output?]

This message appears when the size of the printing data is larger than the printing area of the loaded media.

To continue performing output without making corrections, tap [Continue Output]. At this time, the portion extending beyond the printing area is not output.

To cancel output, tap [Cancel]. Make the printing area wider, for example, by replacing the media with a larger piece of media, and then send the data again.

MEMO

There is no limitation on the size of the data in the media-feed (FEED) direction.

[Printing Size Error]

[Crop marks cannot be added.Continue output]

This message appears when one of the following situations is detected.

- **The size of the data with crop marks is larger than the printing area of the loaded media.**
To continue performing output without making corrections, tap [Continue Output]. The data is output without printing the crop marks.
To cancel output, tap [Cancel]. Make the printing area wider, for example, by replacing the media with a larger piece of media, and then send the data again.
- **The width of the printing data is less than 60 mm (2.36 in.).**
Make the horizontal-direction (scan-direction) size of the data at least 60 mm (2.37 in.). To continue performing output without making corrections, tap [Continue Output]. At this time, the data is output without printing the crop marks.
To cancel output, tap [Cancel]. Increase the size of the data, and then send the data again.

MEMO

There is no limitation on the size of the data in the media-feed (FEED) direction.

[Motor Error]

A motor error occurred.

Operation cannot be continued. Turn off the sub power. Next, eliminate the cause of the error, then immediately switch on the sub power.

If the machine is allowed to stand with the error uncorrected, the print heads may dry out and become damaged. This error may be caused by such factors as a mistake in loading the media, a media jam, or an operation that pulls the media with excessive force.

The media has jammed.

Carefully remove the jammed media. The print heads may also be damaged. Perform cleaning, and then perform a printing test and check the results.

Has the media been pulled with excessive force?

Excessive tension was applied to the media, and additional action is necessary to recover from this state. First, raise the loading lever and adjust the media to create a small amount of slack, and then switch on the sub power.

[Print Head Dry-out Error]

This message appears when the print heads are forced to the home position to prevent them from drying out.

Operation cannot be continued. Switch the sub power off, and then back on.

[Low Temperature Error]

The internal temperature of the machine has fallen below the ambient temperature at which it can operate.

Operation cannot be continued. Turn off the sub power.

The displayed temperature is the current temperature inside the machine. Bring the installed location to a temperature at which operation is possible (20°C to 32°C [68°F to 89.6°F]), allow the machine to come to room temperature, and then turn on the power.

RELATED LINKS

- [P. 29 Power Supply Operations](#)

[High Temperature Error]

The internal temperature of the machine has risen above the ambient temperature at which it can operate.

Operation cannot be continued. Turn off the sub power.

The displayed temperature is the current temperature inside the machine. Bring the installed location to a temperature at which operation is possible (20°C to 32°C [68°F to 89.6°F]), allow the machine to come to room temperature, and then turn on the power.

RELATED LINKS

- [P. 29 Power Supply Operations](#)

[Pump Stop Error]

This message appears when an ink cartridge is pulled out during pump operation, such as during cleaning, and is left in this state for 10 minutes or more.

Operation cannot be continued. Insert the removed ink cartridge. Switch the sub power off, and then back on.

[Cleaning Error (Ink Cartridge)]

The printer made an emergency stop for one of the following reasons.

- A cartridge was pulled out during the initial ink filling.
- An ink cartridge was pulled out or became empty during [Light Choke Cleaning].

Operation cannot be continued. Perform the following operations.

1. Check that the ink cartridges are inserted and that there is sufficient ink. Replace any empty ink cartridges.
2. Switch the sub power off and back on.
3. Perform [Light Choke Cleaning] or fill the machine with ink.

MEMO

If the printer stopped partway through [Light Choke Cleaning], perform [Ink Renewal], and then perform [Light Choke Cleaning] again.

RELATED LINKS

- [P. 324 Light Choke Cleaning Method](#)
- [P. 327 Ink Renewal Method](#)

[ConnectHub Communication Error]

This is displayed when the remaining media management function is used and any of the following has occurred.

- Roland DG Connect Hub has not been launched on the computer.
- This machine is not registered in Roland DG Connect Hub.
- Roland DG Connect Hub cannot communicate with the outside.
- A subscription for Roland DG Connect has not been made.

Eliminate the cause of the error, and then tap [OK].

[Barcode scanning error]

This is displayed when correct barcode reading failed when acquiring the remaining media without using the take-up unit during roll media setup.

Reload the media correctly, and then tap [OK].

RELATED LINKS

- [P. 33 Setup of New Media](#)
- [P. 77 Setup of Registered Media](#)

[Take-up Unit Communication Error]

This message appears when an error such as the connection being lost during take-up unit setup occurs.

Operation cannot be continued. Switch off the sub power, followed by the main power. Check that the take-up unit is properly connected, and then once more switch on the main power, followed by the sub power.

[Service Call]

An unrecoverable error occurred or part replacement that must be performed by a service technician is required.

After turning the power off, contact your authorized dealer.

[Cleaning Error (Drain Bottle)]

This message appears when one of the following situations is detected.

- The drain bottle was removed or became full while [Light Choke Cleaning] was in progress.
- The drain bottle was removed or became full during initial ink filling.

Operation cannot be continued. Perform the following operations.

1. Discard the discharged fluid in the drain bottle, and then attach this bottle again.
2. Check that the ink cartridges are inserted and that there is sufficient ink.
3. Switch the sub power off and back on.
4. Perform [Light Choke Cleaning].

MEMO

If the printer stopped partway through [Light Choke Cleaning], perform [Ink Renewal], and then perform [Light Choke Cleaning] again.

RELATED LINKS

- [P. 324 Light Choke Cleaning Method](#)
- [P. 327 Ink Renewal Method](#)

[Print Head Error]

This is displayed when an unusable print head is installed.

After turning the power off, contact your authorized dealer.

[Software error]

An error occurred in the internal communication or applications of the machine or part replacement that must be performed by a service technician is required.

Switch off the sub power and then the main power. Then, switch on the main power again, followed by the sub power. If the error still occurs, contact your authorized dealer.

[Communication with Roland DG Connect Hub was not possible.]

[Try again later.]

This message is displayed when Roland DG Connect Hub cannot establish an external connection.

Tap [OK] and try again later.

[Check the status of the connection between Roland DG Connect Hub and VersaWorks.]

This message is displayed when connecting to Roland DG Connect Hub or VersaWorks fails.
Verify that Roland DG Connect Hub and VersaWorks are running.

[Failed to connect to VersaWorks.]

[Restart VersaWorks.]

This message is displayed when connecting to VersaWorks fails.
Restart VersaWorks and tap [OK].

[Printing could not start.]

[Check the status of VersaWorks. (One possibility is that the job could not be found.)]

This message is displayed when no job that has been set to [Print] in VersaWorks is found.
Check the jobs set to [Print] in VersaWorks.

[Check the status of VersaWorks. (Two possibilities are that printing is already in progress and that the setup area has been exceeded.)]

This message is displayed when printing is already in progress or when the print data is larger than the printing area.
Check to see if printing is in progress or if the print data is larger than the printing area.

Appendix

Operations When Moving the Unit

Preparing to Move the Machine.....	402
Step 1: Removing Media and the Blade Holder	402
Step 2: Circulating the Ink (Only When Using White Ink)	404
Step 3: Discarding the Discharged Fluid	405
Step 4: Securing the Print-head Carriage in Place Using the Retainer	407
Step 5: Reinstalling the Machine	409

Preparing to Move the Machine

Before moving the machine, dispose of the discharged fluid and secure the print-head carriage in place. Attempting to move the machine without proper preparation may result in damage to the print heads or damage to internal components due to leaking ink.

IMPORTANT

- Once the preparations for moving the machine are complete, move the machine promptly and turn on the machine as soon as possible after the machine is relocated. If you leave the machine alone without turning it on, the precipitated ink will coagulate and result in problems such as the clogging of the print heads.
- When moving the machine, keep it at a temperature from 5 to 40°C (41 to 104°F) and at a humidity from 20 to 80% RH (with no condensation). Failure to do so may result in a breakdown.
- Handle the machine with care when moving it, keeping it level (not tilted at an angle) and preventing it from striking other objects.

Step 1: Removing Media and the Blade Holder

MEMO

The procedure for replacing the blade is displayed on the operation panel, but this section only describes the work for removing the blade.

Procedure

1. Remove any media.

MEMO

If no media is loaded, raise the loading lever.

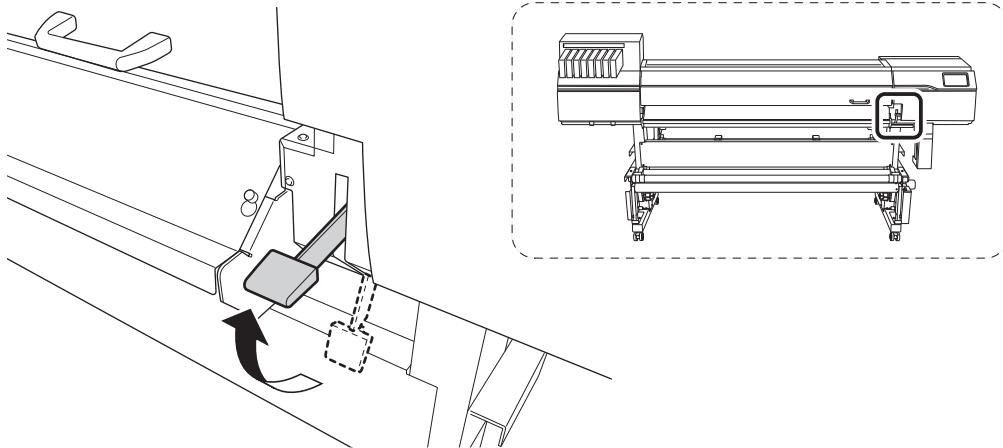

2. Tap .

3. Tap [Maintenance]>[Blade Replacement].
The [Blade Replacement] screen appears.

4. Tap [Execute].
The cutting carriage moves to a position where blade replacement is possible.

5. When [Open the front cover.] appears, open the front cover.
6. Detach the blade holder.
7. Tighten the screw.
8. Tap [Finish All].
9. Close the front cover.

Step 2: Circulating the Ink (Only When Using White Ink)

* This operation is not required for the ink types shown below. Proceed to [Step 3: Discarding the Discharged Fluid\(P. 405\)](#).

- Eight colors (cyan, magenta, yellow, black, light black, green, orange, and red)
- Eight colors (cyan, magenta, yellow, black, light cyan, light magenta, orange, and red)
- Four colors (cyan, magenta, yellow, and black)

Procedure

1. Tap .
2. Tap [Maintenance]>[Ink Circulation].
The [Ink Circulation] screen appears.
3. Tap [Execute].
Ink circulation starts.

Step 3: Discarding the Discharged Fluid

Procedure

1. Tap .
2. Tap [Maintenance]>[Drain Bottle].
3. Tap [Execute].
4. Tap [OK].
5. Remove the drain bottle and discard the discharged fluid.



IMPORTANT

When you remove the drain bottle, a few drops of discharged fluid may come out of the machine. Exercise caution to prevent this fluid from soiling your hands or the floor.

⚠ WARNING

Never place discharged fluid or ink near an open flame.
Doing so may cause a fire.

⚠ CAUTION

To store discharged fluid temporarily, place it in the included drain bottle or in a durable sealed container such as a metal can or polyethylene tank, and cap the container tightly.
Any spillage or vapor leakage may cause fire, odor, or physical distress.

IMPORTANT

Dispose of discharged fluid properly, in accordance with the laws in effect in your locale. Discharged fluid is flammable and contains toxic ingredients. Never attempt to incinerate discharged fluid or discard it with ordinary trash. Also, do not dispose of it in sewer systems, rivers, or streams. Doing so may have an adverse impact on the environment.

6. Quickly attach the emptied drain bottle to the machine once more.
7. Tap [Finish].

8. Turn off the sub power followed by the main power.

Step 4: Securing the Print-head Carriage in Place Using the Retainer**Procedure**

1. Open the left cover.

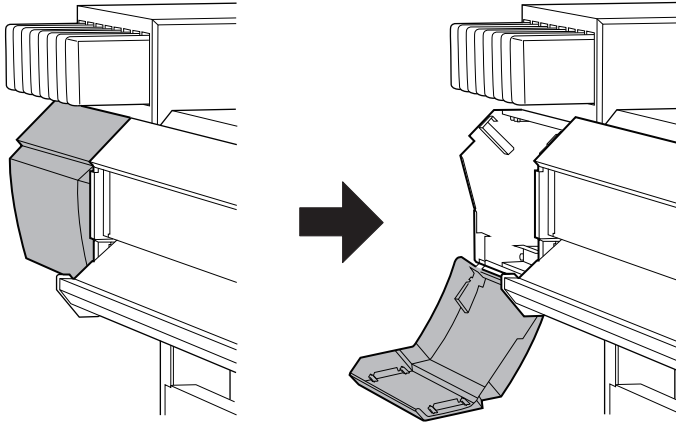

2. Remove retainer C.

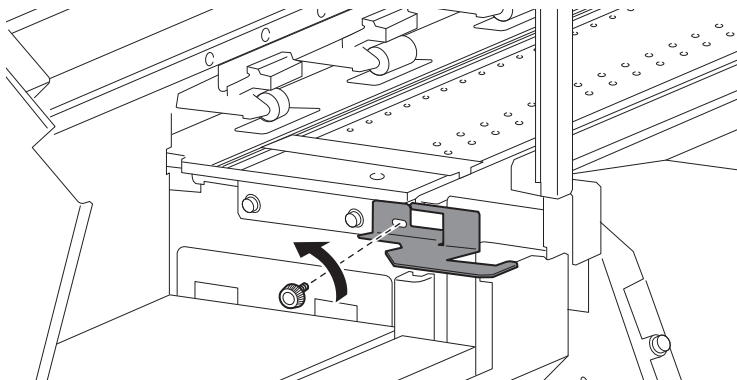

3. Open the front cover.

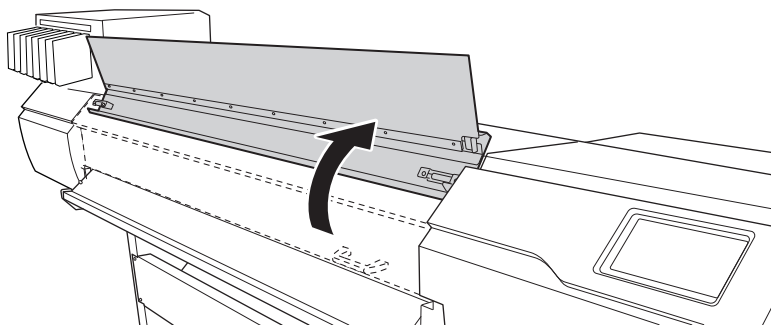

4. Hook the removed retainer C into hole A, then fasten with a screw at the position shown in the figure to fasten the cutting carriage in place.

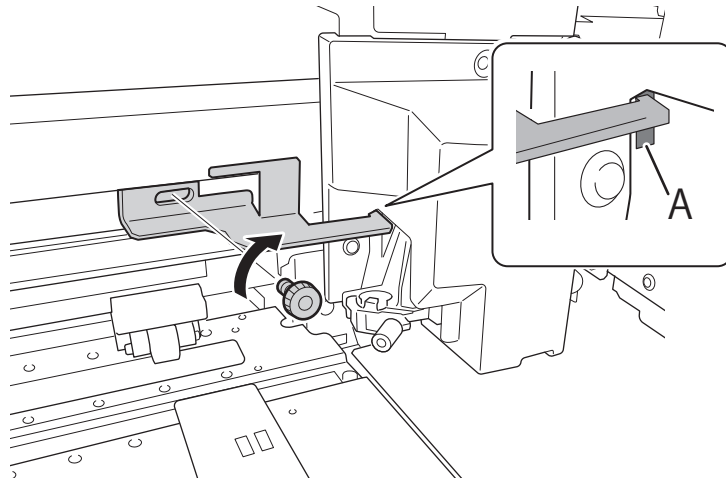

5. Close the front and left covers.

Step 5: Reinstalling the Machine

Procedure

1. Once the preparations are complete, move the machine with as little delay as possible.
2. Immediately reinstall the machine, and then open the front cover.

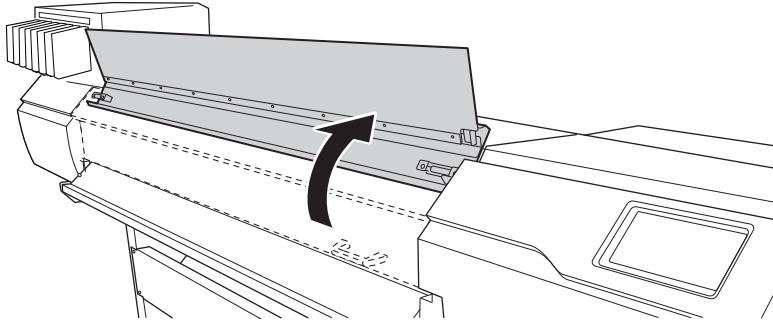

3. Remove retainer C that was fastening the cutting carriage.

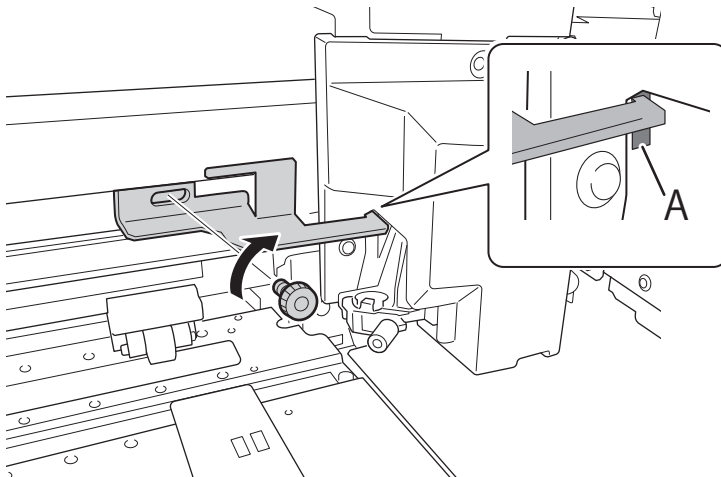

4. Open the left cover.

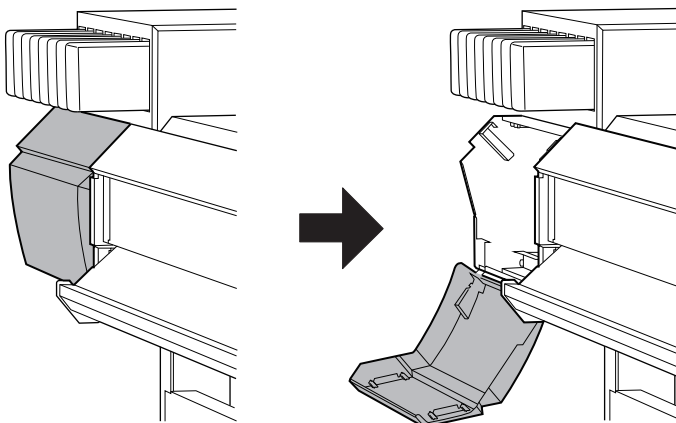

5. Install retainer C at the position indicated in the figure for storage.

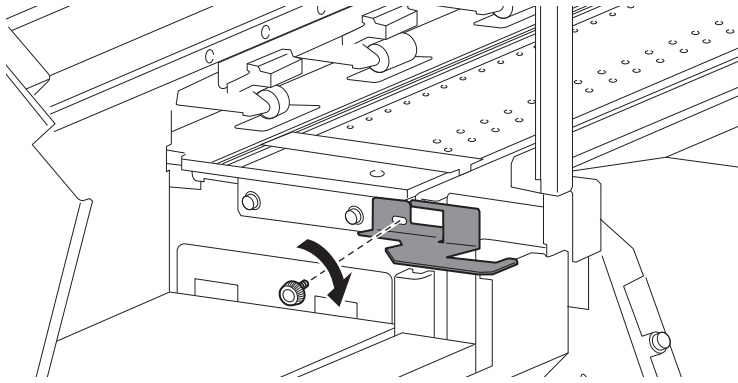

6. Close the front and left covers.

7. Turn on the main power switch.

IMPORTANT

To prevent the print heads from being damaged, move the machine with as little delay as possible and switch on the main power as soon as possible after moving the machine. To install the machine again, follow the procedure in the Setup Guide.

8. Press the sub power button.

The home screen appears.

MEMO

If the initial setup or the ink filling is not complete, the language selection screen will appear. Follow the instructions on the screen to carry out the initial setup and ink filling.

Main Specifications

- Printing/Cutting Area 412
 - Maximum Area 412
 - Maximum Printing Area When Using Crop Marks..... 413
 - Media Separation Location during Continuous Printing..... 414
 - About the Blade 415
- Specifications 416

Printing/Cutting Area

Maximum Area

The printing or cutting area along the horizontal plane of the loaded media (the direction in which the print-head carriage moves) is determined by the positions of the pinch rollers.

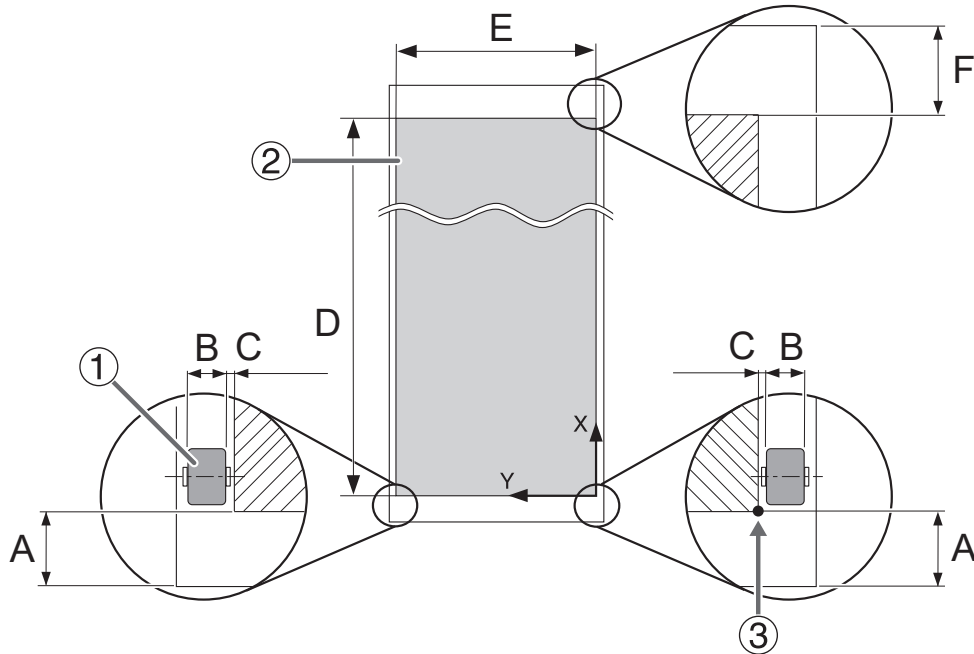

①	Pinch roller
②	Printing or cutting area
③	Printing or cutting coordinates origin (0,0)
A	75 mm (3 in.)
B	10 mm (0.4 in.)
C	1.5 mm (0.06 in.)
D	Max. 24,998 mm (984.2 in.)
E	64-inch model: Max. 1,600 mm (63 in.), 54-inch model:Max. 1,346 mm (53 in.)
F	99 mm (3.9 in.)

Maximum Printing Area When Using Crop Marks

The maximum printing area when crop marks are used is reduced from the maximum printing area when crop marks are not used by an amount equal to the crop marks.

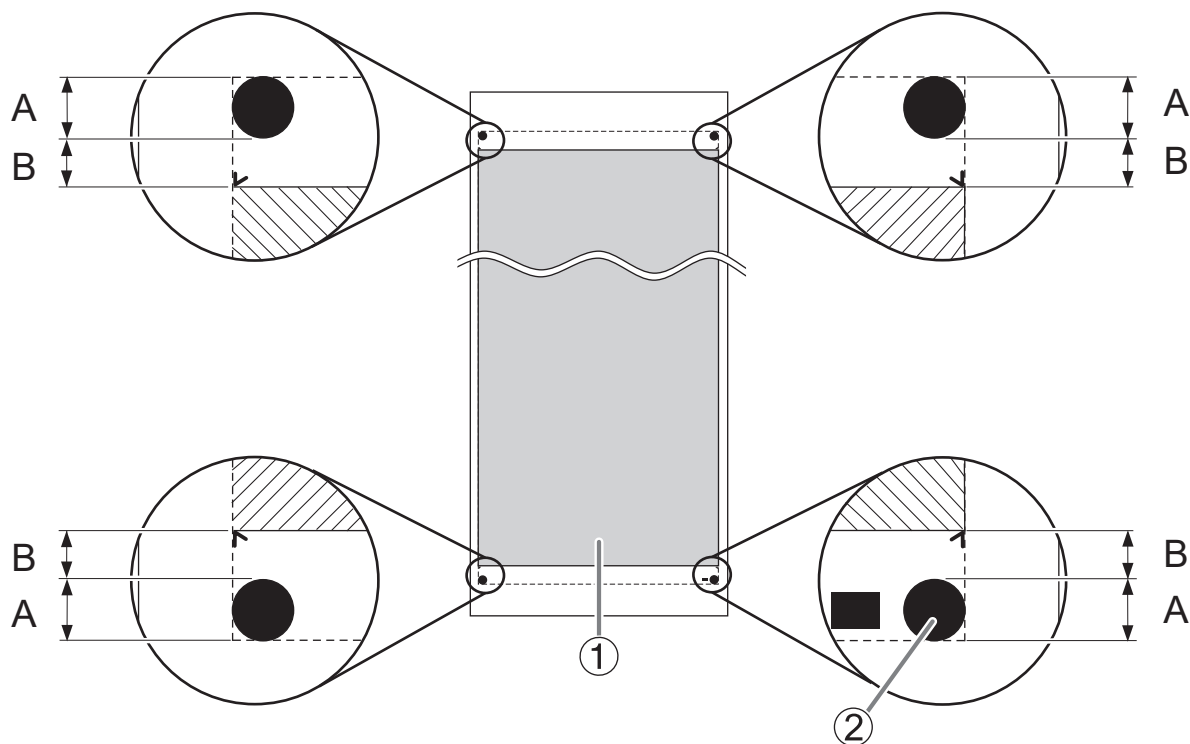

①	Printing or cutting area
②	Crop mark
A	12.5 mm (0.5 in.)
B	10 mm (0.4 in.)

Media Separation Location during Continuous Printing

When a command for separating the media is sent from the computer, the separation location on the media is as shown in the figure below.

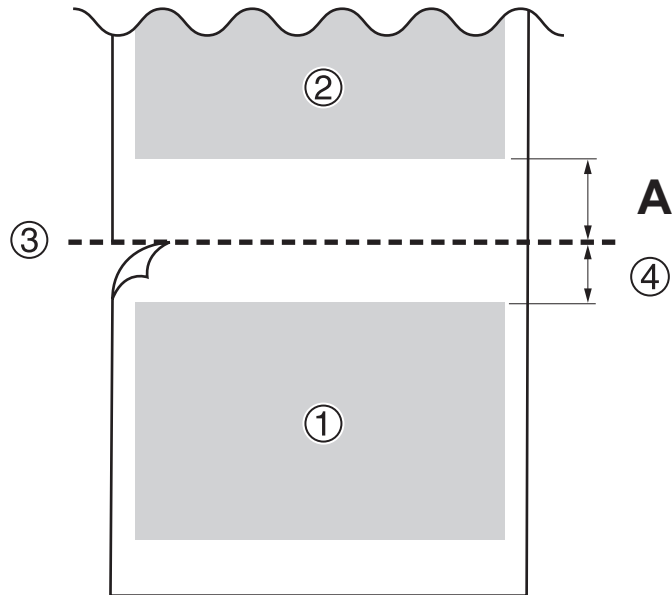

①	First page
②	Second page
③	Separation location
④	Margin (RIP software value)
A	35 to 75 mm (1.38 to 2.95 in.) (Default value: 75 mm (2.95 in.))

About the Blade

The cutting conditions and the service life of the blade change according to the media and the operating environment, even when you're using identical blades. The service life also differs according to the type of blade. A rough guide is shown below.

Blade	Media	Blade force	Amount of blade offset (amount of blade tip correction)	Blade life (general guide)*1
ZEC-U5032	General Signage Vinyl	30 to 100 gf	0.25 mm (0.01 in.)	8,000 mm (26,246.7 ft.)
ZEC-U5025	General Signage Vinyl	30 to 100 gf	0.25 mm (0.01 in.)	4,000 mm (13,123.4 ft.)
	Fluorescent Vinyl	120 to 200 gf	0.25 mm (0.01 in.)	4,000 mm (13,123.4 ft.)
	Fluorescent Vinyl	100 to 200 gf	0.25 mm (0.01 in.)	4,000 mm (13,123.4 ft.)

*1 The values for "Blade life" are estimates for when an identical type of media is used.

When uncut areas remain even when the blade force is increased to a value that is higher than the values shown in this chart by 50 to 60 gf, replace the blade.

Specifications

		VG4-640	VG4-540
Printing method		Piezo ink-jet method	
Media	Width	335 to 1,625 mm (13.2 to 64 in.)	295 to 1,371 mm (11.7 to 54 in.)
	Thickness	Maximum 1.0 mm (39.3 mil) with liner, for printing Maximum 0.4 mm (15.7 mil) with liner and 0.22 mm (8.6 mil) without liner, for cutting	
	Roll outer diameter	Max. 250 mm (9.84 in.)	
	Roll weight	Max. 45 kg (99 lb.)	Max. 35 kg (77 lb.)
	Core diameter	76.2 mm (3 in.) or 50.8 mm (2 in.)	
Printing/cutting width*1		Max. 1,600 mm (62.9 in.)	Max. 1,346 mm (52.9 in.)
Ink	Type	Eco-Solvent Ink (TR3) 500 ml cartridge (white only 220 ml)	
	Colors	Eight colors (cyan, magenta, yellow, black, light black, green, orange, and red) Eight colors (cyan, magenta, yellow, black, light cyan, light magenta, orange, and red) Seven colors (cyan, magenta, yellow, black, orange, red, and white [×2]) Four colors (cyan [×2], magenta [×2], yellow [×2], and black [×2])	
Printing resolution		Max. 1,800 dpi	
Cutting speed		10 to 300 mm/s (0.39 to 11.8 in./s)	
Blade force*2		30 to 500 gf	
Blade	Type	Roland CAMM-1 series compatible	
	Offset	0.000 to 1.500 mm (0.0 to 59 mil)	
Software resolution (when cutting)		0.025 mm/step (0.98 mil/step)	
Media heating system*3		Print heater set temperature: 30 to 45 °C (86 to 113 °F) Dryer set temperature: 30 to 55 °C (86 to 131 °F)	
Connectivity		Ethernet (100BASE-TX/1000BASE-T, automatic switching)	
Power-saving function		Automatic sleep feature	
Rated input		100-120/220-240 VAC, 50/60 Hz, 8.6/4.4 A	
Power consumption	During operation	Approx. 1,140 W	
	Sleep mode	Approx. 40 W	
Acoustic noise level	During operation	66 dB (A) or less	
	During standby	56 dB (A) or less	
Dimensions (width × depth × height)		2,886 mm (113.62 in.) × 748 mm (29.45 in.) × 1,415 mm (55.71 in.)	2,632 mm (103.62 in.) × 748 mm (29.45 in.) × 1,415 mm (55.71 in.)
Weight		189 kg (417 lb.)	182 kg (402 lb.)
Environment	During operation	Temperature: 20 to 32 °C (68 to 89.6 °F), humidity: 35 to 80%RH (no condensation)	
	Not operating	Temperature: 5 to 40 °C (41 to 104 °F), humidity: 20 to 80%RH (no condensation)	
Included items		Dedicated stand, power cord, media take-up unit, media holders, replacement blade for separating knife, cleaning liquid bottle for maintenance, drain bottle, User's Manual, software (VersaWorks, Roland DG Connect Hub), etc.	

*1 The length of printing or cutting is subject to the limitations of the application software.

*2 • 500 gf is the maximum instantaneous blade force.

• The blade force must be adjusted according to details such as the media thickness.

*3 • Warm-up is required after power up. This may require 5 to 20 minutes, depending on the operating environment.

• Depending on the ambient temperature and the media width, the set temperature may not be reached.

Memo

Software 418

Software

This product is equipped with an "eT-Kernel Multi-Core Edition" eT-Kernel and a "PrCONNECT(R)/Pro" TCP/IP protocol stack, both made by eSOL Co., Ltd. eT-Kernel and PrCONNECT are registered trademarks of eSOL Co., Ltd.

Company names and product names are trademarks or registered trademarks of their respective holders.

